

The best in chain technology



Continuous innovation – of the highest quality!



Our innovation strategy

We set the new technological standards.

One of the defining elements of our business strategy and vision is leading the field in technological innovation.

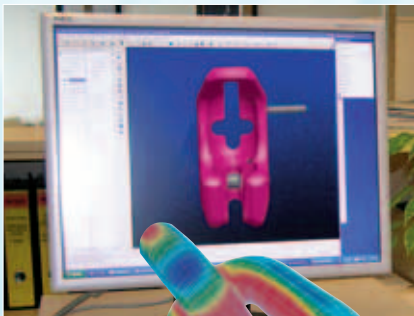

Certified as the first chain manufacturer with integrated quality and environmental management system according to ISO 9001/14001.

The success story of > pink < goes on!

The r(évolution) in chain steel (patented), combined with special design and production processes (ICE-hardened) enables the quantum leap to a new class of its own.



- RUD production ■ and sales units ■ worldwide.
- All our products have in common: advanced technology and highest quality.
- RUD is always a pioneer in decisive product developments.
- Currently we have nearly 500 German and International patents and trade marks.

1953	As the first chain manufacturer, RUD receives the inspection stamping H1 for high tensile chains	
1967	Approval of Grade 50	
1972	Approval of Grade 80	
1994	Approval of Grade 100	
2006	Approval of Grade 100 acc. to PAS 1061* <small>*PAS = Publicity Available Specification</small>	
2007	Approval of Grade 120	



I	= Innovative
C	= Chain
E	= Evolution

The r(évolution) in chain steel (patented) and in the production process (ICE-hardened) enables the quantum leap to a new "class of its own".



The fool proof assembly system ICE Grade 120

	<p>Advantages of the assembly system ICE Grade 120 4 – 7</p>
	<p>RUD-ID-System® 8 – 9</p>
	<p>Technical data and ICE WLL charts 10 – 11</p>
	<p>ICE-System: fool proof combination variety 12 – 13</p>
	<p>ICE Masterlinks with fool proof clevis connection 14 – 15</p> <ul style="list-style-type: none"> ● ICE Standard-masterlinks ● ICE Special-masterlinks
	<p>ICE Connection and Shortening elements 16 – 21</p> <ul style="list-style-type: none"> ● ICE-Connection link ● ICE-Shortening hook ● ICE-H-Connector ● ICE-Multishortening claw ● ICE-Precise length adjuster ● ICE-Balancer
	<p>ICE-End fittings 22 – 24</p> <ul style="list-style-type: none"> ● ICE-Star-hook ● ICE-Automatic-clevis hook ● ICE-Foundry hook
	<p>ICE-Dumper accessories 24 – 25</p> <ul style="list-style-type: none"> ● ICE-Dump truck suspension link ● ICE-Dump truck automatic clevis hook
	<p>ICE-Spare parts 24 – 25</p>
	<p>Overview ICE-Lashing chains ICE-CURT 26 – 29</p>
	<p>WLL overview chart ICE-120, VIP-100 and Grade 80 30 – 31</p>
	<p>Overview Lifting points 32 – 35</p>



RUD – the first chain manufacturer with approval of Grade 120 – many ideas ahead!



RUD has received from the responsible employer's insurance association (BG Metall Nord Süd) as first chain manufacturer the permittance stamp "D" for round steel link chains in the **quality grade 120**.

The BG Metal and surface treatment Technical Committee have tested and issued – Test certificate PZNM.

Every ICE chain and component will be marked with the new stamp D1 – 12.



RUD is officially approved by Germanischer Lloyd (meanwhile firming under the name DNV GL) as manufacturer of studless chains and chain

accessories for Lifting, Lashing and Towing in accordance with GL Rules for Metallic Materials (Certificate WZ 1218 HH 3).



Insensitive to hydrogen embrittlement.

Stress crack corrosion – the resistance is according to PAS 1061.



The high quality ICE-chains and components get a special ICE-Pink-Powder Coating (colour: traffic purple).

Due to the double coating system (pre-treatment and ICE-Pink-Powder Coating) there is a considerably better surface protection than with an oiled or galvanized finished chain.

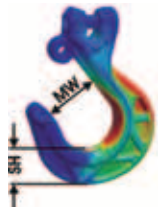

Due to FEM-supported design construction optimising, up to 25 % less weight than the next larger hook in Grade 80 with the same throat opening and base thickness.

Grade	80	120
Chain Ø	13	10
WLL/kg	5000	5000
Throat opening/mm	40	40
Base thickness/mm	37	37
Weight/kg	2.5	1.7

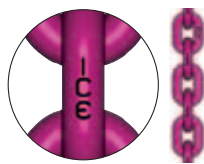

Fool-proof:

- Every link is stamped with ICE on the reverse side
- Every component is clearly marked with ICE

● Colour: ICE-Pink → traffic purple

● **Clear distinction** compared with VIP-Magenta-Pink Grade 100 and Grade 80 Red

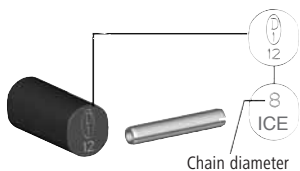

The successful and often copied RUD clevis system will continue with ICE-Grade 120. Due to its dimensioning and colour coding, there is a fool-proof connection with the right chain diameter.

ICE- Load pin – oval shaped – cannot be combined with other RUD-Grades!
Fool-proof!



Ice Masterlinks are equipped with an allside flexible weld-in clevis connection.

The masterlink is completed with an X-shaped (stands for ISO Grade 120) with an integrated, patented chain gauge.

This leads to a fool-proof connection in regard of the chain diameter and number of legs.



Testing and documentation of chain slings and components becomes quite easy with the **RFID-technology** (Radio Frequency IDentification).

See instructions at page 8 and 9

The decisive ICE-advantages – always one diameter thinner than Grade 80!

Chain diameter mm	WLL in kg	
	Grade 80	ICE
6	–	1800
8	2000	3000
10	3150	5000
13	5300	8000
16	8000	12500
20	12500	–

Due to the enormous high durability of the patented ICE-material, we are able, for the first time, to continuously utilise a chain diameter smaller compared with Grade 80 on diameters ≤ 16 mm. This means that, no matter which diameter, whether lifting of lashing, an ICE lifting or lashing chain is able to replace a Grade 80 chain of the next larger size.

The reduction in weight of more than 30 % is a considerable factor in work ergonomics.

Reduction of weight = extremely light construction

- Clearly less material
- Less energy used
- Easier handling due to light construction

Reduction of weight...

...of more than 30 %!

- Environmentally-friendly
- Health and safety advantages because of lighter construction

Comparison: single leg chain sling terminating in a sling hook H1-V, EWL = 3000

RUD – ICE 120

RUD – Grade 80
DIN EN 818-4

WLL	8 t	8 t
Chain diameter	13 mm	16 mm
Component	IAK-RG-13 + IMVK-13	AK 1-16 + BSEK
	ICE-Chain 13 x 39	Chain 16 x 48 Grade 80
	Length 3.000 mm	Length 3.000 mm
	ICE-STAR-Hook 13	GSH 16
Weight	20.5 kg = 100 %	27.0 kg = 130 %

Quality class 12 – Grade 120 – Breaking strength = 1200 N/mm²



Despite ICE having a considerably higher breaking strength = 1200 N/mm² compared with Quality grade 80 – 800 N/mm² the elongation at break remains the same!

The elongation at break is guaranteed with $\geq 25\%$ in natural black condition. When pink powder coated, the elongation is $\geq 20\%$.



Dynamic test results guarantee at least 20000 load cycles with ICE in 50 % over load!

In permanent operation, e.g. in connection with hoist devices and cranes with high dynamic applications > 20000 load cycles, the WLL must be determined according to EN 818-7 Mechanism group 1 Bm (M3), a mean stress of 160 N/mm² that means, for example, a larger chain diameter.

ICE → up to 60 % higher Breaking Force/WLL than Grade 80!

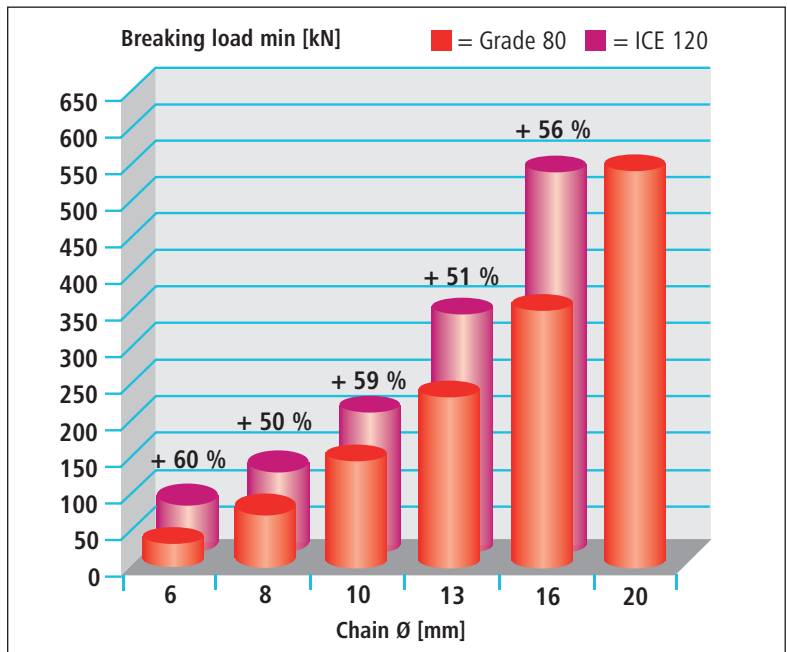
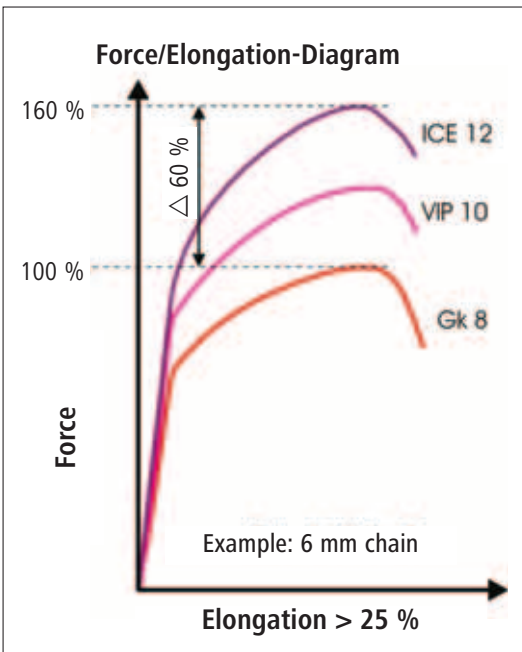

Considerably improved toughness and impact value > 55 J at -60°C!!!

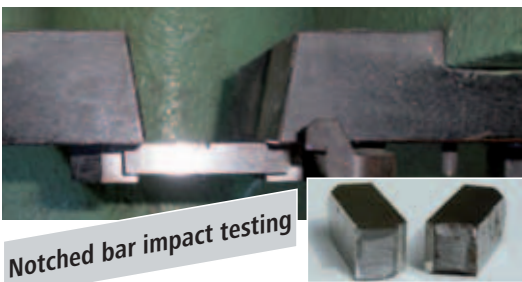

With an impact test, it can be shown if the chain has enough toughness when it is exposed to severe conditions. Compared with a chain Grade 80 = 40 J at -20°C, the RUD-ICE-Chain has => 55 J at -60°C. This is a very important property when there are extreme demands!

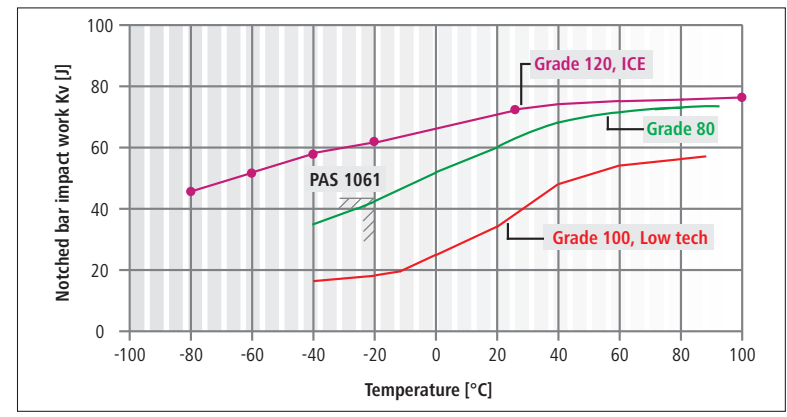

Temperature

Hot or cold –
ICE is the best!

Ideal for Polar and
Arctic use;
Extremely tempera-
ture resistant
-60°C up to +300°C
Resistance to brittle
fracture < -70°C.

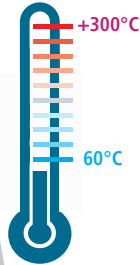
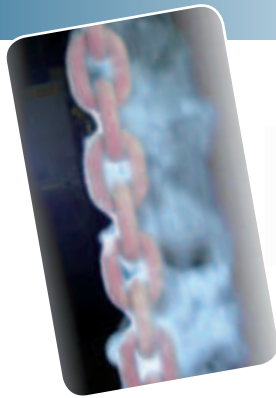

Overheating indicator EP 677681 (European Patent)

The special ICE-Pink-Powder Coating shows the effects of temperature in which the chain can be safely used. It is prohibited to use the ICE-Pink chain in temperatures of more than 300°C. This is clearly displayed by ICE-Pink colour turning brown-black.

The ICE-Chains must be taken out of service or send them back to the manufacturer for maintenance!

Most economical due to special hardness!



When it's sharp
edged and rough



No matter whether it's hot or cold, when the usage is extreme, especially material handling at ports or usage at construction sites etc., the patented material and the special RUD-ICE hardening provides advantages to the user.

Damages on the chain caused by sharp edges will be reduced compared to chain with lower hardness due to the increased strength.

Longer life due to special heat treatment and patented material



- higher abrasion toughness
- more insensitive towards sharp edges
- Due to 30 % better surface hardness than Grade 80 clearly longer endurance
- ICE = 460 HV

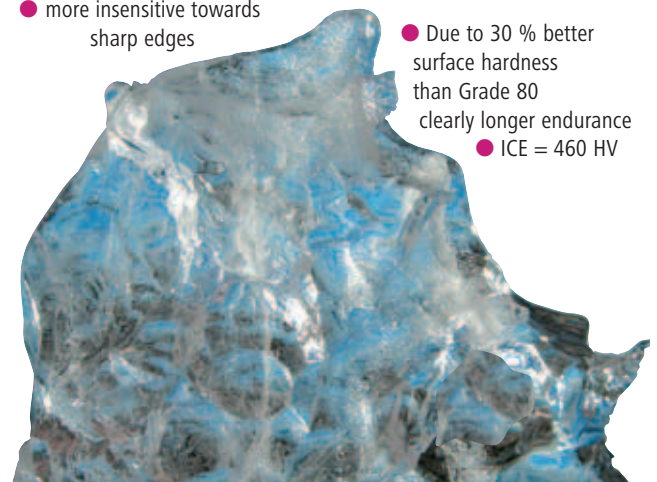

RUD ID System®

Inspection and documentation made easy!



Regular inspections of lifting applications are an essential requirement to ensure the highest standard of safety is met. Dated methods of inspections involve copious amounts of paper work and time consuming manual processes.

But due to the **RFID-technology** (Radio-Frequency-Identification) these time consuming methods and huge amount of paper work become history.

RFID technology has been specifically designed to track and identify applications quickly and effortlessly making inspections and documentation of products a quick and easy process.

Radio Frequency Identification (RFID) continues to evolve as a major technology – modernizing the way documentation and inventory mangement is done



RUD ID System®



RUD-ID-POINT®

The **RUD-ID-POINT®** (RFID chip) is embedded into the component. The RFID chip is branded with a unique identification number.

Size comparison:



RUD-ID-READER

The robust RUD reading devices capture the identification number of the **RUD-ID-POINT®** and transfer it to the **RUD-ID-NET®** application (software) or alternatively to your PC applications (e.g. WordPad, MS Word, MS Excel, SAP) etc.



RUD-ID-NET®

The resourceful **RUD-ID-NET®** application (software) will support your product administration and documentation.



RUD ID System[®]

RUD-ID-Points[®]



Reference no.:
7902580



Reference no.:
7998881



Reference no.:
7903680



Reference no.:
7901001

The innovative and unrivalled **RUD-ID-POINT[®]** performs in varied conditions ranging from -80°C temperatures to an astonishing +270°C. They hold a high level of water and pollution resistance and are extremely robust against damage. The RFID-chip does not harm the capability of the components.

RUD-ID-POINT[®] 8 mm or 4 mm (13.56 MHz HF):

Press-fit transponder (in metal). No glue necessary.

Size: 8 mm x 3.25 mm or 4 mm x 3.50 mm.

The usage of **RFID-Chips** embedded into a component is a patented technological innovation.

RUD-ID-LINK (13.56 MHz HF)

Connecting link with integrated transponder for chains, wire ropes, etc.

Size: dia. 8 mm x 35 mm open

RUD-ID-GLUE[®] (13.56 MHz HF)

Adhesive metal transponder for many other working means, subject to regular checking (clamps, grippers, cross bars, etc)

Size: dia. 19 mm x 4.5 mm

Additional colors and design on request.

RUD-ID-READER



Reference no.: 7903364



Reference no.: 7901524 (Bluetooth)

The **RUD-ID-EASY-CHECK[®]** readers are compatible with the **RUD-ID-POINTS[®]** as well as with common high frequency transponders/chips (ISO 15693). The transfer of the identification number is carried out either by USB or Bluetooth and can be linked up with the **RUD-ID-NET[®]** application (software), almost all Office applications (WordPad, MS Word, MS Excel, Open Office) and also with SAP or other programs.

RUD-ID-BETTER-CHECK[®] (13.56 MHz):

USB-reader for identifying the unique number of the **RUD-ID-POINT[®]**.

RUD-ID-DISPLAY-CHECK[®] (13.56 MHz):

The unique identification number is shown on the **RUD-ID-POINT[®]** which is then displayed on the integrated LCD-display. The data can be transferred to any end device capable for Bluetooth 15 metres away.

RUD-ID-NET[®]

The **RUD-ID-NET[®]** application (software) has many advantages; it is easy to use, requires no digital maintenance and ensures you manage inspections of products effectively.

- It enriches your data by providing detailed product information, inspection dates, test reports and automatic test reminders to selected employees. The benefits are endless.
- Product information and documentation such as inspection reports and product data can be easily accessed via the RUD web portal.
- Upgradeable software for different work equipment which has to be inspected regularly (f.e. work platforms, roller shutter).



ICE-Round steel link chain in special quality 120

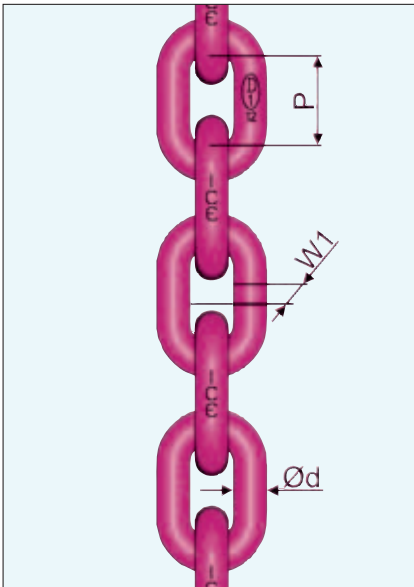

Size d [mm Ø]	6	8	10	13	16
Pitch P [mm]	18	24	30	39	48
Inside. width W1 bi min. mm	7.8	10.4	13	17	21
WLL in [t]	1.8	3.0	5.0	8.0	12.5
Proof load MPF in kN	44.1	73.5	123	196	314
Breaking load BF min. kN	71	118	196	314	503
Weight [kg/m]	0.98	1.66	2.62	4.25	6.72
Surface	pink powder coated ICE-Pink				
Order no.	7998048	7996116	7996117	7996118	7998735
Surface	phosphated in natural black				
Order no.	7994424	7994425	7994426	7994427	7994428

Minimal ultimate elongation: natural black $\geq 25\%$ ICE-PINK $\geq 20\%$
 Stamped: ICE identification on every chain link, manufacturing number and the BG approval stamp < 0.5 m

ICE identification tag with an integrated chain testing gauge – ICE-KZA

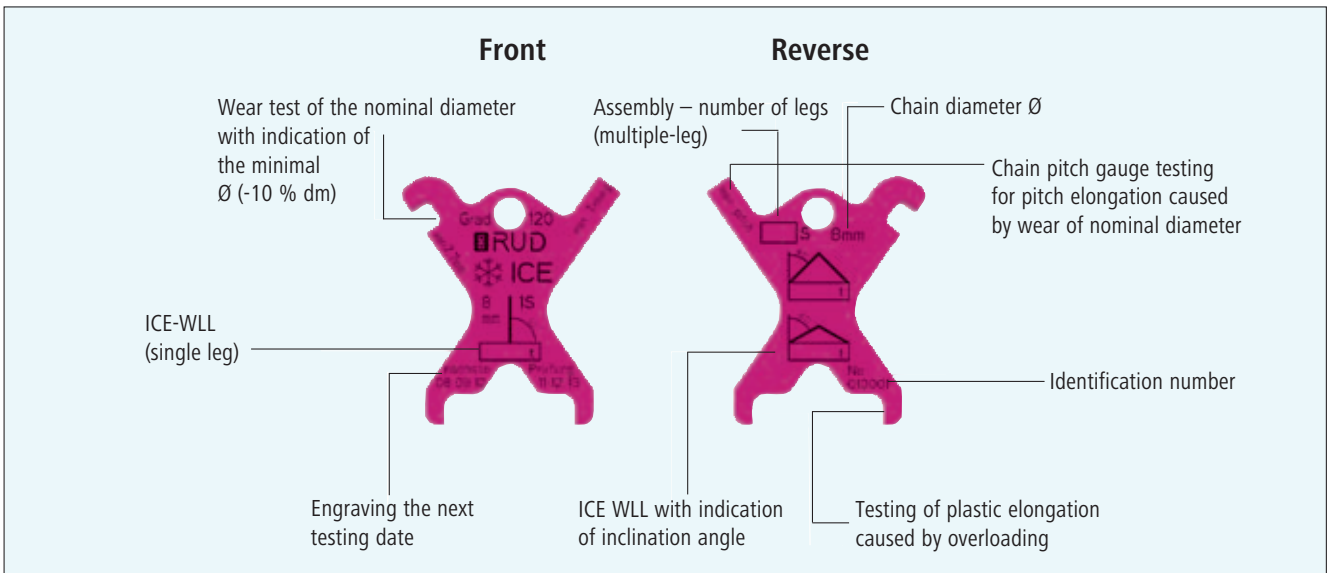

The patented idea!



Testing wear of nominal diameter



Testing of plastic elongation caused by overload



Testing for pitch elongation caused by wear of nominal diameter

ICE Grade 120 WLL chart [t]

Nominal size of sling chain in mm	1-leg	2-leg		3- and 4-leg		endless
Inclination $\angle \beta$	0°	0-45°	> 45-60°	0-45°	> 45-60°	-
Load factor	1	1.4	1	2.1	1.5	1.6
Ø 6	1.8	2.5	1.8	3.75	2.7	2.88
Ø 8	3.0	4.25	3.0	6.3	4.5	4.8
Ø 10	5.0	7.1	5.0	10.6	7.5	8.0
Ø 13	8.0	11.2	8.0	17.0*	11.8	12.8
Ø 16	12.5	17.0	12.5	26.5	19.0	20.0

Acc. to BGR 500 section 2.8, the WLL for single fall becomes valid when **unsymmetrical** load occurs at a multiple strand sling.

When requiring lower or higher WLL, up to 126 tons, please choose the corresponding chain from our VIP-Program (s. pages 30-31).

* In connection with ICE-Balancer (IW) 33 % higher WLL possible (see page 20 and 21 ICE-Balancer).

Nominal size of sling chain in mm	Endless chain				Choke hitch			
	single		double		single	double		
Inclination $\angle \beta$	0-45°	> 45-60°	0-45°	> 45-60°	0°	0-45°	> 45-60°	
Load factor	1.1	0.8	1.7	1.2	0.8	1.1	0.8	
Ø 6	2.0	1.44	3.1	2.1	1.44	2.0	1.44	
Ø 8	3.3	2.4	5.1	3.6	2.4	3.3	2.4	
Ø 10	5.5	4.0	8.5	6.0	4.0	5.5	4.0	
Ø 13	8.8	6.4	13.6	9.6	6.4	8.8	6.4	
Ø 16	14.0	10.0	21.2	15.0	10.0	14.0	10.0	

Acc. to BGR 500 section 2.8, the WLL for single fall becomes valid when **unsymmetrical** load occurs at a multiple strand sling.

Temperatur °C

When using sling chains at temperatures beyond 200°C, the permissible WLL has to be reduced. Working load in % at chain temperature of:

-60 up +200° C	above 200 up 250° C	above 250 up 300° C
100 %	90 %	60 %

RUD ICE-120-Chains and components conform fully to the requirements of EN 818 and 1677 for dynamic applications of 20,000 load cycles, with 50 % over load.

The German employer's liability assurance requires: When there are dynamic applications with high cycles (permanent operation) the mean stress corresponding to the Mechanism group 1B_m (M₃ according to DIN EN 818-7) must be reduced, for example, by using a larger chain diameter.

ICE combinations variations – Sling assembly

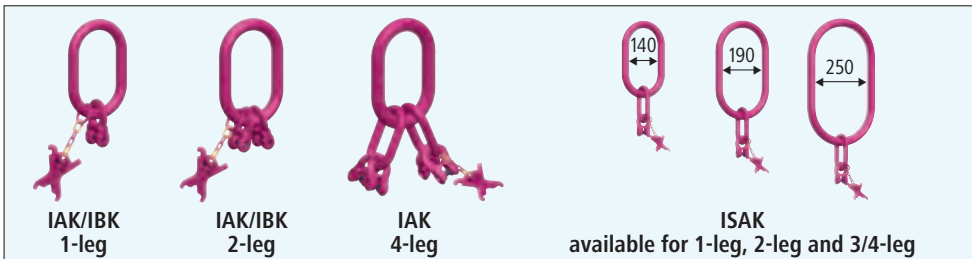

ICE Masterlinks foolproof with ICE clevis connector



Sling without shortener

Shortening variations

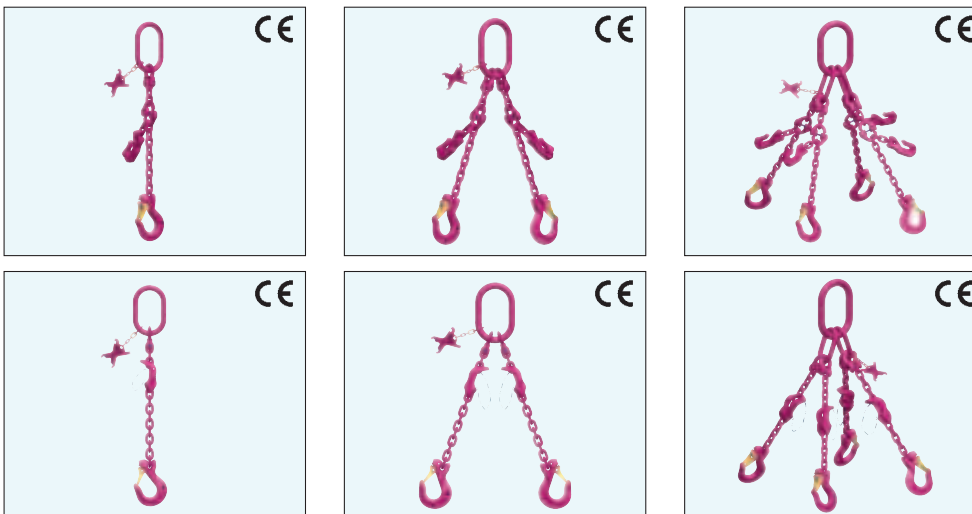

Sling shortened with ICE-shortening hook IVH

Sling shortened with ICE-Multishortening claw IMVK



End fittings

ICE-design resp. sample for denomination – complete sling assembly

Example:	Quality grade	No. of strands	Masterlink	Shortening/strands	Shortening/component	End fitting	Chain diameter	Requested reach [mm] unshortened
	ICE	G1	(IBK)	1	IMVK	ISH	13	2000
ICE-G1(IBK)-IMVK-ISH/13x2000								

ICE combinations variations – Endless chain sling

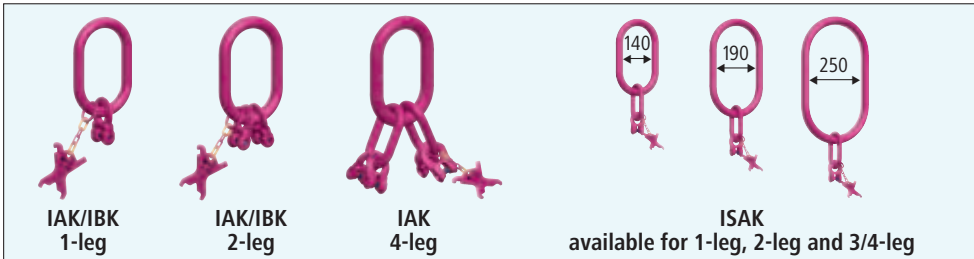

ICE Masterlinks
foolproof with
ICE clevis connector

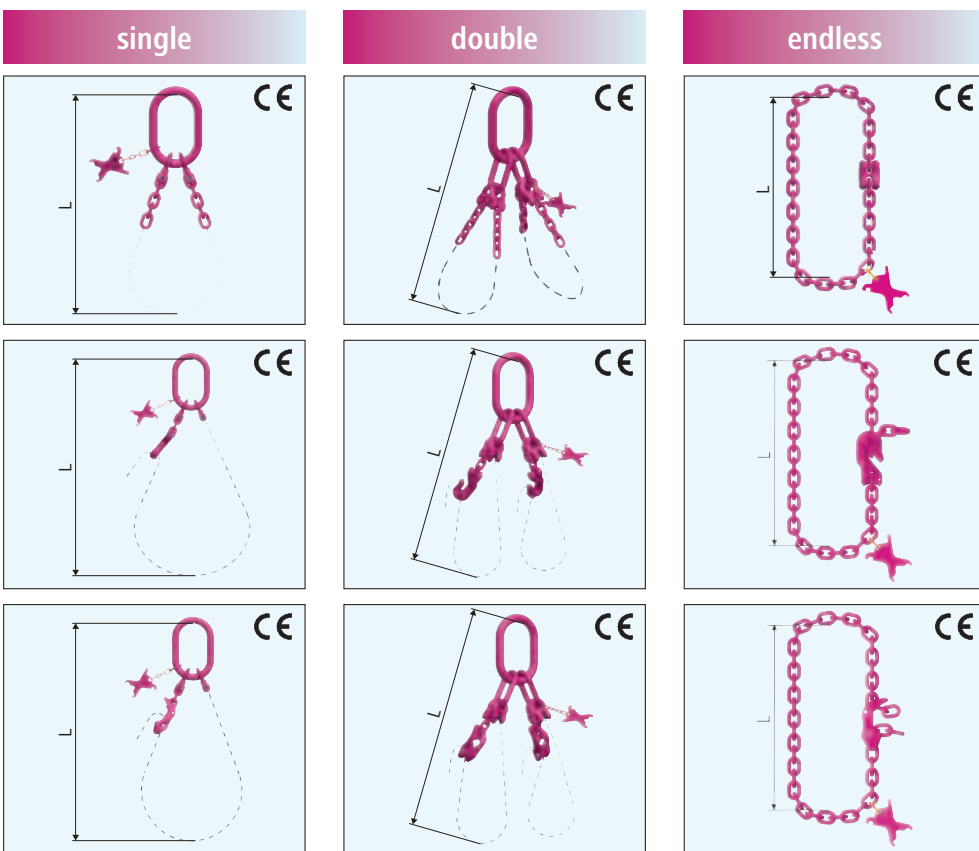

endless chain
unshortened
IH

Endless chain
shortened with
ICE-shortening coupler
IVH

Endless chain
shortened with
ICE-Multi-shortening
coupler
IMVK

ICE-design resp. sample for denomination – endless chain sling

Example:	Grade	Endless chain	Single (E)/ Double (D)	Without shortening (U)/ shortened (V)	Shortening/ component	Chain diameter	Requested reach [mm] unshortened
	ICE	KR	single = E	shortened = V	IVH	8	2000
ICE-KRE (IVH)-8x2000							

Handling:

Chains and components of ICE-Grade 120 must not be combined with chains and components of other manufacturers or quality classes.

Attention:

Incorrect handling and use of these lifting chains can lead to material and/or personal damage!

Important safety information must be observed:

DIN-EN 818, DIN-EN 1677, BGR 500 chapter 2.8, EU-Directives 2006/42/EG and manufacturer's manual, BGI 556.

We do not assume liability for damage which in respect of disregard of these norms and safety information.

ICE-Standard-Master Links with ICE weld-in connector

All **masterlinks** shown at this page are equipped with an allside flexible clevis connector. This leads to a fool-proof connection in regard of the chain diameter and number of legs.

The **masterlink** is completed by an identification tag (**KZA**) with an integrated chain gauge function.

Inclusive RUD-ID-Point®.

IAK-RG-Masterlinks

The dimensions are according to masterlink shape A acc. to DIN 5688, but one size bigger.

IBK-RG-Masterlinks

The inside width fits high tensile load hooks from hoists.

IAK-RG-1- and IBK-RG-1-masterlinks or endlinks with weld-in ICE-clevis connector

Chain	WLL [t]	Type	Ø A	B	C	T	Weight [kg/pc.]	Ref. No.
6	1.8	IAK-RG-1-6 (IA-RG-1-6)	13	60	110	144	0.57 (0.5)	7903009 (7903090)
8	3.0	IAK-RG-1-8 (IA-RG-1-8)	16	75	135	178	1.23 (1.1)	7903010 (7903091)
10	5.0	IAK-RG-1-10 (IA-RG-1-10)	22	90	160	213	2.19 (2.0)	7903011 (7903092)
13	8.0	IAK-RG-1-13 (IA-RG-1-13)	26	100	180	247	3.58 (3.4)	7903012 (7903093)
16	12.5	IAK-RG-1-16 (IA-RG-1-16)	32	140	260	343	7.20 (7.0)	7903013 (7903094)
6	1.8	IBK-RG-1-6 (IB-RG-1-6)	13	34	70	105	0.43 (0.35)	7903041 (7903095)
8	3.0	IBK-RG-1-8 (IB-RG-1-8)	18	40	85	129	0.92 (0.8)	7903042 (7903096)
10	5.0	IBK-RG-1-10 (IB-RG-1-10)	22	50	115	169	1.76 (1.5)	7903043 (7903097)
13	8.0	IBK-RG-1-13 (IB-RG-1-13)	26	65	140	207	3.0 (2.8)	7903044 (7903098)
16	12.5	IBK-RG-1-16 (IB-RG-1-16)	32	75	170	253	5.5 (5.3)	7903045 (7903099)

- ICE connecting bolts and securing sleeve pin pre-assembled
- Also available as end link (IA-1), without identification tag

IAK-RG-2- and IBK-RG-2-master link with two pre-assembled ICE-connectors

Chain	WLL [t]	Type	Ø A	B	C	T	Weight [kg/pc.]	Ref. No.
6	2.5/1.8	IAK-RG-2-6	16	75	135	171	1.0	7903051
8	4.25/3.0	IAK-RG-2-8	22	90	160	203	2.1	7903052
10	7.1/5.0	IAK-RG-2-10	26	100	180	233	3.5	7903053
13	11.2/8.0	IAK-RG-2-13	32	110	200	267	6.7	7903054
16	17.0/12.5	IAK-RG-2-16	36	180	340	423	13.0	7903055
6	2.5/1.8	IBK-RG-2-6	13	34	70	105	0.57	7903075
8	4.25/3.0	IBK-RG-2-8	18	40	85	129	1.21	7903076
10	7.1/5.0	IBK-RG-2-10	22	50	115	169	2.34	7903077
13	11.2/8.0	IBK-RG-2-13	26	65	140	207	4.24	7903078
16	17.0/12.5	IBK-RG-2-16	32	75	170	253	7.83	7903079

IAK-RG-4 master link

with 4 in 2 intermediate links pre-assembled ICE-connectors

Chain	WLL [t]	Type	Ø A	B	C	Ø D	E	F	T	Weight [kg/pc.]	Ref. No.
6	3.75/2.7	IAK-RG-4-6	18	90	160	13	34	70	265	2.04	7903085
8	6.3/4.5	IAK-RG-4-8	26	100	180	18	40	85	309	4.59	7903086
10	10.6/7.5	IAK-RG-4-10	32	110	200	22	50	115	369	8.37	7903087
13	17.0/11.8	IAK-RG-4-13	36	140	260	26	65	140	467	14.44	7903088
16	26.5/19.0	IAK-RG-4-16	46	190	350	32	75	170	603	28.87	7903089

IAK-RG-master links:

suitable up to crane hook size no. (DIN 15401)

Size	6	8	10	13	16
IAK-RG 1	No. 2.5	No. 5	No. 6	No. 8	No. 16
IAK-RG 2	No. 5	No. 6	No. 8	No. 10	No. 25
IAK-RG 3/4	No. 6	No. 8	No. 10	No. 16	No. 32

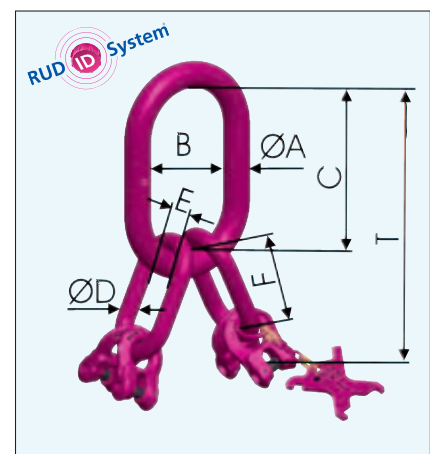
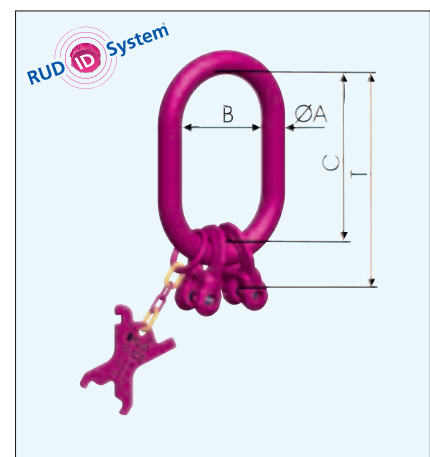
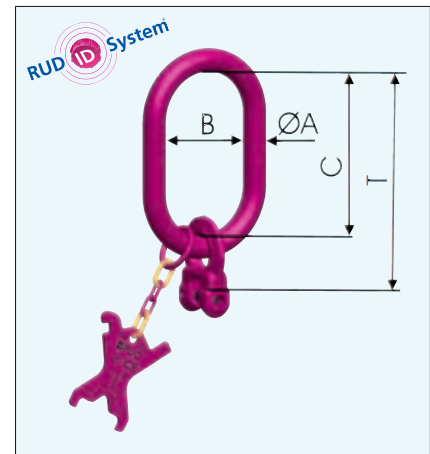

ICE-Special Masterlinks with weld-in ICE-clevis connector

All **masterlinks** shown at this page are equipped with an allside flexible clevis connector. This leads to a fool-proof connection in regard of the chain diameter and number of legs.

The **masterlink** is completed by an identification tag (KZA) with an integrated chain gauge function.

Inclusive RUD-ID-Point®.

The bigger increment of the inside width "B" avoids an prohibited usage (BGR 500, chapter 2.8) and reduces wear at the crane hook.

ISAK-RG-1-leg master link with a pre-assembled ICE-connector in the intermediate link

Chain	WLL [t]	Type	Ø A	B	C	Ø D	E	F	T	Weight [kg/pc.]	Ref. No.
6	1.8	ISAK-RG-1-6/140	18	140	260	13	34	70	365	2.29	7903182
8	3.0	ISAK-RG-1-8/140	22	140	260	18	40	85	389	3.94	7903183
10	5.0	ISAK-RG-1-10/140	26	140	260	22	50	115	429	6.34	7903184
13	8.0	ISAK-RG-1-13/140	32	140	260	26	65	140	467	9.44	7903185
6	1.8	ISAK-RG-1-6/190	22	190	350	13	34	70	455	3.82	7903186
8	3.0	ISAK-RG-1-8/190	26	190	350	18	40	85	479	6.03	7903187
10	5.0	ISAK-RG-1-10/190	32	190	350	22	50	115	519	10.02	7903188
13	8.0	ISAK-RG-1-13/190	36	190	350	26	65	140	557	13.90	7903189
8	3.0	ISAK-RG-1-8/250	36	250	460	18	40	85	589	12.86	7903190
10	5.0	ISAK-RG-1-10/250	36	250	460	22	50	115	629	14.32	7903191
13	8.0	ISAK-RG-1-13/250	36	250	460	26	65	140	667	16.33	7903192
16	12.5	ISAK-RG-1-16/250	40	250	460	32	75	170	713	23.14	7903193

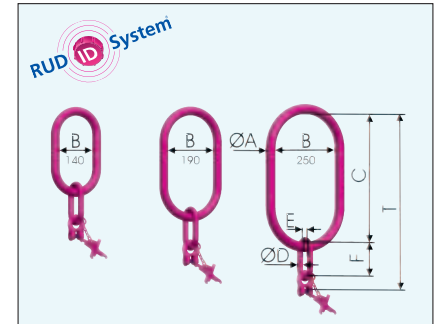

ISAK-RG-2-leg master link with 2 in each case pre-assembled ICE-connectors

Chain	WLL [t]	Type	Ø A	B	C	Ø D	E	F	T	Weight [kg/pc.]	Ref. No.
6	2.5/1.8	ISAK-RG-2-6/140	18	140	260	13	34	70	365	2.36	7903194
8	4.25/3.0	ISAK-RG-2-8/140	22	140	260	18	40	85	389	4.03	7903195
10	7.1/5.0	ISAK-RG-2-10/140	26	140	260	22	50	115	429	6.63	7903196
13	11.2/8.0	ISAK-RG-2-13/140	32	140	260	26	65	140	467	10.47	7903197
6	2.5/1.8	ISAK-RG-2-6/190	22	190	350	13	34	70	455	3.89	7903198
8	4.25/3.0	ISAK-RG-2-8/190	26	190	350	18	40	85	479	6.13	7903199
10	7.1/5.0	ISAK-RG-2-10/190	32	190	350	22	50	115	519	10.30	7903200
13	11.2/8.0	ISAK-RG-2-13/190	36	190	350	26	65	140	557	14.93	7903201
8	4.25/3.0	ISAK-RG-2-8/250	36	250	460	18	40	85	589	12.95	7903202
10	7.1/5.0	ISAK-RG-2-10/250	36	250	460	22	50	115	629	14.61	7903203
13	11.2/8.0	ISAK-RG-2-13/250	36	250	460	26	65	140	667	17.37	7903204
16	17.0/12.5	ISAK-RG-2-16/250	40	250	460	32	75	170	713	25.16	7903205

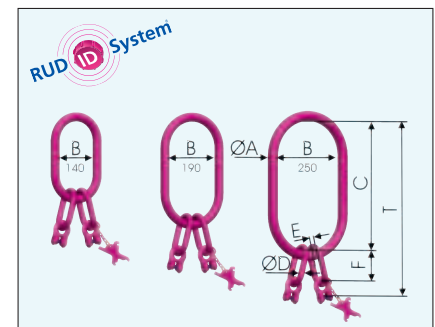

ISAK-RG-4-leg master link with 4 in 2 intermediate links pre-assembled ICE-connectors

Chain	WLL [t]	Type	Ø A	B	C	Ø D	E	F	T	Weight [kg/pc.]	Ref. No.
6	3.75/2.7	ISAK-RG-4-6/140	22	140	260	13	34	70	365	3.24	7903206
8	6.3/4.5	ISAK-RG-4-8/140	26	140	260	18	40	85	389	5.47	7903207
10	10.6/7.5	ISAK-RG-4-10/140	32	140	260	22	50	115	429	9.70	7903208
6	3.75/2.7	ISAK-RG-4-6/190	26	190	350	13	34	70	455	5.34	7903209
8	6.3/4.5	ISAK-RG-4-8/190	32	190	350	18	40	85	479	9.14	7903210
10	10.6/7.5	ISAK-RG-4-10/190	36	190	350	22	50	115	519	13.16	7903211
13	17.0/11.8	ISAK-RG-4-13/190	40	190	350	26	65	140	557	19.14	7903212
8	6.3/4.5	ISAK-RG-4-8/250	36	250	460	18	40	85	589	13.45	7903213
10	10.6/7.5	ISAK-RG-4-10/250	36	250	460	22	50	115	629	15.60	7903214
13	17.0/11.8	ISAK-RG-4-13/250	40	250	460	26	65	140	667	22.12	7903215
16	26.5/19.0	ISAK-RG-4-16/250	47	250	460	32	75	170	713	32.98	7903216

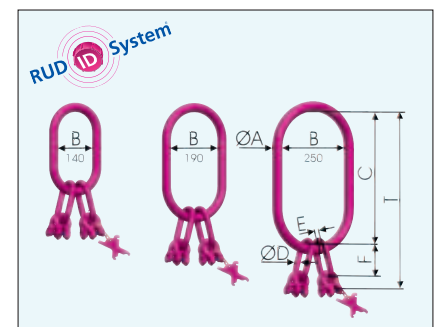

ICE-RG special master links: suitable up to simple hook Nr. (DIN 15401)

ISAK-RG Maß B = 140	No. 16
ISAK-RG Maß B = 190	No. 32
ISAK-RG Maß B = 250	No. 50

*Attention: Master Links of the size 13 and 16 are equipped with a special identification tag. A tag with gauge function will be additionally attached to the shipment for size 13 and 16.

IVS – ICE-Connecting link

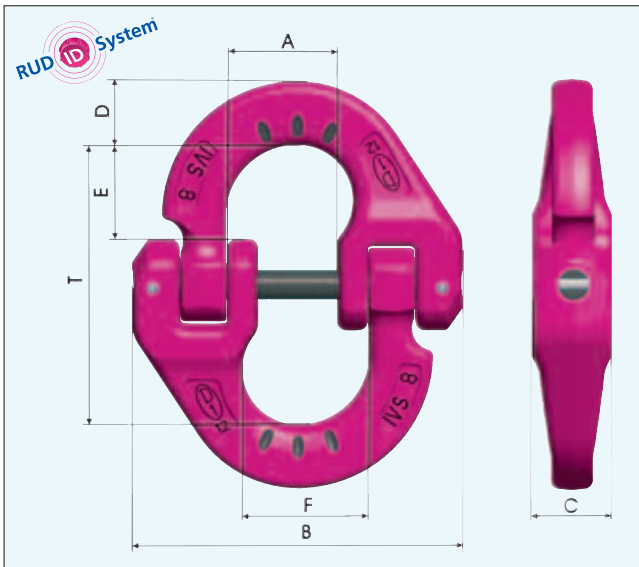

The all-purpose ICE-Connecting link

- Lifting points, shackles and plate clamps can be attached into the halves of the connecting link.
- Form and function are patent pending
- No kinking of pre-assembled chain possible.
- The halves are adjustable at will between each others.
- Patented wear markings.
- Inclusive RUD-ID-Point®.

Chain	WLL [t]	Type	A	B	C	D	E	F	T	[kg/pc.]	Ref. No.
6	1.8	IVS-6	18	55	13	11	17	21	46	0.12	7901471
8	3.0	IVS-8	24	70	17.5	14	23	27.5	61	0.29	7901472
10	5.0	IVS-10	28	88	22	17	27	32	74	0.57	7901473
13	8.0	IVS-13	34	111	28	23	33	40	93	1.2	7901474
16	12.5	IVS-16	39	130	33	27	37	46	108	2.0	7901475

IVH – ICE-VH-Shortening hook

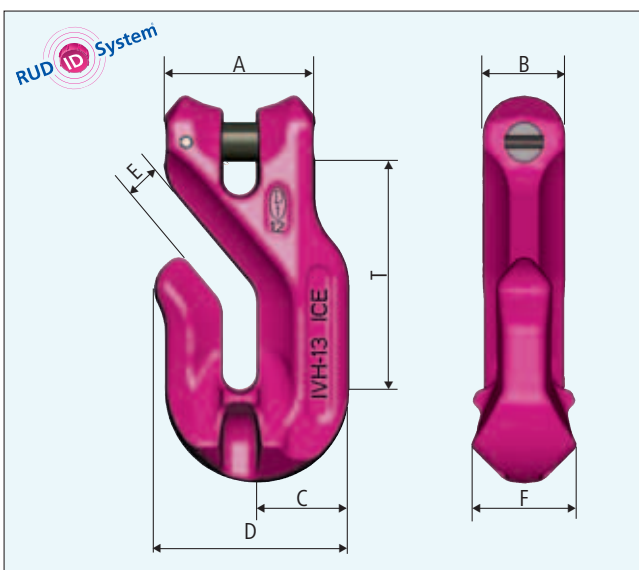

- No reduction of ICE WLL.
- High dynamic strength.
- Due to offset leading-in groove chain hindered fall-out of slack chain.
- Enlarged tip of hook avoids incorrect use, i.e. attaching of chain.
- Acc. to Standard DIN 5692. Depth of chain groove > 5 x chain diameter.
- Completely assembled with connecting bolt and sleeve pin.
- Inclusive RUD-ID-Point®.

Chain	WLL [t]	Type	A	B	C	D	E	F	T	[kg/pc.]	Ref. No.
6	1.8	IVH-6	34	18	20	44	7.5	22	53	0.27	7900129
8	3.0	IVH-8	43	24	26	55	9.5	29	67	0.5	7900133
10	5.0	IVH-10	55	30	34	71	12	38	86	1.2	7900134
13	8.0	IVH-13	70	38	43	90	15	48	105	2.5	7900136
16	12.5	IVH-16	86	46	53	110	18.5	59	128	4.5	7900138

IH – ICE-H-Connector



Endless chain with H-Connector [WLL in t]

ICE IKR-H	Ø 6 mm	Ø 8 mm	Ø 10 mm	Ø 13 mm	Ø 16 mm
endless chain in choke hitch	2.88	4.8	8.0	12.8	20.0
0-45°	2.0	3.3	5.5	8.8	14.0
	45-60°	1.44	2.4	4.0	6.4

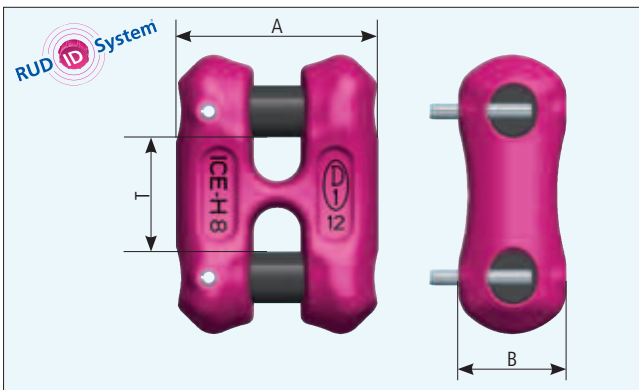

- Fast, easy and economical endless-making of chains
- Pitch of the H-Connector analogue chain pitch
- Suitable for the repairing of multiple strand slings
- More compact and therefore easier to handle than conventional chain locks
- Heat-treated body, therefore more wear resistant
- Economically formed
- Enhanced slide over corners
- Very jointed: adapts to the chain as to the component
- Inclusive RUD-ID-Point®.

Chain	Type	A	B	T	[kg/pc.]	Ref. No.
6	IH-6	34	19.6	18	0.11	7901922
8	IH-8	45	25.5	24	0.26	7901453
10	IH-10	56	31.5	30	0.55	7901454
13	IH-13	73	40	39	1.16	7901455
16	IH-16	89	49	48	2.16	7901924



Examples – IVS-IVH application

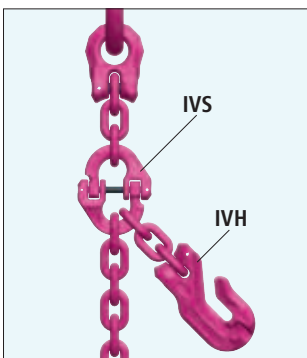

Connecting link with shortening hook

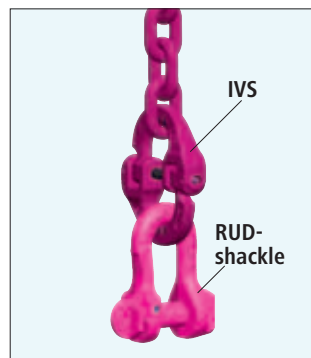

Connecting link with shackle



Slind chain with IVH

Type	IVS-connection suitable to VIP shackle
IVS-6	VV-SCH 8 – 2.5 t up to VV-SCH 13 – 6.7 t
IVS-8	VV-SCH 10 – 4 t up to VV-SCH 16 – 10 t
IVS-10	VV-SCH 13 – 6.7 t up to VC-SCH 4.0 – 14 t
IVS-13	VV-SCH 16 – 10 t up to VC-SCH 5,0 – 22.4 t
IVS-16	VC-SCH 4 – 14 t up to VC-SCH 6.0 – 28.0 t

IMVK – ICE-Multishortening claw

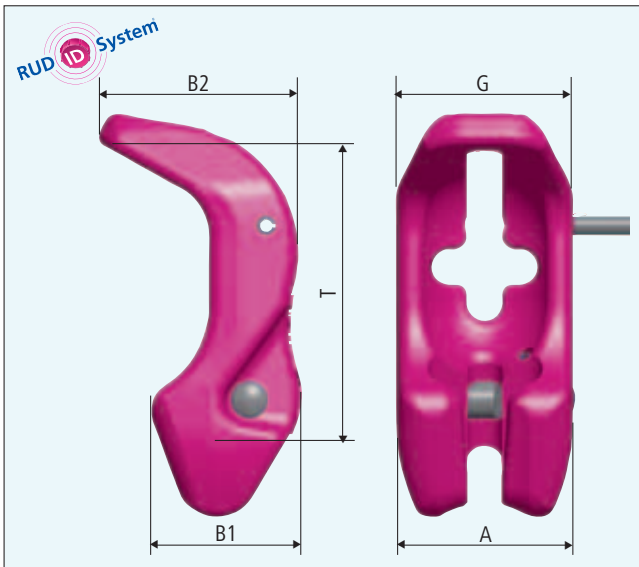

- Improvement of the VMVK with modification to the ICE requirements.
- Assembled captive into through going chain strand
- Can be assembled relocatable at any place within the chain strand
- No additional chain or connection part necessary.
- Ideal support of chain due to chain link shaped pocket- therefore no reduction of WLL.
- The robust, spring supported securing pin avoids unintended loosening of attached chain when either loaded or not.
- Fulfills DIN 5692
- Inclusive RUD-ID-Point®.

Chain	WLL [t]	Type	A	B1	B2	G	T	[kg/pc.]	Ref. No.
6	1.8	IMVK-6	35	34	40	36	66	0.3	7900985
8	3.0	IMVK-8	46	41	52	48	88	0.55	7900981
10	5.0	IMVK-10	58	50	64	60	110	1.1	7900983
13	8.0	IMVK-13	74	64	86	76	143	2.4	7900984
16	12.5	IMVK-16	91	79	105	98	176	4.4	7900986

IMVK – Use

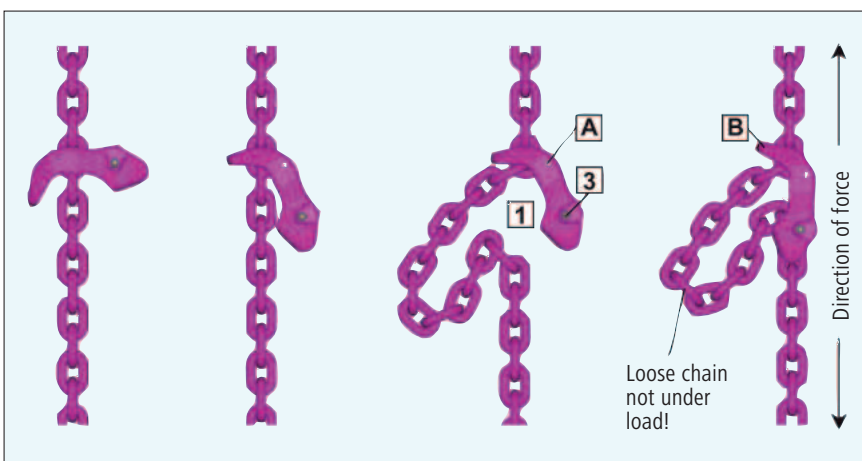

1. Attach loose chain strand through cross of IMVK and secure by hammering the sleeve pin A in.
2. When chain is unloaded, position chain link into pocket 1, press securing knob 3 and pull chain down.
3. Release securing knob and control locking.
4. Release, backwards (securing knob 3 must be pushed).

Attention: When IMVK is used without securing pin A, chain must be always totally engaged into the locking groove B. When pulling/lifting the shortened chain assembly attention must be paid to ensure that the chain remains in the locking slot!

ICE-CURT-K – Bar spindle tensioner with locking handle for lifting – light and robust

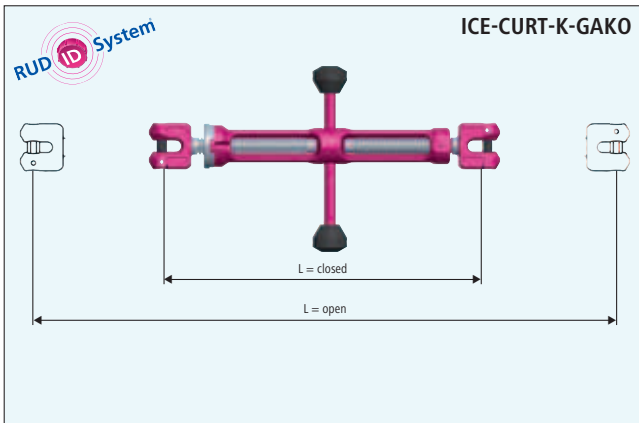

ICE-CURT-K-GAKO

- With user friendly and space-saving tensioning lever.
- Exceeds the requirements of EN 12195-3.
- User friendly turn-loose securing, providing theft protection done by padlock (e.g. type ABUS 85/40 HB), 100 % crack inspected, all load bearing parts drop forged.
- Easy to clean and lubricate, innovative forged design-light in weight and robust, Patent pending.
- Made in Germany, user friendly – even with gloves.
- It is only possible to adjust the tensioner unloaded.
- Inclusive RUD-ID-Point®.

Chain Ø	Type	Lashing WLL [t]	L-open [mm]	L-closed [mm]	Reach [mm]	Weight [kg/pc.]	Ref. No.
6	ICE-CURT-K-6-GAKO	1.8	400	260	140	1.8	7904448
8	ICE-CURT-K-8-GAKO	3.0	520	350	170	3.2	7904449
10	ICE-CURT-K-10-GAKO	5.0	532	362	170	3.6	7904450
13	ICE-CURT-K-13-GAKO	8.0	830	530	300	6.9	7904451
16	ICE-CURT-K-16-GAKO	12.5	962	612	350	12.2	7904452

Millimeter accurate length adjustment with ICE-CURT-K-GAKO

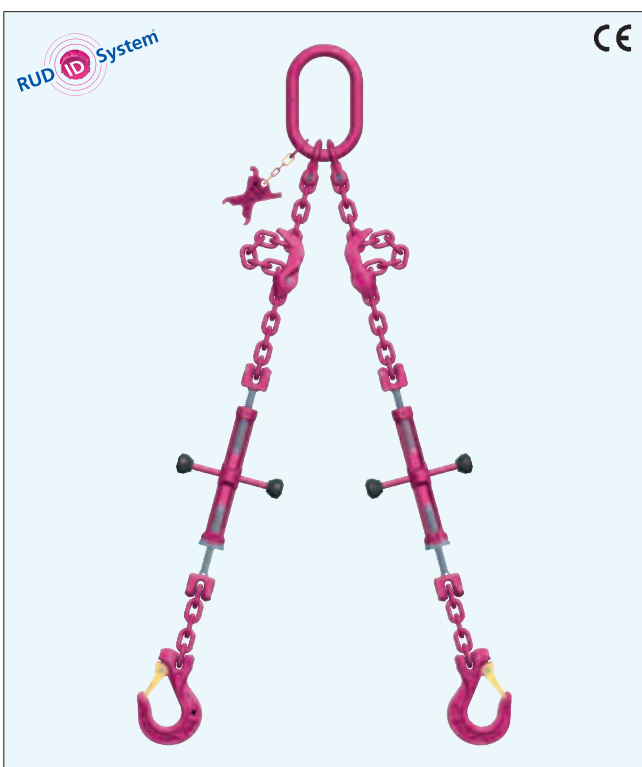

- For an exact length adjustment on a chain sling.
- Length can be precisely adjusted by the right/left threaded spindles
- It must only be adjusted in unloaded condition!
- Lowering only
- Load cannot be lifted!

IW – ICE-Balancer

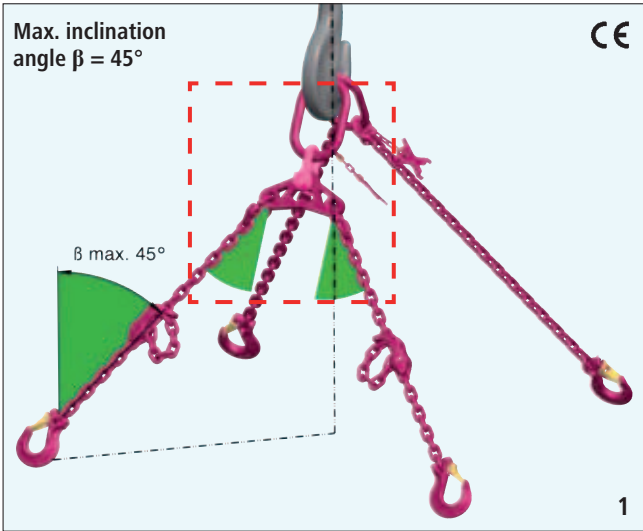

With a 4-leg assembly, maximum 3 legs can be considered as bearing only, in unfavourable cases 2 ones only

Our advice:

By using the ICE 2x2 assembly with Balancer in the shown configuration the **load will equally be distributed** to all 4 legs, resulting in a **33% increased WLL** compared with a standard 4-leg assembly (refer to table).

Comparison ICE 4-leg assembly / ICE 2x 2-leg assembly with balancer

Chain [mm]	WLL ICE 4-leg assembly	WLL (t) ICE 2x2-leg assembly with balancer up to angle $\beta = 45^\circ$
6	3.75	5.1
8	6.3	8.4
10	10.6	14.1
13	17	22.6
16	26.5	35.3

When using the ICE assembly with Balancer, you have to consider the following:

- The load has to be symmetrical
- The inclination angle β must not be beyond 45° (see graphics 1 and 2)
- The inclination position of the balancer must not exceed 10° (see graphics 3, 4 and 5)
- For detailed information on the ICE-Balancer, please refer to operation manual

For higher WLL's with angle $\beta = 15^\circ$ or $\beta = 30^\circ$, please refer to operation manual.

Attention: The 2-leg assembly with balancer must not be used as 2-leg assembly in stand-alone version. Any working means used for lifting of loads have to avoid that the load may unintentionally shift in a dangerous way (see BetrSichV, annexe 1, paragr. 3.2.3).

In case of unsymmetrical loads, please contact the manufacturer. We will always be prepared to assist you!

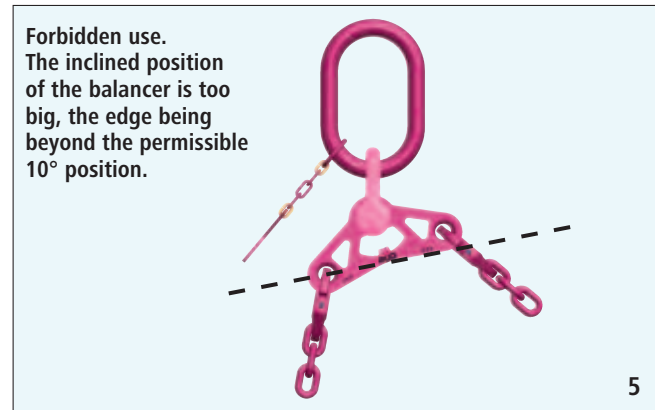
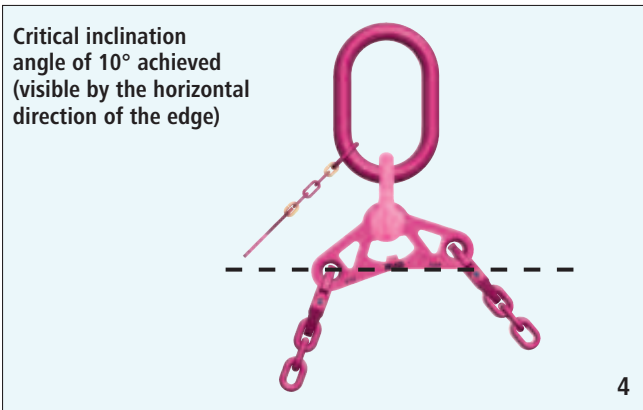
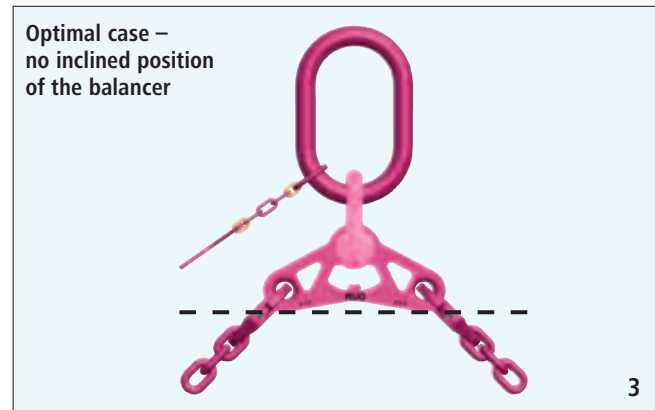
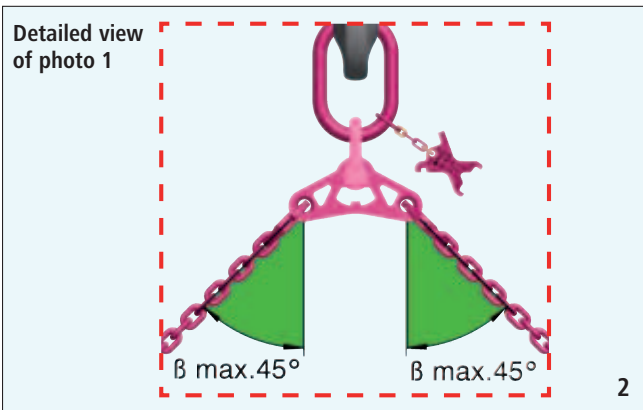

Assembly of ICE-Balancing head

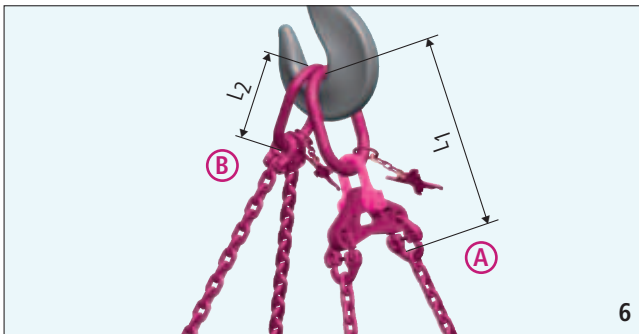

The ICE-Balancer head IWK-25 (A) comprises:

- IA link with identification tag
- VIP shackle
- ICE-Balancer
- 2 ICE-Connectors

Chain [mm]	Type ICE-Balancer head (A)	Sizes IAK and IA link [mm]	Connection at top	Connection at bottom	Pitch of balancer head L1 [mm]	Weight of balancer head [kg/pc.]	Art. No. ICE-Balancer head
6	IWK-2S-6	18X90X160	VV-SCH10 (4t)	IVS 6	301	2.33	7904654
8	IWK-2S-8	26X100X180	VV-SCH13 (6.7t)	IVS 8	363	5.39	7904655
10	IWK-2S-10	32X110x200	VV-SCH16 (10t)	IVS 10	423	9.99	7904656
13	IWK-2S-13	36X140X260	VC-SCH 5.0 (22.4t)	IVS13	555	17.5	7904657
16	IWK-2S-16	46X190X350	VC-SCH 6.0 (31.5t)	IVS16	698	37.54	7904658

Chain [mm]	Type ICE 2-leg master link for assemblies with balancer (B)	Sizes IAK and IA link [mm]	Pitch 2-leg IAK L2 [mm]	Weight 2-leg IAK [kg/pc.]	Art. No. 2-leg IAK
6	IAK 2S-6	18X90X160	265	1.8	7904659
8	IAK 2S-8	26X100X180	309	4.09	7904660
10	IAK 2S-10	32X110x200	369	7.37	7904661
13	IAK 2S-13	36X140X260	467	12.44	7904662
16	IAK 2S-16	46X190X350	603	24.87	7904663

IW – ICE-Balancer

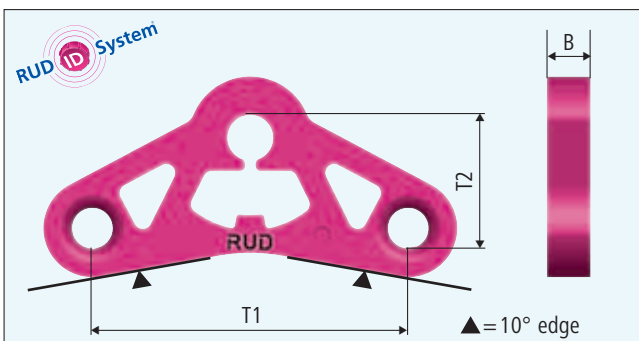

- Connection for balancer at top: connection by shackle
- Connection for balancer at bottom: ICE-Connectors
- Easy visibility of the critical inclined position of 10° by the special shape at the bottom side of the balancer
- Powder coated in ICE pink
- For detailed information regarding the ICE-Balancer, please refer to the operation manual
- Including RUD-ID-Point®.

Chain [mm]	Type	WLL balancer 0-45°	T1 [mm]	T2 [mm]	B [mm]	Weight [kg]	Art. No.
6	IW-6	2.5	110	46	15	0.49	7904367
8	IW-8	4.25	150	59	20	1.15	7904370
10	IW-10	7.1	180	76	25	2.4	7904372
13	IW-13	11.2	240	91	30	4.37	7904375
16	IW-16	17	300	120	35	8.8	7904255

ISH – ICE-Star Hook

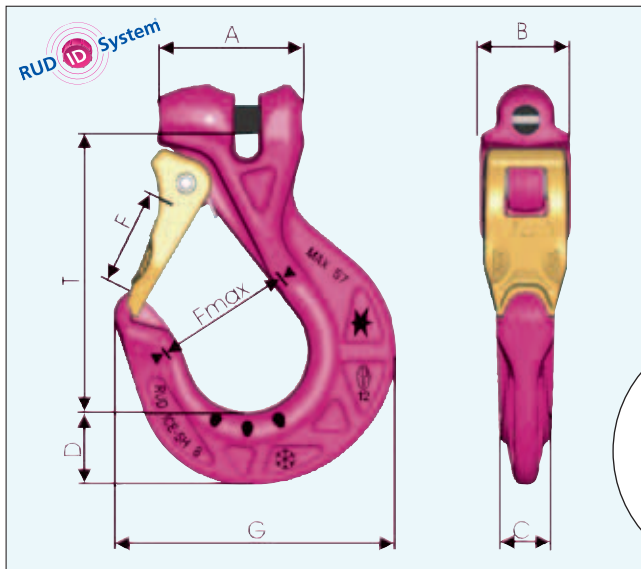

ICE Star Hook – suitable down to **-60°C**.

- Edge protection – increased section at the side and top of the hook for the safety latch
- Wear ribs – which protect the first chain link into the clevis
- No protruding hook tip
- Patented wear marks that, without measuring, show instantly when the hook has reached the statutory allowable wear limit and must be replaced

- Due to its innovative construction, the skeletal design ICE-SH Star Hook is up to 25 % lighter than Grade 80 hooks of the same WLL, i.e. the next larger size.
- The large width of the throat of the hook is the same dimensionally as the millionfold successful Granit-Super Hook – of the next larger size – **so not everything was reduced!**
- The safety latch of the RUD-Hook family, the GSH, SH, Cobra and ICE-Star Hook are interchangeable. (Make sure to select the correct diameter) – easy to supply spare parts.
- All the benefits of the VIP-Cobra-Hook are included and improved:
- Marker points to check the width of the hook on inspection – (often copied!)

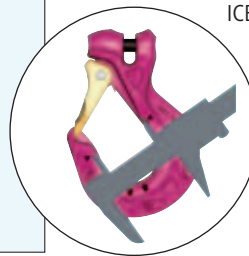

- Forged, tempered and ergonomic safety latch with a triple-coiled, double-leg spring in stainless steel. Exceeds by far, the EN standard values for side loading
- Inclusive RUD-ID-Point®.

Chain	WLL [t]	Type	A	B	C	D	F	Fmax.	G	T	[kg/pc.]	Ref. No.
6	1.8	ISH-6	48	28	18	26	30	51	97	97	0.69	7998179
8	3.0	ISH-8	45	36	20	29	36	58	112	110	1.1	7995254
10	5.0	ISH-10	71	43	25	37	41	66	135	127	1.9	7995255
13	8.0	ISH-13	85	52	31	48	50	80	163	153	3.5	7995256
16	12.5	ISH-16	94	58	38	56	58	96	196	184	5.5	7995257

Safety Set



Chain	Type	[kg/pc.]	Ref. No.
6	Si-Set ICE-SH-6	0.09	7100300
8	Si-Set ICE-SH-8	0.11	7100301
10	Si-Set ICE-SH-10	0.15	7100302
13	Si-Set ICE-SH-13	0.24	7100303
16	Si-Set ICE-SH-16	0.40	7900419



Consisting of a forged safety latch, triple-coiled corrosion resistant double-leg spring and a retaining pin.

Only available as a complete set.

Easy assembly and removal using only hammer and drift punch.

IAGH – ICE-Clevis self locking hook

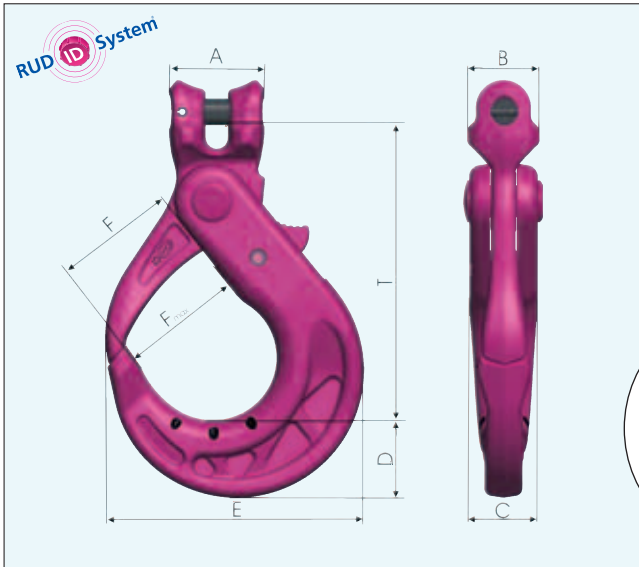

IAGH – suitable to -60°C.

- Due to its innovative construction, the skeletal design ICE-SH Star Hook is up to 30 % lighter than Grade 80 hooks of the same WLL, i.e. the next larger size.
- The large width of the throat of the hook has the same dimension like the Grade 80 hook.
- Locking device designed ergonomically, easy to handle with anti-slip surface – no danger of squeezing.
- Marker points to check the width of the hook on inspection – (often copied)!

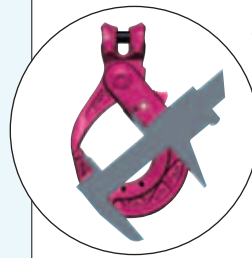

- Wear ribs – which protect the first chain link into the clevis
- Thickened tip of the hook – prevents incorrect and dangerous use of the hook tip

- Patented wear marks that, without measuring, show instantly when the hook has to be taken out of service.
- Inclusive RUD-ID-Point®.

Chain	WLL [t]	Type	A	B	C	D	E	F	F _{max.}	T	[kg/pc.]	Ref. No.
6	1.8	IAGH-6	34	24	27	28	97	44	60	113	0.9	7900085
8	3.0	IAGH-8	45	31	30	31	106	48	66	124	1.2	7997691
10	5.0	IAGH-10*	50	38	36	40	136	61	81	154	2.4	7997692
13	8.0	IAGH-13	73	50	44	51	173	78	107	200	4.9	7997693
16	12.5	IAGH-16	90	61	49	53	192	85	121	232	7.4	7900086

*For applications at dump trucks see page 24 IMAGH-10.

Safety Set for IAGH

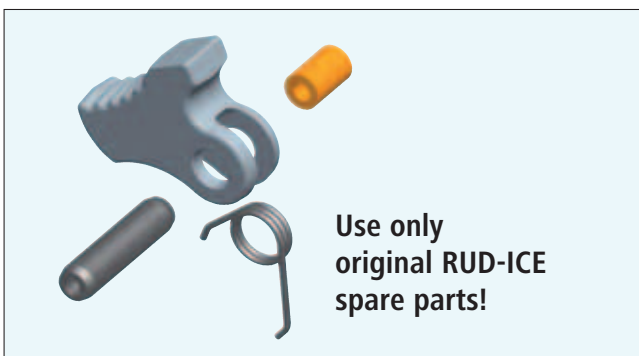

- Only available as a complete set.
- Consisting of a drop forged locking device, a double coiled stainless spring, a retaining pin plus mounting sleeve.
- Easy assembly and removal using only hammer and drift punch.

Chain	Type	[kg/pc.]	Ref. No.
6	Si-Set IAGH-6	0.03	8503759
8	Si-Set IAGH-8	0.04	8503713
10	Si-Set IAGH-10	0.06	7998255
13	Si-Set IAGH-13	0.14	8503714
16	Si-Set IAGH-16	0.2	8503760

New!

IWH – ICE-Foundry Hook

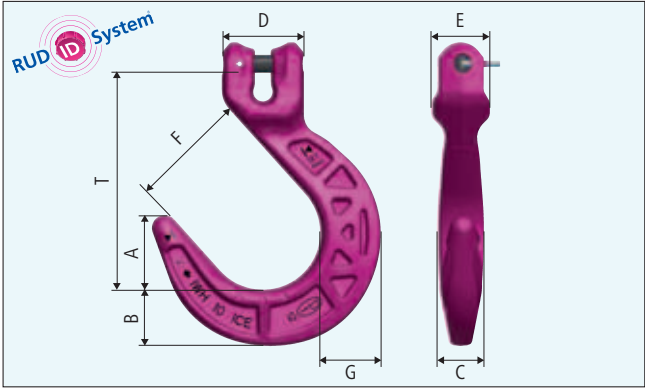

- Optimized in terms of weight in Skeleton technique
- With fool-proof clevis connection
- Robust cross section (sizes C and G) against increased bending forces
- Protection- and wear edges (size E)
- $F_{max.}$ = distance of the marking points
- Patented wear marks in the hook ground
- Use only where an unintentional unhooking is impossible (evaluation of danger)
- Including RUD-ID-Point®.

Typ	WILL [t]	A	B	C	D	E	F	G	T	[kg/pc.]	Ref. No.
IWH-6	1.8	41	31	24	42	29	64	32	121	1	7904360
IWH-8	3.0	49	37	29	50	36	76	4	143	1.76	7904361
IWH-10	5.0	58	44	31	64	46	90	47	168	3.0	7903847
IWH-13	8.0	66	50	39	75	56	100	55	193	4.7	7904362
IWH-16	12.5	75	56	43	90	58	114	61	208	6.5	7904363

IMEG – ICE-Dumper truck suspension-ring **IMAGH – ICE-Dump truck-Automatic-Clevis hook**

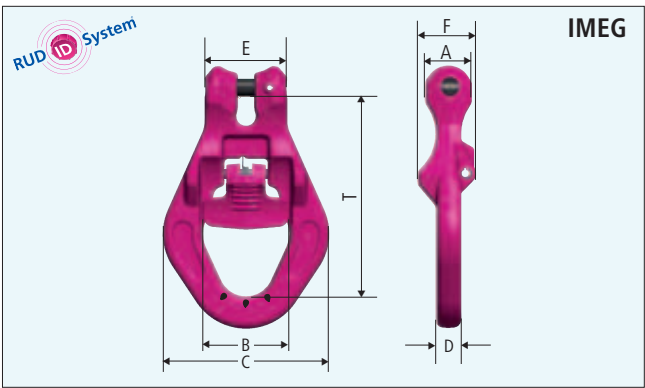

- Quick, robust and user friendly
- Quick attachment, without separate unlatching
- Simplified hinge and unhinge of the suspension ring by ergonomic designed locking latch
- Locking latch with slide resistant shape
- Protection ribs to prevent the locking latch from damage and impact shocks
- Suitable for standardised dump truck studs acc. to DIN/EN 30720
- Inclusive RUD-ID-Point®.

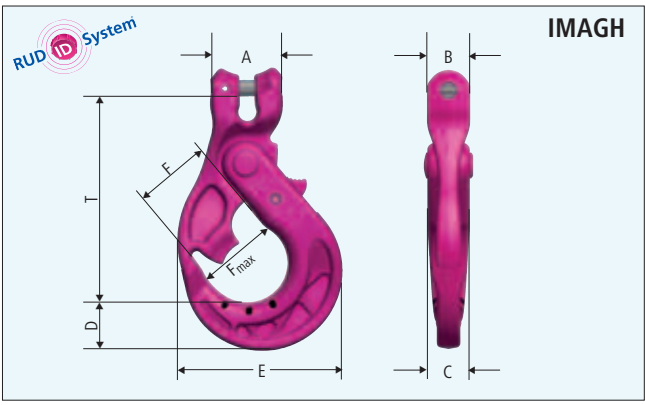

- Suitable for standardised dump truck studs acc. to DIN/EN 30720
- Easy operation of the pin and hook securing
- Chain connection without danger of confusion
- Markings for the inspection of the hook width
- Patented wear markings, which show the wear, without using a caliper
- Slide resistant operation of the securing lever without risk of injury
- Inclusive RUD-ID-Point®.

Chain	WLL [t]	Type	A	B	C	D	E	F	F _{max.}	T	[kg/pc.]	Ref. No.
10	5.0	IMEG-10	37	66	128	20	64	46	–	153	2.2	7901607
10	5.0	IMAGH-10	61	37	36	40	137	50	81	171	3.0	7902113

IRG – ICE-Clevis connector

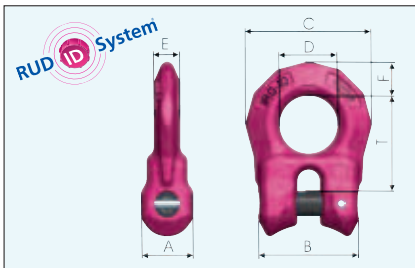

As single part for the connection of Non-RUD parts at clevis connections, flanges etc., completed with ICE-connection pin and sleeve pin, pre-assembled.

Inclusive RUD-ID-Point®.

Chain	WLL [t]	Type	A	B	C	D	E	F	T	[kg/pc.]	Ref. No.
6	1,8	IRG-6	19	34	44	21	9	12	36	0,12	7902998
8	3,0	IRG-8	24	45	56	27	12	15	43	0,25	7902999
10	5,0	IRG-10	30	56	70	32	15	19	53	0,5	7903000
13	8,0	IRG-13	38	73	88	38	18	25	67	1,0	7903001
16	12,5	IRG-16	47	90	109	48	23	31	83	2,0	7903002

ICE-oval-G-pin

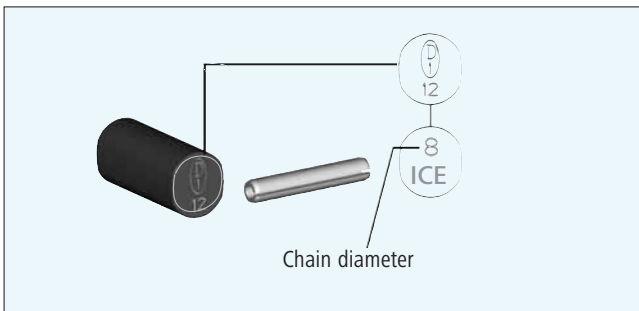

ICE-oval G-pin and retaining pin

Chain	Type	Ref. No.
6	IOG-6/Retaining pin 6	7998740
8	IOG-8/Retaining pin 8	7995739
10	IOG-10/Retaining pin 10	7995740
13	IOG-13/Retaining pin 13	7995741
16	IOG-16/Retaining pin 16	7999102*

Only available in packs of 10 (*packs of 4).

Only use original RUD-ICE parts. Design of load pin results in "Fool-proof" system compared with other RUD Grades.

ICE Identification tag

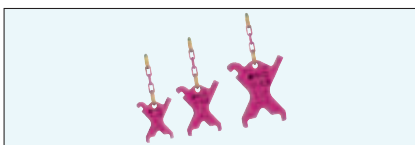

ICE Identification tag **IKZA** with integrated chain gauge

Chain	Type	1-leg	2-leg	3-/4-leg	without WLL stamping
6	IKZA-..Strg-6	7998743	7998744	7998745	7998736
8	IKZA-..Strg-8	7996286	7996287	7996288	7995552
10	IKZA-..Strg-10	7996289	7996290	7996291	7995553



Universal
(up size 13)

ICE Identification tag **IKZA** (universal size)

Chain	Type	1-leg	2-leg	3-/4-leg	Universal-KZA without WLL stamping
13	IKZA-..Strg-13	7902488	7902489	7902490	7901059
16	IKZA-..Strg-16	7902491	7902492	7902493	7901059



ICE Identification tag as a chain gauge*

Chain	Type	Ref. No.
6	IKPL-6	7998167
8	IKPL-8	7995525
10	IKPL-10	7995521
13*	IKPL-13	7995530
16*	IKPL-16	7998949

*Will be attached to each masterlink in the specific size.

RUD Lashing chain ICE-CURT with highest LC (lashing capacity)

The proven, technical advantages of the **VIP-** program have been retained and further improved. Tensioning, connecting and shortening element have been improved considerably in weight and functionality.

ICE – in ICE-Pink (traffic purple) powder coated – means significant weight saving for the user. The standard equivalent Grade 80 commercial lashing chains are on average 60 % heavier.

This improved ergonomic design, enables faster fitting and heightened safety.

It is possible to use one diameter thinner than Grade 80 <16 mm Ø.

Up to 60 % higher Lashing Capacity (LC) than Grade 80 – also up to -60°C even in Arctic applications.

All values (conditions) of EN 12195-3 are fulfilled and the essential requirements are easily exceeded. All for the health and safety of the user!

ICE-CURT

Ratchet tensioner version with an integrated fast shortener, which is assembled captive in the chain strand. As an alternative there is a clevis type available also.

Patented:

“Secured against release by a magnet blocking clutch which can be secured with a lock. Theft protection of lashing chain and transporting goods.”

Thread tube now in an open and innovative form – robust, light in weight and due to the trapezoid thread easy to clean, check and lubricate.

Made in Germany.

All pieces drop forged, quenched and tempered and 100 % crack inspected.

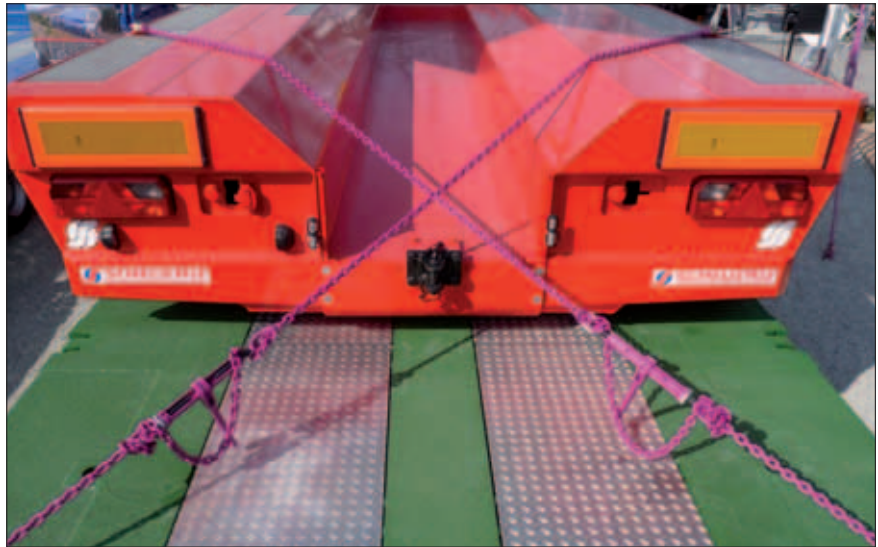

ICE sets new benchmarks in lashing chain technology!
Up to 60 % more LC-Lashing Capacity than Grade 80 – with decisive handling benefits!

Which lashing chain for which load?

Diagonal lashing													
Lashing chain	LC [daN]	Max. load weight [t] (horizontal angle β : 20°-45°; 2 lashing chains per direction)											
		Vertical angle α : 0°-30°						Vertical angle α : 30°-60°					
		$\mu=0.1$	$\mu=0.2$	$\mu=0.3$	$\mu=0.4$	$\mu=0.5$	$\mu=0.6$	$\mu=0.1$	$\mu=0.2$	$\mu=0.3$	$\mu=0.4$	$\mu=0.5$	$\mu=0.6$
ICE-VSK 6	3600	6.2	8.4	10.4	13.0	17.4	26.2	4.5	6.3	9.0	12.8	19.2	32.0
ICE-VSK 8	6000	10.5	14.0	17.4	21.8	29.1	43.9	7.6	10.7	15.0	21.4	32.0	53.4
ICE-VSK 10	10000	17.5	23.4	29.0	36.4	48.6	73.1	12.8	17.9	25.0	35.6	53.4	89.0
ICE-VSK 13	16000	28.0	37.5	46.4	58.2	77.8	117.0	20.5	28.6	40.0	57.1	85.5	142.4
ICE-VSK 16	20000	43.7	58.6	72.6	91.0	121.6	182.8	32.0	44.7	62.5	89.1	133.6	222.5

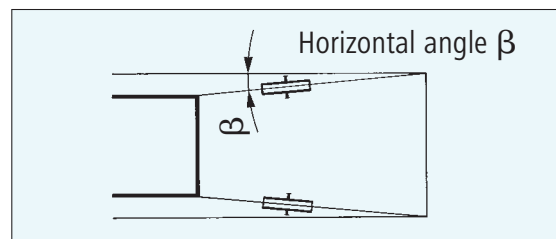
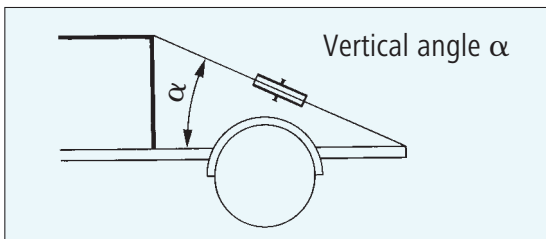

Frictional lashing													
RUD Lashing chain	STF [daN]	= required number of ICE lashing chains (number of lashing chains = factor from Table X load weight [t])											
		Vertical angle α : 60°-90°						Vertical angle α : 30°-60°					
		$\mu=0.1$	$\mu=0.2$	$\mu=0.3$	$\mu=0.4$	$\mu=0.5$	$\mu=0.6$	$\mu=0.1$	$\mu=0.2$	$\mu=0.3$	$\mu=0.4$	$\mu=0.5$	$\mu=0.6$
ICE-VSK 6	1500	3.6 x	1.6 x	0.9 x	0.6 x	0.4 x	0.2 x	6.3 x	2.7 x	1.5 x	0.9 x	0.6 x	0.3 x
ICE-VSK 8	2800	2.0 x	0.9 x	0.5 x	0.3 x	0.2 x	0.1 x	3.4 x	1.5 x	0.8 x	0.5 x	0.3 x	0.2 x
ICE-VSK 10	2800	2.0 x	0.9 x	0.5 x	0.3 x	0.2 x	0.1 x	3.4 x	1.5 x	0.8 x	0.5 x	0.3 x	0.2 x
ICE-VSK 13	2800	2.0 x	0.9 x	0.5 x	0.3 x	0.2 x	0.1 x	3.4 x	1.5 x	0.8 x	0.5 x	0.3 x	0.2 x

Values of both tables refer to: stable load. road transport. no combination with other lashing or securing methods!

Slide-coefficient of friction μ			
Materials	dry	wet	greasy
Wood/wood	0.20-0.50	0.20-0.25	0.05-0.15
Metal/wood	0.20-0.50	0.20-0.25	0.02-0.10
Metal/metal	0.10-0.25	0.10-0.20	0.01-0.10

If there is a clear deviation from the indicated lashing angles, then it is necessary to add some safety measures.

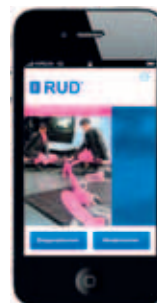

Shortly available

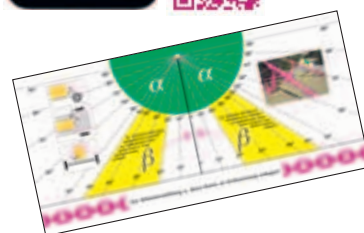

Download of the essay "Optimal load securing" under: www.rud.com

ICE-Lashig chains with ICE-CURT-Ratched spindle tensioner (vertical lashing and direct lashing)

Ratchet tensioner

Chain dia. [mm]	Type ratchet tensioner	Permissible LC	Obtainable pre-tension force	Hub [mm]	L-open [mm]	L-closed [mm]	Ref. No. Ratchet tensioner
6	ICE-CURT-6-GAKO	3600	1500	140	400	260	7903439
8	ICE-CURT-8-GAKO	6000	2800	170	520	350	7901125
10	ICE-CURT-10-GAKO	10000	2800	170	532	362	7901126
13	ICE-CURT-13-GAKO	16000	2800	300	830	530	7902624
16	ICE-CURT-16-GAKO	25000	–	350	962	612	7902625

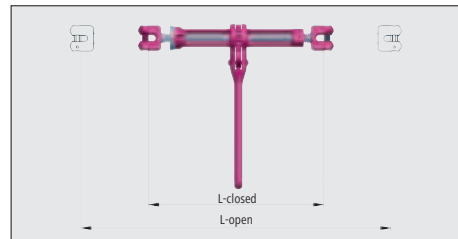

Chain dia. mm	Type lashing chain ICE-VSK-CURT-IVH	Permissible LC	Obtainable pre-tension force	L-min [mm]	Weight kgs (chain + ratchet tensioner)	Ref. No. Lashing chain
6	ICE-VSK-6-CURT-IVH	3600	1500	780	4.8 + 2.2	7903443
8	ICE-VSK-8-CURT-IVH	6000	2800	1040	8.0 + 5.2	7901129
10	ICE-VSK-10-CURT-IVH	10000	2800	1210	13.0 + 7.1	7901130
13	ICE-VSK-13-CURT-IVH	16000	2800	1600	21.9 + 13.6	7902626
16	ICE-VSK-16-CURT-IVH	25000	–	1910	34.5 + 24.3	7902627

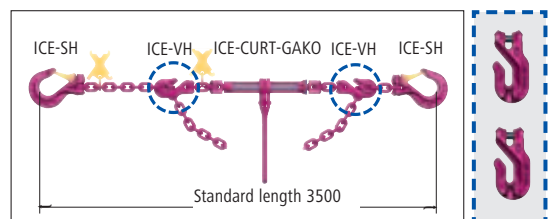

Tensioner moveable within the chain strand

Chain dia. mm	Type lashing chain ICE-VSK-CURT-IMVK	Permissible LC	Obtainable pre-tension force	L-min [mm]	Weight kgs (chain + ratchet tensioner)	Ref. No. Lashing chain
6	ICE-VSK-6-CURT-IMVK	3600	1500	770	6.3	7904614
8	ICE-VSK-8-CURT-IMVK	6000	2800	1010	11.7	7904615
10	ICE-VSK-10-CURT-IMVK	10000	2800	1170	17.0	7904616
13	ICE-VSK-13-CURT-IMVK	16000	2800	1540	28.6	7904617
16	ICE-VSK-16-CURT-IMVK	25000	–	1840	46.0	7904618

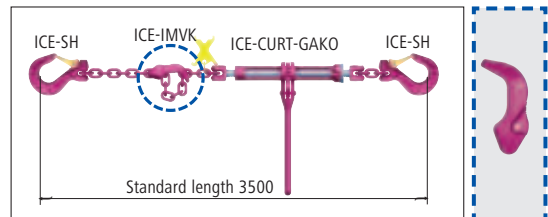

Chain dia. mm	Type lashing chain ICE-VSK-CURT-IVS	Permissible LC	Obtainable pre-tension force	L-min [mm]	Weight kgs (chain + ratchet tensioner)	Ref. No. Lashing chain
6	ICE-VSK-6-CURT-IVS	3600	1500	680	6.4	7904602
8	ICE-VSK-8-CURT-IVS	6000	2800	870	11.9	7904603
10	ICE-VSK-10-CURT-IVS	10000	2800	1000	17.7	7904604
13	ICE-VSK-13-CURT-IVS	16000	2800	1330	29.9	7904605
16	ICE-VSK-16-CURT-IVS	25000	–	1590	48.8	7904606

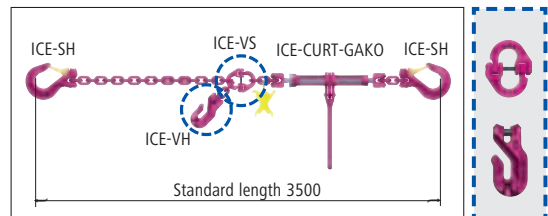

Ratchet tensioner

Chain dia. [mm]	Type ratchet tensioner	Permissible LC	Obtainable pre-tension force	Hub [mm]	L-open [mm]	L-closed [mm]	Ref. No. Ratchet tensioner
6	ICE-CURT-6-SL	3600	1500	140	470	330	7903441
8	ICE-CURT-8-SL	6000	2800	170	623	453	7999435
10	ICE-CURT-10-SL	10000	2800	170	671	501	7999436

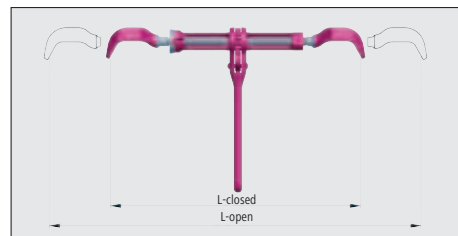

Chain dia. mm	Type lashing chain ICE-VSK-CURT-SL	Permissible LC	Obtainable pre-tension force	L-min [mm]	Weight kgs (chain + ratchet tensioner)	Ref. No. Lashing chain
6	ICE-VSK-6-CURT-SL	3600	1500	640	6.5	7903444
8	ICE-VSK-8-CURT-SL	6000	2800	817	12.6	7900026
10	ICE-VSK-10-CURT-SL	10000	2800	935	18.1	7900027

Captive tensioner moveable within the chain strand

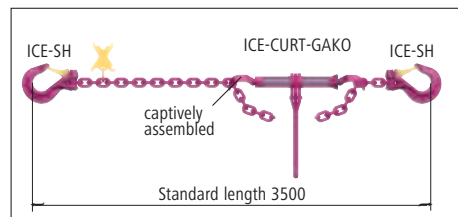

ICE-Lashing chains with ICE-CURT-K – Bar spindle tensioner (direct lashing only)

Tensioner with locking handle

Chain dia. [mm]	Type Bar spindle tensioner	Permissible LC	Obtainable pre-tension force	Hub [mm]	L-open [mm]	L-closed [mm]	Ref. No. Tensioner with locking handle
6	ICE-CURT-K-6-GAKO	3600	direct lashing only	140	400	260	7904448
8	ICE-CURT-K-8-GAKO	6000	direct lashing only	170	520	350	7904449
10	ICE-CURT-K-10-GAKO	10000	direct lashing only	170	532	362	7904450
13	ICE-CURT-K-13-GAKO	16000	direct lashing only	300	830	530	7904451
16	ICE-CURT-K-16-GAKO	25000	direct lashing only	350	962	612	7904452

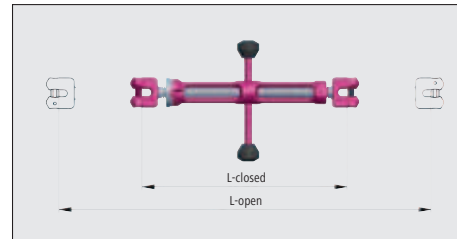

Chain dia. mm	Type lashing chain ICE-VSK-CURT-IVH	Permissible LC	Obtainable pre-tension force	L-min [mm]	Weight kgs (chain + Bar spindle tensioner)	Ref. No. Lashing chain
6	ICE-VSK-6-CURT-K-IVH	3600	direct lashing only	780	4.8 + 2.5	7904493
8	ICE-VSK-8-CURT-K-IVH	6000	direct lashing only	1040	8.0 + 4.5	7904494
10	ICE-VSK-10-CURT-K-IVH	10000	direct lashing only	1210	13.0 + 6.4	7904495
13	ICE-VSK-13-CURT-K-IVH	16000	direct lashing only	1600	21.9 + 12.6	7904496
16	ICE-VSK-16-CURT-K-IVH	25000	direct lashing only	1910	34.5 + 23.2	7904497

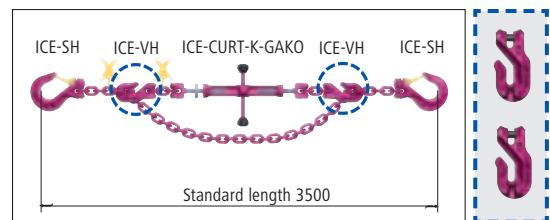

Tensioner moveable within the chain strand

Chain dia. mm	Type lashing chain ICE-VSK-CURT-IMVK	Permissible LC	Obtainable pre-tension force	L-min [mm]	Weight kgs (chain + Bar spindle tensioner)	Ref. No. Lashing chain
6	ICE-VSK-6-CURT-K-IMVK	3600	direct lashing only	770	6.6	7904608
8	ICE-VSK-8-CURT-K-IMVK	6000	direct lashing only	1010	11.0	7904610
10	ICE-VSK-10-CURT-K-IMVK	10000	direct lashing only	1170	16.3	7904611
13	ICE-VSK-13-CURT-K-IMVK	16000	direct lashing only	1540	27.6	7904612
16	ICE-VSK-16-CURT-K-IMVK	25000	direct lashing only	1840	44.9	7904613

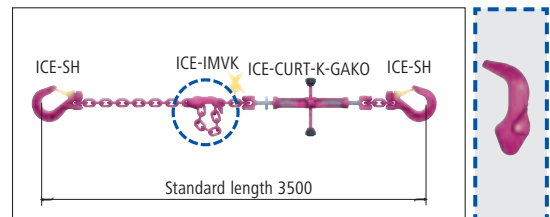

Chain dia. mm	Type lashing chain ICE-VSK-CURT-IVS	Permissible LC	Obtainable pre-tension force	L-min [mm]	Weight kgs (chain + Bar spindle tensioner)	Ref. No. Lashing chain
6	ICE-VSK-6-CURT-K-IVS	3600	direct lashing only	680	6.7	7904596
8	ICE-VSK-8-CURT-K-IVS	6000	direct lashing only	870	11.2	7904598
10	ICE-VSK-10-CURT-K-IVS	10000	direct lashing only	1000	17.0	7904599
13	ICE-VSK-13-CURT-K-IVS	16000	direct lashing only	1330	28.9	7904600
16	ICE-VSK-16-CURT-K-IVS	25000	direct lashing only	1590	47.7	7904601

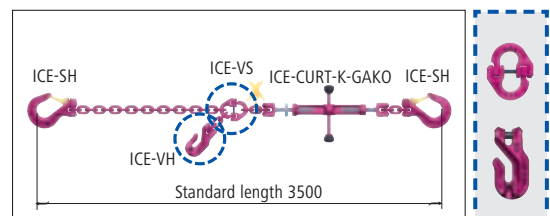

Tensioner with locking handle

Chain dia. [mm]	Type tensioner with locking handle	Permissible LC	Obtainable pre-tension force	Hub [mm]	L-open [mm]	L-closed [mm]	Ref. No. (chain + Bar spindle tensioner)
6	ICE-CURT-K-6-SL	3600	direct lashing only	140	470	330	7904453
8	ICE-CURT-K-8-SL	6000	direct lashing only	170	623	453	7994454
10	ICE-CURT-K-10-SL	10000	direct lashing only	170	671	501	7994455

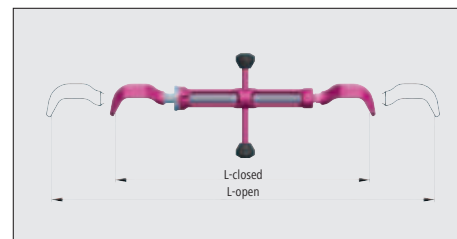

Chain dia. mm	Type lashing chain ICE-VSK-CURT-SL	Permissible LC	Obtainable pre-tension force	L-min [mm]	Weight kgs (chain + Bar spindle tensioner)	Ref. No. Lashing chain
6	ICE-VSK-6-CURT-K-SL	3600	direct lashing only	640	6.8	7904498
8	ICE-VSK-8-CURT-K-SL	6000	direct lashing only	817	11.7	7904499
10	ICE-VSK-10-CURT-K-SL	10000	direct lashing only	935	17.3	7904500

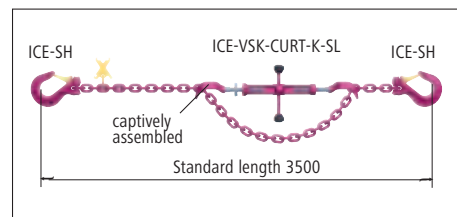

Captive tensioner moveable within the chain strand

RUD-Quality in PIN



Grade 80, Grade 100 (VIP) and Grade 120 (ICE) »in metric tons« of sling
According to inclination angle at symmetrical load

RUD quality grades

80

100 %

100

133 %

120

160 %

WLL

Grade **80** **VIP 100** **ICE 120**



RUD ID System		1-leg		2-leg		3-4 leg			
		Methods of sling							
inclination angle: β		0		0-45°	> 45-60°	0-45°	> 45-60°		
load factor		1.0		1.4	1.0	2.1	1.5		
Diam. of chains	Quality grade								
Ø 4	VIP	0.63	0.88	0.63	1.32	0.95			
	ICE	0.80	1.12	0.80	1.70	1.18			
Ø 6	Grade 80	1.12	1.6	1.12	2.36	1.7			
	VIP	1.5	2.1	1.5	3.15	2.25			
	ICE	1.8	2.5	1.8	3.75	2.7			
Ø 8	Grade 80	2.0	2.8	2.0	4.25	3.0			
	VIP	2.5	3.5	2.5	5.25	3.75			
	ICE	3.0	4.25	3.0	6.3	4.5			
Ø 10	Grade 80	3.15	4.25	3.15	6.7	4.75			
	VIP	4.0	5.6	4.0	8.4	6.0			
	ICE	5.0	7.0	5.0	10.5	7.5			
Ø 13	Grade 80	5.3	7.5	5.3	11.2	8.0			
	VIP	6.7	9.5	6.7	14.0	10.0			
	ICE	8.0	11.2	8.0	17.0	11.8			
Ø 16	Grade 80	8.0	11.2	8.0	17.0	11.8			
	VIP	10.0	14.0	10.0	21.2	15.0			
	ICE	12.5	17.0	12.5	26.5	19.0			
Ø 18	Grade 80	10.0	14.0	10.0	21.2	15.0			
Ø 20	Grade 80	12.5	17.0	12.5	26.5	19.0			
	VIP	16.0	22.4	16.0	33.6	24.0			
Ø 22	Grade 80	15.0	21.2	15.0	31.5	22.4			
	VIP	20.0	28.0	20.0	42.0	30.0			
Ø 26	Grade 80	21.2	30.0	21.2	45.0	31.5			
Ø 28	VIP	31.5	45.0	31.5	67.0*	47.5*			
Ø 32	Grade 80	31.5	45.0	31.5	67.0	47.5			

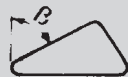

Attention:

Acc. to BGR 500 section 2.8, the WLL for single fall becomes valid when unsymmetrical load occurs at a multiple strand sling.

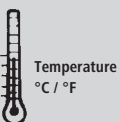

Subject to technical modifications! *Only 2 x 2-leg type available.

K!

Grade 120 (ICE) Basket chains Metric loading



endless** Basket sling chain with choke hitch	Basket sling chain**				Choke hitch**		
	single		double		single	double	
	0-45°	> 45-60°	0-45°	> 45-60°	0	0-45°	> 45-60°
1.6	1.1	0.8	1.7	1.2	0.8	1.1	0.8
1.0	0.69	0.5	1.1	0.75	0.5	0.69	0.5
1.25	0.88	0.64	1.36	0.96	0.64	0.88	0.64
1.8	1.2	0.9	1.9	1.3	0.9	1.2	0.9
2.4	1.65	1.2	2.55	1.8	1.2	1.65	1.2
2.88	2.0	1.44	3.1	2.1	1.44	2.0	1.44
3.2	2.2	1.6	3.4	2.4	1.6	2.2	1.6
4.0	2.75	2.0	4.25	3.0	2.0	2.75	2.0
4.8	3.3	2.4	5.1	3.6	2.4	3.3	2.4
5.0	3.5	2.5	5.3	3.8	2.5	3.5	2.5
6.4	4.4	3.2	6.8	4.8	3.2	4.4	3.2
8.0	5.5	4.0	8.5	6.0	4.0	5.5	4.0
8.5	5.8	4.0	9.0	6.0	4.0	5.8	4.0
10.6	7.5	5.3	11.2	8.0	5.3	7.5	5.3
12.5	8.8	6.4	13.6	9.6	6.4	8.8	6.4
12.5	8.8	6.4	13.6	9.6	6.4	8.8	6.4
16.0	11.0	8.0	17.0	12.0	8.0	11.0	8.0
20.0	14.0	10.0	21.2	15.0	10.0	14.0	10.0
16.0	11.0	8.0	17.0	12.0	8.0	11.0	8.0
20.0	14.0	10.0	21.2	15.0	10.0	14.0	10.0
25.6	17.6	12.8	27.2	19.2	12.8	17.6	12.8
23.6	16.5	12.0	25.5	18.0	12.0	16.5	12.0
32.0	22.0	16.0	34.0	24.0	16.0	22.0	16.0
33.5	23.3	17.0	36.0	25.4	17.0	23.0	17.0
50.0	35.5	25.0	53.0*	37.5*	25.0	35.5	25.0
50.0	35.5	25.0	53.0	37.5	25.0	35.5	25.0
Grade 80	-40° up to +200° C (+40° up to +392° F)	higher 200° up to 300° C (higher 392° up to 572° F)	higher 300° up to 400° C (higher 572° up to 752° F)	**20 % reduction for basket chains, due to sharp edges, is considered.			
	100 %	90 %	75 %				
VIP 100	-40° up to +200° C (+40° up to +392° F)	higher 200° up to 300° C (higher 392° up to 572° F)	higher 300° up to 380° C (higher 572° up to 716° F)				
	100 %	90 %	60 %				
ICE 120	-60° up to +200° C (-76° up to +392° F)	higher 200° up to 250° C (higher 392° up to 482° F)	higher 250° up to 300° C (higher 482° up to 572° F)				
	100 %	90 %	60 %				

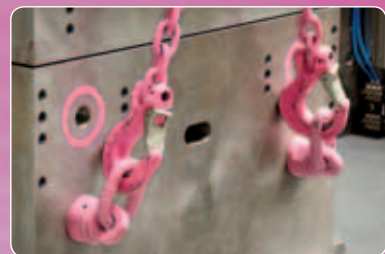

RUD Ketten
Rieger & Dietz GmbH u. Co. KG
Friedensinsel
73432 Aalen/Germany
Tel.: +49 7361 504-1316-1370-1224
Fax: +49 7361 504-1460
sling@rud.com · www.rud.com



The suitable range of modern and safe Lifting Points – for bolting

Thread sizes M 6- M 150 Imperial (UNC....) and special lengths on request		PP-S (Vario) PowerPoint-Star			PP-B (Vario) PowerPoint-B			PP-VIP (Vario) PowerPoint-VIP		VLBG Load Ring (Vario)															
		Number of legs Load direction		Typ	PP-S 0.63 t	PP-S 1.5 t	PP-S 2.5 t	PP-S 4 t	PP-S 5 t	PP-S 8 t	VLBG 0.3 t	VLBG 0.63 t	VLBG 1 t	VLBG 1.5 t	VLBG 2.5 t	VLBG 4 t	VLBG 4 t	VLBG 5 t	VLBG 7 t Sond.	VLBG 8 t	VLBG 10 t	VLBG 15 t	VLBG 20 t	VLBG (3) M16 RS 1t	VLBG (3) M20 RS 2t
		Thread size		M	M	M	M	M	M	M	M	M	M	M	M	M	M	M	M	M	M	M	M	M	M
	1 0°			0.6	1.5	2.5	4	6.7	10	0.3	0.6	1	1.5	2.5	4	4	5	7	8	10	15	20	1	2	
	2 0°			1.2	3	5	8	13.4	20	0.6	1.2	2	3	5	8	8	10	14	16	20	30	40	2	4	
	1 90°			0.6	1.5	2.5	4	5	8	0.3	0.6	1	1.5	2.5	4	4	5	7	8	10	15	20	1	2	
	2 90°			1.2	3	5	8	10	16	0.6	1.2	2	3	5	8	8	10	14	16	20	30	40	2	4	
	2 0-45°			0.8	2.1	3.5	5.6	7.1	11.2	0.4	0.8	1.4	2.1	3.5	5.6	5.6	7	9.8	11.2	14	21	28	1.4	2.8	
	2 45-60°			0.6	1.5	2.5	4	5	8	0.3	0.6	1	1.5	2.5	4	4	5	7	8	10	15	20	1	2	
	2 unsymmetrical			0.6	1.5	2.5	4	5	8	0.3	0.6	1	1.5	2.5	4	4	5	7	8	10	15	20	1	2	
	3+4 0-45°			1.3	3.2	5.3	8.4	10.5	16.8	0.6	1.3	2.1	3.1	5.2	8.4	8.4	10.5	14.7	16.8	21	31.5	42	2.1	4.2	
	3+4 45-60°			0.9	2.2	3.8	6	7.5	12	0.4	0.9	1.5	2.2	3.7	6	6	7.5	10.4	12	15	22.5	30	1.5	3	
	3+4 unsymmetrical			0.6	1.5	2.5	4	5	8	0.3	0.6	1	1.5	2.5	4	4	5	7	8	10	15	20	1	2	
		Thread size		M	M	M	M	M	M	M	M	M	M	M	M	M	M	M	M	M	M	M	M	M	
				12	16	20	24	30	36	8	10	12	16	20	24	27	30	36	36	42	42	48	16	20	

Stain-
less

Maximum transport weight "G" in [tonnes] with different lifting methods

- All parts are either 100 % crack detected or proof loaded accord. to EN 1677.
- All original bolts from RUD are 100 % crack detected.
- Safety factor 4:1 in any direction.
- The types VRS, VRM, INOX-STAR and VLBG have to be adjusted to the load direction.
- Low installation height, high dynamic and static strength.
- RUD features such as clamping spring (VLBS) for noise reduction and distance lugs for a perfect root pass weld increase the ease of use.



The suitable range of modern and safe Lifting Points – for bolting

VWBG-V Load Ring (Vario)											VWBG Load Ring																		
VWBG-V 0.3 t	VWBG-V 0.45 t	VWBG-V 0.6 t	VWBG-V 1.0 t	VWBG-V 1.3 t	VWBG-V 1.8 t	VWBG-V 2 t	VWBG-V 2 t	VWBG-V 3.5 t	VWBG-V 3.5 t	VWBG-V 5 t	VWBG 6 (7.5)	VWBG 8 (10)	VWBG 8 (10)	VWBG 12 (13)	VWBG 12 (13)	VWBG 12 (15)	VWBG 13 (16)	VWBG 13 (16)	VWBG 14 (20)	VWBG 16 (22)	VWBG 16 (22)	VWBG 16 (25)	VWBG 16 (25)	VWBG 31.5 (40)	VWBG 31.5 (40)	VWBG 35 (48)	VWBG 35 (48)	VWBG 40 (50)	VWBG 40 (50)
M 8	M 10	M 12	M 14	M 16	M 18	M 20	M 22	M 24	M 27	M 30	M 33	M 36	M 36-39	M 42	M 42-45	M 45	M 48	M 48-52	M 52	M 56	M 56-62	M 64	M 64-76	M 72	M 72-76	M 80	M 80-85	M 90	M 90-150
0.6	0.9	1.2	2	2.6	3.6	4	4	7	7	10	15	15	15	17	17	18	18	18	25	28	28	28	28	50	50	50	50	50	50
1.2	1.8	2.4	4	5.2	7.2	8	8	14	14	20	30	30	30	34	34	36	36	36	50	56	56	56	56	100	100	100	100	100	100
0.3 (0.4)	0.45 (0.6)	0.6 (0.7)	1 (1.25)	1.3 (1.5)	1.8 (2)	2 (2.5)	2 (2.5)	3.5 (4)	3.5 (4)	5 (6)	6 (7.5)	8 (10)	8 (10)	12 (13)	12 (13)	12 (15)	13 (16)	13 (16)	14 (20)	16 (22)	16 (22)	16 (25)	16 (25)	31.5 (40)	31.5 (40)	35 (48)	35 (48)	40 (50)	40 (50)
0.6 (0.8)	0.9 (1.2)	1.2 (1.5)	2 (2.5)	2.6 (3)	3.6 (4)	4 (5)	4 (5)	7 (8)	7 (8)	10 (12)	12 (15)	16 (20)	16 (20)	24 (26)	24 (26)	24 (30)	26 (32)	26 (32)	28 (40)	32 (44)	32 (44)	32 (50)	32 (50)	63 (80)	63 (80)	70 (96)	70 (96)	80 (100)	80 (100)
0.4 (0.56)	0.6 (0.84)	0.8 (1.05)	1.4 (1.75)	1.8 (2.1)	2.5 (2.8)	2.8 (3.5)	2.8 (3.5)	4.9 (5.6)	4.9 (5.6)	7 (8.4)	8.4 (10.5)	11.2 (14)	11.2 (14)	16.8 (18.2)	16.8 (18.2)	16.8 (21)	18.2 (22.4)	18.2 (22.4)	19.6 (28)	22.4 (30.8)	22.4 (30.8)	22.4 (35)	22.4 (35)	44.1 (56)	44.1 (56)	49 (67.2)	49 (67.2)	56 (70)	56 (70)
0.3 (0.4)	0.45 (0.6)	0.6 (0.7)	1 (1.25)	1.3 (1.5)	1.8 (2)	2 (2.5)	2 (2.5)	3.5 (4)	3.5 (4)	5 (6)	6 (7.5)	8 (10)	8 (10)	12 (13)	12 (13)	12 (15)	13 (16)	13 (16)	14 (20)	16 (22)	16 (22)	16 (25)	16 (25)	31.5 (40)	31.5 (40)	35 (48)	35 (48)	40 (50)	40 (50)
0.3 (0.4)	0.4 (0.6)	0.6 (0.7)	1 (1.25)	1.3 (1.5)	1.8 (2)	2 (2.5)	2 (2.5)	3.5 (4)	3.5 (4)	5 (6)	6 (7.5)	8 (10)	8 (10)	12 (13)	12 (13)	12 (15)	13 (16)	13 (16)	14 (20)	16 (22)	16 (22)	16 (25)	16 (25)	31.5 (40)	31.5 (40)	35 (48)	35 (48)	40 (50)	40 (50)
0.6 (0.84)	0.9 (1.26)	1.2 (1.58)	2.1 (2.62)	2.7 (3.15)	3.7 (4.2)	4.2 (5.25)	4.2 (5.25)	7.3 (8.4)	7.3 (8.4)	10.5 (12.6)	12.6 (15.7)	16.8 (21)	16.8 (21)	25.2 (27.3)	25.2 (27.3)	25.2 (31.5)	27.3 (33.6)	27.3 (33.6)	29.4 (42)	33.6 (46.2)	33.6 (46.2)	33.6 (52.5)	33.6 (52.5)	66.15 (84)	66.15 (84)	73.5 (100)	73.5 (100)	84 (105)	84 (105)
0.4 (0.6)	0.6 (0.9)	0.9 (1.12)	1.5 (1.87)	1.9 (2.25)	2.7 (3)	3 (3.75)	3 (3.75)	5.2 (6)	5.2 (6)	7.5 (9)	9 (11.2)	12 (15)	12 (15)	18 (19.5)	18 (19.5)	18 (22.5)	19.5 (24)	19.5 (24)	21 (30)	24 (33)	24 (33)	24 (37.5)	24 (37.5)	47.25 (60)	47.25 (60)	52.5 (72)	52.5 (72)	60 (75)	60 (75)
0.3 (0.4)	0.4 (0.6)	0.6 (0.7)	1 (1.25)	1.3 (1.5)	1.8 (2)	2 (2.5)	2 (2.5)	3.5 (4)	3.5 (4)	5 (6)	6 (7.5)	8 (10)	8 (10)	12 (13)	12 (13)	12 (15)	13 (16)	13 (16)	14 (20)	16 (22)	16 (22)	16 (25)	16 (25)	31.5 (40)	31.5 (40)	35 (48)	35 (48)	40 (50)	40 (50)
M 8	M 10	M 12	M 14	M 16	M 18	M 20	M 22	M 24	M 27	M 30	M 33	M 36	M 36-39	M 42	M 42-45	M 45	M 48	M 48-52	M 52	M 56	M 56-60	M 64	M 64-76	M 72	M 72-76	M 80	M 80-85	M 90	M 90-150

Maximum transport weight "G" in [tonnes] with different lifting methods

■ RUD Lifting Point CD-ROM makes it easy to select the right Lifting Point.

■ RUD Lifting Points conform fully dynamic applications of 20000 load cycles, with 50 % overload.

■ In case of higher dynamic application please ask manufacturer.



The suitable range of modern and safe Lifting Points – for bolting

Thread sizes M 6- M 150 Imperial (UNC....) and special lengths on request		Starpoint VRS (Vario) eyebolt		Starpoint VRM eyebolt		INOX-STAR		RS & RM High-tensile eyebolt / eye nut		VRBG Load Ring																																																																																																																																		
Number of legs	Load direction	Thread size																																																																																																																																										
		Typ			VRS M6 / VRM M6			VRS M8 / VRM M8			VRS M10 / VRM M10			VRS M12 / VRM M12			VRS M16 / VRM M16			VRS M20 / VRM M20			VRS M24 / VRM M24			VRS M30 / VRM M30			VRS M36			VRS M42			VRS M48			INOX M12			INOX M16			INOX M20			INOX M24			INOX M30			RS M6 / RM M6			RS M8 / RM M8			RS M10 / RM M10			RS M12 / RM M12			RS M14 / RM M14			RS M16 / RM M16			RS M20 / RM M20			RS M24 / RM M24			RS M30 / RM M30			RS M36 / RM M36			RS M42 / RM M42			RS M48 / RM M48			VRBG 3 t		VRBG 10 t		VRBG 16 t		VRBG 31.5 t		VRBG 50 t		WBPG 80 t		WBPG 100 t		WBPG 200 t																																					
Thread size	Typ	M 6	M 8	M 10	M 12	M 16	M 20	M 24	M 30	M 36	M 42	M 48	M 12	M 16	M 20	M 24	M 30	M 6	M 8	M 10	M 12	M 14	M 16	M 20	M 24	M 30	M 36	M 42	M 48	M 12	M 16	M 20	M 24	M 30	M 6	M 8	M 10	M 12	M 14	M 16	M 20	M 24	M 30	M 36	M 42	M 48	2x	4x	4x	6x	8x	6x	6x	10x	16	20	30	30	36	48	48	3	10	16	31.5	50	85	100	200	6	20	32	63	100	170	200	400	4.2	14	22.4	45	70	119	140	280	3	10	16	31.5	50	85	100	200	3	10	16	31.5	50	85	100	200	6.3	21	33.6	67	105	178	210	420	4.5	15	24	47.5	75	127	150	300	3	10	16	31.5	50	85	100	200	2x	4x	4x	6x	8x	6x	6x	10x	16	20	30	30	36	48	48
	1 0°	0.5	1	1	2	4	6	8	12	16	24	32	1.2	2.4	3.6	5.2	-	0.4	0.8	1	1.6	3	4	6	8	12	16	24	32	3	10	16	31.5	50	85	100	200	<p>We recommend to use »VRS-Starpoint!« which can be adjusted to the direction of pull!</p>																																																																																																						
	2 0°	1	2	2	4	8	12	16	24	32	48	64	2.4	4.8	7.2	10.4	-	0.8	1.6	2	3.2	6	8	12	16	24	32	48	64	6	20	32	63	100	170	200	400																																																																																																							
	1 90°	0.1	0.3	0.4	0.7	1.5	2.3	3.2	4.5	7	9	12	0.5	1	2	2.5	-													3	10	16	31.5	50	85	100	200																																																																																																							
	2 90°	0.2	0.6	0.8	1.5	3	4.6	6.4	9	14	18	24	1	2	4	5	-													6	20	32	63	100	170	200	400																																																																																																							
	2 0-45°	0.14	0.42	0.56	1	2.1	3.2	4.5	6.3	9.8	12.6	16.8	0.7	1.4	2.8	3.5	-													4.2	14	22.4	45	70	119	140	280																																																																																																							
	2 45-60°	0.1	0.3	0.4	0.7	1.5	2.3	3.2	4.5	7	9	12	0.5	1	2	2.5	-													3	10	16	31.5	50	85	100	200																																																																																																							
	2 unsymmetrical	0.1	0.3	0.4	0.7	1.5	2.3	3.2	4.5	7	9	12	0.5	1.0	2.0	2.5	-													3	10	16	31.5	50	85	100	200																																																																																																							
	3+4 0-45°	0.21	0.63	0.8	1.5	3.1	4.8	6.7	9.4	14.7	18.9	25	1	2.1	4.2	5.3	-													6.3	21	33.6	67	105	178	210	420																																																																																																							
	3+4 45-60°	0.15	0.45	0.6	1.1	2.2	3.4	4.8	6.7	10.5	13.5	18	0.7	1.5	3	3.7	-													4.5	15	24	47.5	75	127	150	300																																																																																																							
	3+4 unsymmetrical	0.1	0.3	0.4	0.7	1.5	2.3	3.2	4.5	7	9	12	0.5	1	2	2.5	-													3	10	16	31.5	50	85	100	200																																																																																																							

Maximum transport weight "G" in [tonnes] with different lifting methods

* The WLL values of the VRM are only valid with threaded bolts of quality 10.9.



The suitable product line of modern and safe lifting – and lashing points – weldable

	PowerPoint WPP-series / WPPH-series rotation / fixed		VLBS Load ring for welding (LPW in daN for lashing)						VRBS-FIX (LRBS-FIX in daN for lashing)						VRBK-FIX Eye Plate for corners 90° (LRBK-FIX in daN for lashing)			ABA (L-ABA in daN for lashing)														
	all variations	Stain- less	3000 daN		5000 daN		8000 daN		13400 daN		20000 daN		8000 daN		13400 daN		20000 daN		3200 daN		6400 daN		10000 daN		20000 daN							
Number of legs	Load direction	WPP / WPPH 0.63 t	WPP / WPPH 1.5 t	WPP / WPPH 2.5 t	WPP / WPPH 4 t	WPP / WPPH 5 t	WPP / WPPH 8 t	VLBS 1.5 t	VLBS 2.5 t	VLBS 4 t	VLBS 6.7 t	VLBS 10 t	VLBS 16 t	LBS(1) RS 0.5 t	LBS(3) RS 1 t	LBS(5) RS 2 t	VRBS-FIX 4 t	VRBS-FIX 6.7 t	VRBS-FIX 10 t	VRBS-FIX 16 t	VRBS-FIX 31.5 t	VRBS 50 t	VRBK-FIX 4 t	VRBK-FIX 6.7 t	VRBK-FIX 10 t	ABA 1.6 t	ABA 3.2 t	ABA 5 t	ABA 10 t	ABA 20 t	ABA 31.5 t	
	1 0°	0.6	1.5	2.5	4	6.7	10	1.5	2.5	4	6.7	10	16	0.5	1	2	4	6.7	10	16	31.5	50	4	6.7	10	1.6	3.2	5	10	20	31.5	
	2 0°	1.2	3	5	8	13.4	20	3	5	8	13.4	20	32	1	2	4	8	13.4	20	32	63	100	8	13.4	20	3.2	6.4	10	20	40	63	
	1 90°	0.6	1.5	2.5	4	5	8	1.5	2.5	4	6.7	10	16	0.5	1	2	4	6.7	10	16	31.5	50	4	6.7	10	1.6	3.2	5	10	20	31.5	
	2 90°	1.2	3	5	8	10	16	3	5	8	13.4	20	32	1	2	4	8	13.4	20	32	63	100	8	13.4	20	3.2	6.4	10	20	40	63	
	2 0-45°	0.8	2.1	3.5	5.6	7.1	11.2	2.1	3.5	5.6	9.38	14	22.4	0.7	1.4	2.8	5.6	9.38	14	22.4	45	70	5.6	9.38	14	2.2	4.5	7.1	14.1	28	45	
	2 45-60°	0.6	1.5	2.5	4	5	8	1.5	2.5	4	6.7	10	16	0.5	1	2	4	6.7	10	16	31.5	50	4	6.7	10	1.6	3.2	5	10	20	31.5	
	2 unsymmetrical	0.6	1.5	2.5	4	5	8	1.5	2.5	4	6.7	10	16	0.5	1	2	4	6.7	10	16	31.5	50	4	6.7	10	1.6	3.2	5	10	20	31.5	
	3+4 0-45°	1.3	3.2	5.3	8.4	10.5	16.8	3.15	5.25	8.4	14.1	21	33.6	1.05	2.1	4.2	8.4	14.1	21	33.6	67	105	8.4	14.1	21	3.4	6.8	10.6	21.2	42	67	
	3+4 45-60°	0.9	2.2	3.8	6	7.5	12	2.25	3.75	6	10.1	15	24	0.75	1.5	3	6	10.1	15	24	47.5	75	6	10.1	15	2.4	4.8	7.5	15	30	47.5	
	3+4 unsymmetrical	0.6	1.5	2.5	4	5	8	1.5	2.5	4	6.7	10	16	0.5	1	2	4	6.7	10	16	31.5	50	4	6.7	10	1.6	3.2	5	10	20	31.5	
Weld		Δ	Δ	HY	HY	HY	HY	HV	HV	HV	HV	HV	HV	HV	HV	HV	HY	HY	HY	HY	HY	HY	HY	HY	HY	HY	Δ	Δ	Δ	Δ	Δ	Δ
		3.5	4.5	3+5	3+6	3+8	3+10	5+3	7+3	8+3	12+4	16+4	25+6	5+3	8+3	12+4	3	5	6	9	12	25+8	3+4	3+5	8+3	4	6	7	8	12	15	

Maximum transport weight "G" in [tonnes] with different lifting methods

RUD Ketten
 Rieger & Dietz GmbH u. Co. KG
 Friedensinsel
 73432 Aalen/Germany
 Telefon +49 7361 504-1371
 Telefax +49 7361 504-1460
 sling@rud.com
 www.rud.com

Lifting chain poster,
 for RUD
 chains of Grade 80,
 VIP and ICE.

RUD-Quality in PINK!

Grade 80, Grade 100 (VIP) and Grade 120 (ICE)

WLL »in metric tons« of sling chains

According to inclination angle at symmetric loading

RUD quality grades

80 **100** **120**

100% 133% 160%

WLL

Grade 80 **VIP** **ICE**

8 10 12

ICE-VH ICE-MVK

ICE-Star Hook ICE-AGH

H-Connector ICE-CURT

RUD ID System

Methods of sling

Inclination angle: β	1-leg		2-leg		3-4 leg		endless** load ring chain with side link		Basket sling chain**		Choke hitch**			
	single	double	single	double	single	double	single	double	single	double	single	double		
0	1.0	1.4	1.0	2.1	1.5	1.5	1.6	1.1	0.8	1.7	1.2	0.8	1.1	0.8
0-45°	0.63	0.88	0.63	1.32	0.95	1.0	0.63	0.5	1.1	1.75	1.2	0.63	0.88	0.64
> 45-60°	0.80	1.12	0.80	1.70	1.18	1.25	0.88	0.64	1.36	0.96	0.64	0.88	0.64	0.64

Ø	Quality grade	Inclination angle: β												
		0	0-45°	> 45-60°	0-45°	> 45-60°	-	0-45°	> 45-60°	0-45°	> 45-60°	0	0-45°	> 45-60°
Ø 4	Grade 80	1.12	1.6	1.12	2.36	1.7	1.8	1.2	0.9	1.9	1.3	0.9	1.2	0.9
	VIP	1.5	2.1	1.5	3.15	2.25	2.4	1.65	1.2	2.55	1.8	1.2	1.65	1.2
	ICE	1.8	2.5	1.8	3.75	2.7	2.88	2.0	1.44	3.1	2.1	1.44	2.0	1.44
Ø 6	Grade 80	2.0	2.8	2.0	4.25	3.0	3.2	2.2	1.6	3.4	2.4	1.6	2.2	1.6
	VIP	2.5	3.5	2.5	3.75	3.75	4.0	2.75	2.0	4.25	3.0	2.0	2.75	2.0
	ICE	3.0	4.25	3.0	6.3	4.5	4.8	3.3	2.4	5.1	3.6	2.4	3.3	2.4
Ø 8	Grade 80	3.15	4.25	3.15	6.7	4.75	5.0	3.5	2.5	5.3	3.8	2.5	3.5	2.5
	VIP	4.0	5.6	4.0	8.4	6.0	6.4	4.4	3.2	6.8	4.8	3.2	4.4	3.2
	ICE	5.0	7.0	5.0	10.5	7.5	8.0	5.5	4.0	8.5	6.0	4.0	5.5	4.0
Ø 10	Grade 80	5.3	7.5	5.3	11.2	8.0	8.5	5.8	4.0	9.0	6.0	4.0	5.8	4.0
	VIP	6.7	9.5	6.7	14.0	10.0	10.6	7.5	5.3	11.2	8.0	5.3	7.5	5.3
	ICE	8.0	11.2	8.0	17.0	11.8	12.5	8.4	6.4	13.6	9.6	6.4	8.4	6.4
Ø 13	Grade 80	8.0	11.2	8.0	17.0	11.8	12.5	8.8	6.4	13.6	9.6	6.4	8.8	6.4
	VIP	10.0	14.0	10.0	21.2	15.0	16.0	11.0	8.0	17.0	12.0	8.0	11.0	8.0
	ICE	12.5	17.0	12.5	26.5	19.0	20.0	14.0	10.0	21.2	15.0	10.0	14.0	10.0
Ø 16	Grade 80	10.0	14.0	10.0	21.2	15.0	16.0	11.0	8.0	17.0	12.0	8.0	11.0	8.0
	VIP	12.5	17.0	12.5	26.5	19.0	20.0	14.0	10.0	21.2	15.0	10.0	14.0	10.0
	ICE	15.0	21.2	15.0	31.5	22.4	23.6	16.5	12.0	25.5	18.0	12.0	16.5	12.0
Ø 18	Grade 80	12.5	17.0	12.5	26.5	19.0	20.0	14.0	10.0	21.2	15.0	10.0	14.0	10.0
	VIP	16.0	22.4	16.0	33.6	24.0	25.6	17.8	12.8	27.2	19.2	12.8	17.6	12.8
	ICE	20.0	28.0	20.0	42.0	30.0	32.0	22.0	16.0	34.0	24.0	16.0	22.0	16.0
Ø 20	Grade 80	15.0	21.2	15.0	31.5	22.4	23.6	16.5	12.0	25.5	18.0	12.0	16.5	12.0
	VIP	20.0	28.0	20.0	42.0	30.0	32.0	22.0	16.0	34.0	24.0	16.0	22.0	16.0
	ICE	25.0	35.0	25.0	52.5	37.5	40.0	28.5	20.0	42.5	30.0	20.0	28.5	20.0
Ø 22	Grade 80	17.0	23.8	17.0	35.7	25.2	26.4	18.0	13.0	27.0	19.0	13.0	18.0	13.0
	VIP	22.0	31.0	22.0	46.2	33.0	34.8	24.0	17.0	35.0	25.0	17.0	24.0	17.0
	ICE	27.0	37.0	27.0	55.5	39.0	40.8	28.5	20.0	42.5	30.0	20.0	28.5	20.0
Ø 26	Grade 80	21.2	30.0	21.2	45.0	31.5	33.5	23.3	17.0	36.0	25.4	17.0	23.0	17.0
	VIP	27.5	37.5	27.5	56.25	39.375	41.625	29.625	21.25	45.0	31.25	21.25	29.625	21.25
	ICE	33.75	46.875	33.75	70.3125	50.625	53.4375	37.125	26.625	56.25	39.0625	26.625	37.125	26.625
Ø 28	Grade 80	23.8	33.6	23.8	49.5	35.0	36.8	25.5	18.0	39.0	27.0	18.0	25.5	18.0
	VIP	31.0	42.0	31.0	63.0	45.0	47.25	33.0	23.0	49.5	35.0	23.0	33.0	23.0
	ICE	38.75	52.5	38.75	78.75	56.25	59.625	41.25	28.5	61.25	43.75	28.5	41.25	28.5
Ø 32	Grade 80	28.0	39.2	28.0	58.8	42.0	44.8	31.5	21.0	46.2	32.4	21.0	31.5	21.0
	VIP	35.0	47.6	35.0	73.5	52.5	55.6	39.0	26.25	57.75	40.5	26.25	39.0	26.25
	ICE	43.75	59.5	43.75	91.875	65.625	69.125	47.25	32.25	72.375	50.625	32.25	47.25	32.25

Attention:
 Ac. to BGR 500 section 2.8, the WLL for single fall becomes valid when unsymmetrical load occurs at a multiple strand sling.

Subject to technical modifications! *Only 2 x 2-leg type available.

RUD Ketten
 Rieger & Dietz GmbH u. Co. KG
 Friedensinsel
 73432 Aalen/Germany
 Tel.: +49 7361 504-1316-1370-1224
 Fax: +49 7361 504-1460
 sling@rud.com · www.rud.com

www.rud.com
 Click-lifting means
 click-ICE

