

LIFTING AND LASHING SYSTEMS

— Special Grade 100 —



4 better
lifting



The passion of chain manufacturing!

The round steel chain link production in Unterkochen has been running for almost 140 years. Producing chains for lifting, lashing, conveying, tire protection as well as snow and off-road chains.

Our headquarters and manufacturing plant is one of the most modern chain producing companies world wide.

Developed from a small chain forging company at the river Kocher, the RUD group has stood to the test of time to become a global player with approximately 800 motivated employees, subsidiaries and sales representatives around the world.

Almost 500 national and international protective clauses are the evidence for our progress.

The well established brand name RUD stands for quality, technical innovation and know how. Continuous research and development has enabled us not only to produce products meeting the highest expectations but also with consistent quality standards. Experience, diligence, ambition and passion are the virtues we manifest in order to remain favourite for our customers. With the above virtues in mind, RUD has successfully entered a new century with the trust and satisfaction of our customers as our prime objective for the future.

What are tomorrow's concepts? This is one of the questions which RUD is trying to address while facing the challenge of consistently providing the best solutions to our customers.

2006: First manufacturer who received the "Type Examination Certificate" from the Inspection and Certification authority PZNM of the Technical Committee MO (*Employers Liability Insurance Association = BG), for VIP-round steel chains according to PAS 1061 (Publicity Available Specification according to the Standard DIN EN 818 Grade 100).
As the First H1-10!

2007: RUD receives as the first chain manufacturer the approval for Grade 120 (D1-12) from the BG.



The certified quality management system makes a decisive contribution towards the quality of our products. In combination with the two other certified environmental- and energy management systems the securing of the process quality and the careful and efficient use of resources results from that. Our products are characterized by highest quality and environmental sustainability.

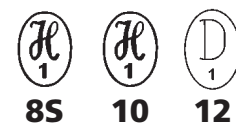

BG and TÜV approved!

*BG = German Employers Liability Assurance Association.

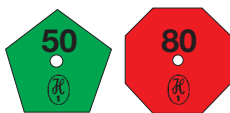

Innovation and quality take first priority at RUD. We are always leading in decisive developments.

Examples in the lifting and lashing chains field:

1967: 1. Approval of quality class 5, H1-5 by the Berufsgenossenschaft (*Employers Liability Insurance Association).

1972: First chain factory to gain approval for the quality class 8, H1-8 by the BG* Technical Committee "Steel and Metal".

The first idea of a **mecano system from RUD** – fool-proof connection of the correct chains and components, as well as suspension links. This idea became the standard at Ruhrkohle RAG.

1981: The first series of lifting points type RBS and RBG with a safety factor 4:1 in any direction.











































1992: First chain factory to obtain certification for their quality assurance system acc. to **DIN/ISO 9001**.

1994: First chain factory to obtain approval of the BG* for their **VIP-special quality** with up to 50 % higher WLL than Grade 80.

2002: The first universal lifting point – called PPS.



CONTENTS

RUD Company Profile/Contents	Page 2/3	
 – Benefits of the RUD-VIP system/applic. examples	4/5	
 – Assembly-fool proof/advantages	6/7	
 – RFID/WLL charts 	8-11	
 – Masterlinks & Special Masterlinks 1 leg	12/13	
 – Masterlinks & Special Masterlinks 2 leg	14/15	
 – Masterlinks & Special Masterlinks 3/4 leg	16/17	
 – Cobra hook – Eye hook – Foundry hook	18/19	
 – Swivel adapter for hoists/Bale hook VIP clevis self locking hook/VIP Grab hook	20/21	
 – Multi shortening claw	22/23	
 – Clevis shackle/Shackle/Isolating plate	24/25	
 – Dumper truck suspension/container hooks Connecting links/Plug-in connector	26/27	
 – Endless chains / length adjustment	28/29	
 – Balancer	30-31	
 – Control link / Swivel / VRG-Connector	32/33	
 – Complete sling chain / Mini-/MAXI mecano system	34/37	
 – Spreader bars (fixed / adjustable)	38/39	
 – Lifting Points (for bolting / for welding)	40-43	
 – Lashing systems / Tensioners	44-47	
 – Inspection/Service/Regular maintenance	48/49	
 – CD ROM/General information	50/51	
Quality in Pink-WLL overview (ICE, VIP, Grade 80)	52/53	

VIP SLING CHAINS IN RUD SPECIAL QUALITY CLASS 10



**VIP-proven since 1994
in the hardest applications!**



- Despite having the same chain diameter, an up to 30 % increase in the WLL in comparison to grade 80.
- Chain dimensions from 4 to 28 mm. WLL from 0.6 t (Mini 1-leg) to 126 t (2x MAXI double leg).
- Distinctive fluorescent pink powder coating and clear „VIP“ stamp on every chain link and component. Distinctive in comparison to other quality classes. Surface quality is comparable to a zinc plated surface.
- Chain diameters 16, 20, 22 and 28 mm in VIP special quality replace the 18, 22, 26 and 32 mm chain diameters of quality grade 8. Smaller chain sizes, hence a considerable reduction of weight which facilitates easy handling.

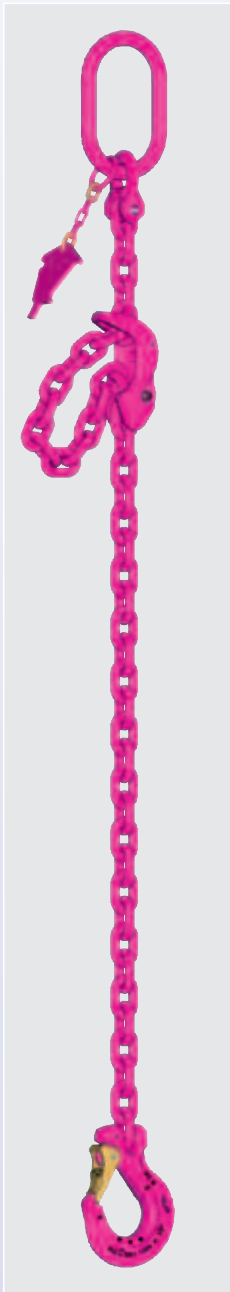

● **Multifunctional WLL identification tag:** Owing to its special patented shape, it facilitates simple inspection of the three wear criteria for sling chains (diameter, elongation of pitch and overload). The inspection data can be documented on the tag.



● **Heat indicator:**
The pink powder coating changes its colour with temperatures exceeding 200°C. Chain must not be used after being subject to temperatures exceeding 380°C. At this temperature the VIP colour changes to a deep black with small bubbles, clearly indicating that it has been overheated.



● **Master link collection for every crane hook:**

The chain connecting link VRG is attached to the corresponding master link in a permanent but flexible way. The fool – proof clevis connection allways ensures that only the correct chain diameter can be fitted. The collection of master links range from the smallest VBK size for the high tensile hoist hooks up to crane hook No. 50 with Bi = 250 mm in 1 to 4 leg assembly versions.

● The patented **multi shortening claw** can be fitted on the chain leg at any required position. No additional chain and coupling parts are required. The robust safety bolt with a spring prevents unintentional hooking out of the chain in both loaded and unloaded conditions. Ideal chain link shaped pocket support, thus no reduction in the WLL (DIN 5692).

● **VIP Cobra hook:**

The compact design of the VIP Cobra hook with no protruding hook tip is far superior and safer than the common clevis sling hook. Supplied complete with a forged and tempered safety latch that locks into the hook tip protects against lateral bending. The safety latch is supported by a triple coiled double leg. The enlarged hook tip prevents misuse. Wear edges on both sides of the hook protect against abrasion of the chain when hauling the chain assemblies. Gauge marks on the hook enable easy inspection for the elongation of the width of the hook opening.

● **VIP automatic clevis hook:**

Extremely robust design. The hook locks automatically when lifting the load and can only be opened by activating the protected unlocking lever at the back of the hook. No protruding hook tip. Large mouth width **size F**.

● **VIP shortening hook:** According to DIN 5692:

With no reduction of WLL and a thickened hook tip to avoid misuse e.g. incorrect fitting of the chain. Ideal chain support facilitated by the calibrated lugs. The U-bend insertion slot protects against accidental chain disengagement.

● **World wide unique:** The VIP Mecano System with the 4 mm and 28 mm chain.



**Mecano System
“in miniature”
4 mm chain and
components!**

VIP-Quality – “Made in Germany!”



VIP[®]



VIP



Application examples – VIP –



Subject to technical modifications!



VIP Stamping – on every chain link

VIP-stamped chains are manufactured with smaller tolerances in the inner width (size W1) and are coated with the fluorescent colour pink. In connection with the VIP stamped, pink coloured components, whose special clevis design has been perfectly harmonised, a distinctive chain connection is realised.

10 or 8 S

The approval of RUD's special quality VIP by the BG* is documented in short chain link intervals with the following: **H1** referring to the manufacturer's number i.e 1 = RUD and **8 S** or **10** meaning Grade 100.

Verification of quality

At regular intervals, the chains are stamped with a serial and batch number. This identification ensures a continuous record tracking of the manufacturing and proof load data even after a period of 10 years. After all we stick to our VIP quality.

Patented heat indicator

In high temperature environments the special fluorescent pink powder coating permanently changes its colour. Above 380°C the colour changes permanently to black. If this happens the chain assembly must be taken out of service (refer to page 7).

The geometric construction and tolerances of the VIP chains are aligned to a higher quality class. On request, **Corrud DS**, a 20 times more red rust resistant component than zinc plating, can be supplied.

VIP Grade 100

A consequential enhancement of the RUD – Mecano system with quality grade 80, which has stood to the test of time for over 30 years. V – distinguished, I – in, P – pink.

Using the patented VIP identification tag, the chain can easily be inspected for wear and pitch elongation. Please refer to pages 10 and 48.

BG* = Employers Liability Insurance Association.

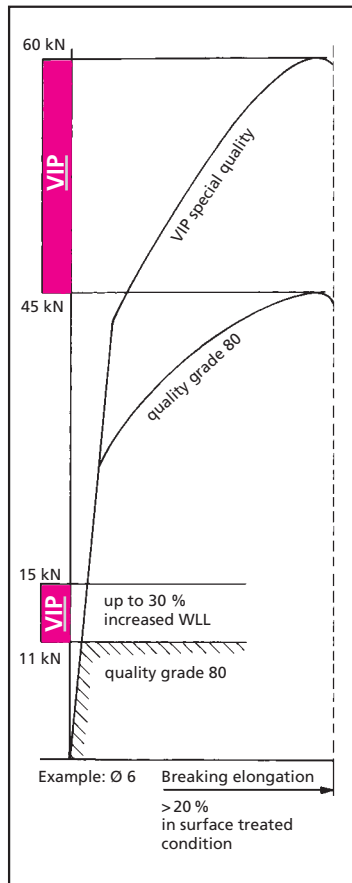

bending $\min f = 0.8 \times d$ is by far exceeded. Ratio of WLL : proof load : breaking load is given by 1 : 2.5 : 4. Owing to a special heat treatment procedure developed by RUD, the highly dynamic RUD – VIP-chains are less sensitive to mechanical abrasion and damages. Hence an increased life expectancy is achieved.

Quality grade 80 chains whose nominal diameter exceeds 18 mm can be substituted by a one size less nominal diameter chains in VIP quality.

Giving the same WLL despite a 50 % weight reduction.

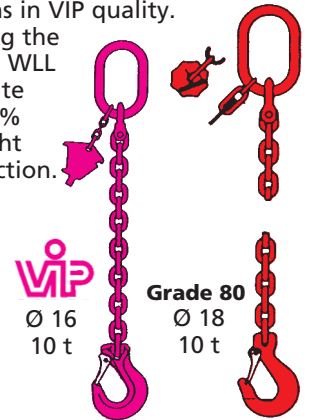

The highly qualitative VIP chains and components are provided with a **duplex surface protection**. This comprises of two processes i.e: Pre-treatment and pink powder coating. Due to this two process procedure, a relatively better surface protection is achieved in comparison to zinc plating.

The highly dynamic **VIP-Mecano system and chains** achieves a dynamic strength higher than the standard values. Tested with over 20,000 load cycles and with a factor ratio of 1.5 of their actual WLL.

An up to 30 % increase in the WLL in comparison to quality class 8

Material CrNiMo alloy steel, specially tempered, high toughness. Minimum breaking elongation $\geq 25\%$ in natural black, $\geq 20\%$ in pink coated.

Less sensitive to notching and hydrogen embrittlement than quality grade 80. Bending tests acc. standard DIN EN 818-2,

RUD VIP- and Grade 80 chains are likewise components according to DIN EN 1677, designed for a dynamic loading of more than 20000 load cycles at a 50 % overload (1.5 x WLL). The BG (German Employers Liability Insurance Association) recommends: At a high number of load cycles (continuous operation), the bearing stress must be reduced according to FEM/ISO classification 1B_m (M3 acc. to EN 818-7); f.e. by using the next bigger chain diameter.

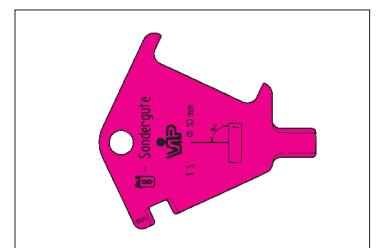

FOOL-PROOF
»IN PINK«

FOOL-PROOF
»IN STAMPING«

FOOL-PROOF
»IN PINK+STAMPING«

The proven clevis connection system has been further enhanced with the new VIP range. With its dimensional adjustments and colour (VIP chains and components in pink) arrangement of the chains and the components, a fool-proof assembly is assured.

Clevis dimension "X" avoids the connection of a larger VIP chain. VIP chains are manufactured with tighter tolerances in the inner width (size W1). The connection bolt diameter "size Y" avoids the connection of the next smaller VIP chain size.

Result:
Only chains and components with the same WLL are distinctively assembled together.

VIP- Fool-proof Mecano assembly

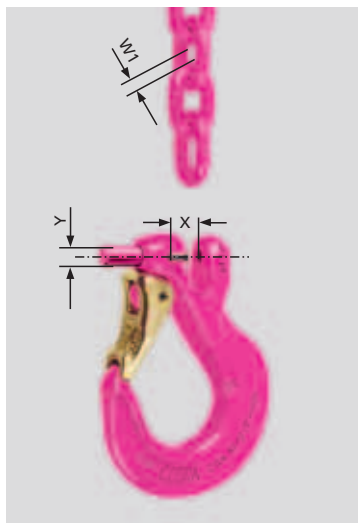

The VG-bolt of the next smaller size drops out.

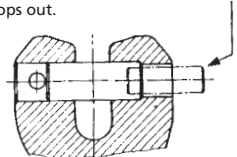

Attention:

VIP chains Ⓜ 85 or 10 must only be connected with RUD components. RUD does not assume liability for VIP chains and VIP components which are combined with competitor products. Observe user instruction resp. owner's manual! Use only original RUD spare parts.

Employer's insurance association requires:

Chain slings of quality grade 100 must not be used in combination with chains and components from other manufactures.



Slot of the tensioning sleeve must be visible facing to the front! The tensioning sleeve must be used only once.



The special fluorescent VIP powder coating permanently shows the temperature to which the VIP chain has been exposed.

Operated in the prohibited temperature ranges i.e. above 380°C, the pink colouration turns black with bubbles on the surface. Replace the VIP chains or return them to the supplier for repair.



Application examples of the versatile VIP system.

Assembly



VIP heat indication
European patent
EP 677681

RUD ID System®

Inspection and documentation made easy!



Regular inspections of lifting applications are an essential requirement to ensure the highest standard of safety is met. Dated methods of inspections involve copious amounts of paper work and time consuming manual processes.

But due to the **RFID-technology** (Radio-Frequency-Identification) these time consuming methods and huge amount of paper work become history.

RFID technology has been specifically designed to track and identify applications quickly and effortlessly making inspections and documentation of products a quick and easy process.

Radio Frequency Identification (RFID) continues to evolve as a major technology – modernizing the way documentation and inventory management is done



RUD ID System®



RUD-ID-POINT®

The **RUD-ID-POINT®** (RFID chip) is embedded into the component. The RFID chip is branded with a unique identification number.

Size comparison:



RUD-ID-READER

The robust RUD reading devices capture the identification number of the **RUD-ID-POINT®** and transfer it to the **RUD-ID-NET®** application (software) or alternatively to your PC applications (e.g. WordPad, MS Word, MS Excel, SAP) etc.



RUD-ID-NET®

The resourceful **RUD-ID-NET®** application (software) will support your product administration and documentation.



RUD ID System®

RUD-ID-Points®



Reference no.:
7902580



Reference no.:
7998881



Reference no.:
7903680



Reference no.:
7901001

The innovative and unrivalled **RUD-ID-POINT®** performs in varied conditions ranging from -80°C temperatures to an astonishing +270°C. They hold a high level of water and pollution resistance and are extremely robust against damage. The RFID-chip does not harm the capability of the components.

RUD-ID-POINT® 8 mm or 4 mm (13.56 MHz HF):

Press-fit transponder (in metal). No glue necessary.

Size: 8 mm x 3.25 mm or 4 mm x 3.50 mm.

The usage of **RFID-Chips** embedded into a component is a patented technological innovation.

RUD-ID-LINK (13.56 MHz HF)

Connecting link with integrated transponder for chains, wire ropes, etc.

Size: dia. 8 mm x 35 mm open

RUD-ID-GLUE® (13.56 MHz HF)

Adhesive metal transponder for many other working means, subject to regular checking (clamps, grippers, cross bars, etc)

Size: dia. 19 mm x 4.5 mm

Additional colors and design on request.

RUD-ID-READER



Reference no.: 7903364



Reference no.: 7901524 (Bluetooth)

The **RUD-ID-EASY-CHECK®** readers are compatible with the **RUD-ID-POINTS®** as well as with common high frequency transponders/chips (ISO 15693). The transfer of the identification number is carried out either by USB or Bluetooth and can be linked up with the **RUD-ID-NET®** application (software), almost all Office applications (WordPad, MS Word, MS Excel, Open Office) and also with SAP or other programs.

RUD-ID-BETTER-CHECK® (13.56 MHz):

USB-reader for identifying the unique number of the **RUD-ID-POINT®**.

RUD-ID-DISPLAY-CHECK® (13.56 MHz):

The unique identification number is shown on the **RUD-ID-POINT®** which is then displayed on the integrated LCD-display. The data can be transferred to any end device capable for Bluetooth 15 metres away.

RUD-ID-NET®

The **RUD-ID-NET®** application (software) has many advantages; it is easy to use, requires no digital maintenance and ensures you manage inspections of products effectively.

- It enriches your data by providing detailed product information, inspection dates, test reports and automatic test reminders to selected employees. The benefits are endless.
- Product information and documentation such as inspection reports and product data can be easily accessed via the RUD web portal.
- Upgradeable software for different work equipment which has to be inspected regularly (f.e. work platforms, roller shutter).





VIP round steel link chain Grade 10

Size d in mm Ø	4	6	8	10	13	16	20	22	28
Pitch P in mm	12	18	24	30	39	48	60	66	84
inside, width W1 bi min. mm	5.2	7.8	10.4	13	17	21	26	28.6	36.4
WLL in t	0.63	1.5	2.5	4.0	6.7	10	16	20	31.5
Proof load MPF min. kN	15.7	37.5	62.5	100	166	250	395	500	772
Breaking load BF min. kN	25	60	100	160	265	400	630	800	1240
Weight kg/m	0.36	0.85	1.5	2.4	4.0	6.0	9.5	12.3	18.6
Surface:	Duplex protection = pre-treatment + pink powder coating								
Order no:	7984399	7100477	7100478	7100479	7100480	7100481	7983689	7100482	7900670
Surface:	Corrud-DS-black								
Order no:	7987349	7988020	7988021	7988754		7903259			

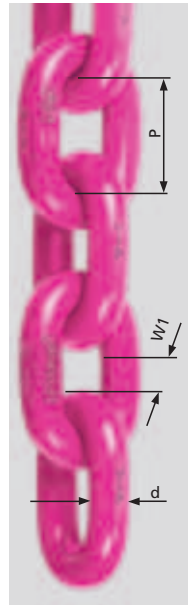

Minimal ultimate elongation: natural black $\geq 25\%$, Pink $\geq 20\%$
 Stamped: VIP identification stamped in every chain link, manufacturing number and the BG approval stamp H1

VIP identification tag with an integrated chain testing gauge EP 610611

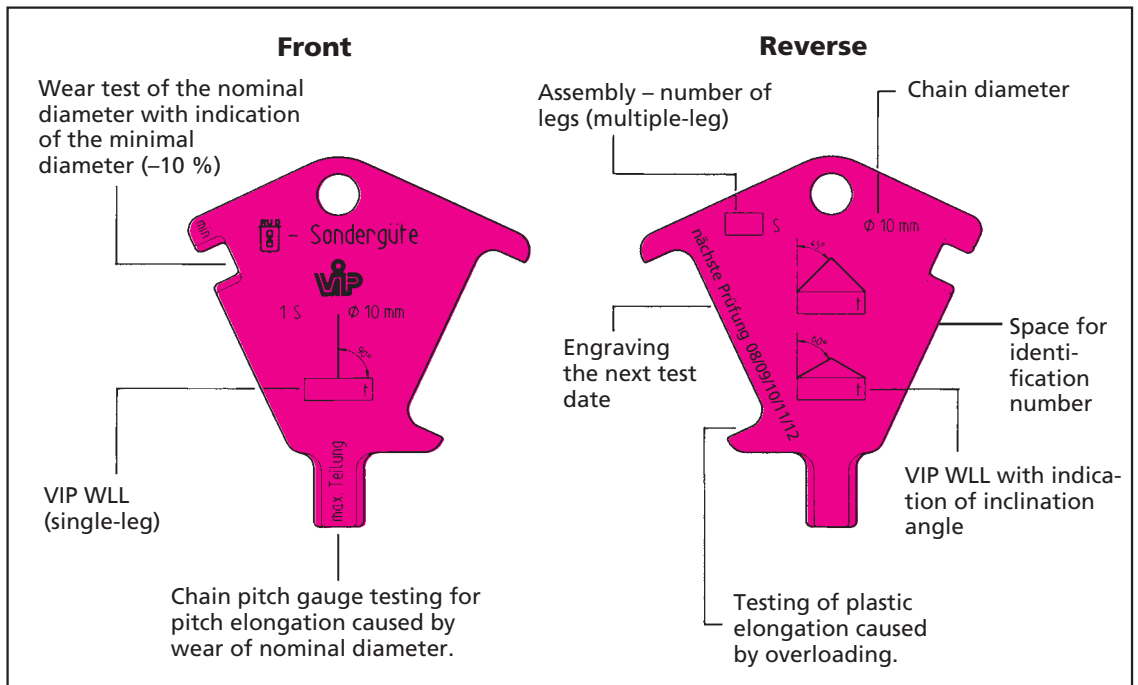

Testing wear of nominal diameter



Testing for plastic elongation caused by overload

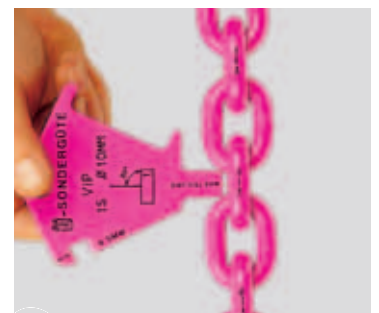

Testing for pitch elongation caused by wear of nominal diameter

	1-leg	2-leg		3- and 4-leg		endless
Nominal size of sling chain in mm						 endless chain sling in choke hitch
Inclination- α β	0°	0-45°	> 45-60°	0-45°	> 45-60°	-
Load factor	1	1.4	1	2.1	1.5	1.6
Ø 4	0.63	0.88	0.63	1.32	0.95	1
6	1.5	2.1	1.5	3.15*	2.25	2.4
8	2.5	3.5	2.5	5.25*	3.75	4
10	4.0	5.6	4.0	8.4*	6.0	6.4
13	6.7	9.5	6.7	14*	10	10.6
16	10	14	10	21*	15	16
20	16	22.4	16	33.6*	24	25.6
22	20	28	20	42*	30	32
28	31.5	45	31.5	67**	47.5**	50
	Acc. to BGR 500 section 2.8, the WLL for single fall becomes valid when unsymmetrical load occurs at a multiple strand sling.					

Please refer to CD-ROM.

* In connection with Balancer 33 % higher WLL possible (see page 30 and 31).

** only 2 x 2 leg type available



VIP Grade 100 WLL in tonnes

of single and multiple leg chain slings with different angles of inclination and **symmetrical loading** of the legs.

Ø 4 mm **>mini** see page 35
 Ø 28 mm **>MAXI** see pages 36/37

In case of choke hitch applications, reduce WLL by 20 %.

A reduction of 20 % for the choke hitch and bundling (sharp edge) is already within the calculation.

**only 2 x 2 leg type available

Nominal size of sling chain in mm	Endless chain				Choke hitch			
	single		double		single		double	
	0-45°	> 45-60°	0-45°	> 45-60°	0°	0-45°	> 45-60°	
Load factor	1.1	0.8	1.7	1.2	0.8	1.1	0.8	
Ø 4	0.69	0.5	1.1	0.75	0.5	0.69	0.5	
6	1.65	1.2	2.55	1.8	1.2	1.65	1.2	
8	2.75	2	4.25	3	2	2.75	2	
10	4.4	3.2	6.8	4.8	3.2	4.4	3.2	
13	7.5	5.3	11.2	8	5.3	7.5	5.3	
16	11	8	17	12	8	11	8	
20	17.6	12.8	27.2	19.2	12.8	17.6	12.8	
22	22	16	34	24	16	22	16	
28	35.5	25	53**	37.5**	25	35.5	25	
	Acc. to BGR 500 section 2.8, the WLL for single fall becomes valid when unsymmetrical load occurs at a multiple strand sling.							
 Temperature °C	When using sling chains at temperatures beyond 200°C (refer to page 7), the permissible WLL has to be reduced. Working load in % at chain temperature of:							
	-40° up to + 200 °C		above 200° - 300 °C		above 300° - 380 °C			
	100 %		90 %		60 %			

Subject to technical modifications!





**VIP Master link
for single leg
VBK1**

**for smaller
load hooks**

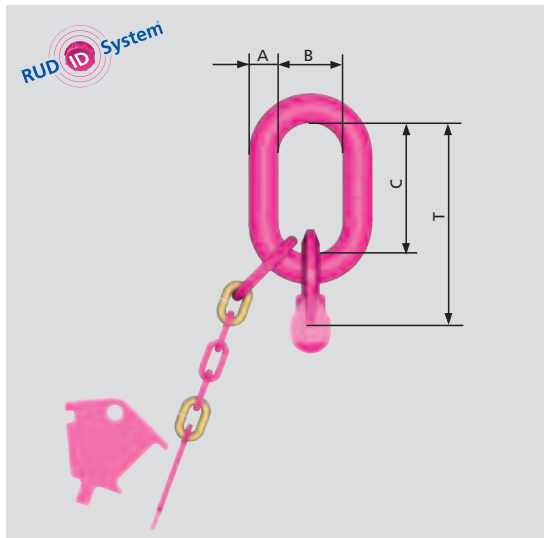

VBK 1 master link with an in all multi-directional movable welded VRG connector. Thus ensuring that the correct chain diameter and number of legs can be connected. Complete identification tag with an integrated testing gauge. Connecting bolt and tensioning sleeve are pre-assembled.

Can also be supplied as **end link (VB-1)** without VIP identification tag.

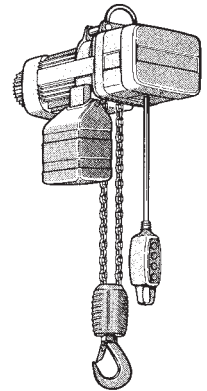

The size corresponds with that of connecting link type B according to DIN 5688. Sufficient for attachment in small load hooks on hoisting devices.

Chain	WLL t	Type	A	B	C	T	kg/pc.	Ref. No.
6	1.5	VBK 1 – 6 (VB 1 – 6)	13	25	54	82	0.5	71 00 675 (71 00 220)
8	2.5	VBK 1 – 8 (VB 1 – 8)	16	34	70	107	0.7	71 00 676 (71 00 220)
10	4	VBK 1 – 10 (VB 1 – 10)	18	40	85	131	1.1	71 00 677 (71 00 222)
13*	6.7	VBK 1 – 13 (VB 1 – 13)	22	50	115	174	2.0	71 00 678 (71 00 223)
16*	10	VBK 1 – 16 (VB 1 – 16)	26	65	140	211	3.3	71 00 679 (71 00 224)
20*	16	VBK 1 – 20 (VB 1 – 20)	32	75	170	264	7.6	71 04 092 (71 04 093)
22*	20	VBK 1 – 22 (VB 1 – 22)	36	110	200	294	9.0	71 00 680 (71 02 060)
28**	31.5	– (VB 1 – 28)	62	130	150	215	13.7	– (79 00 641)**

**VIP Master link
for single leg
VAK 1**

**for
standard
crane hooks
e.g. DIN
15401**

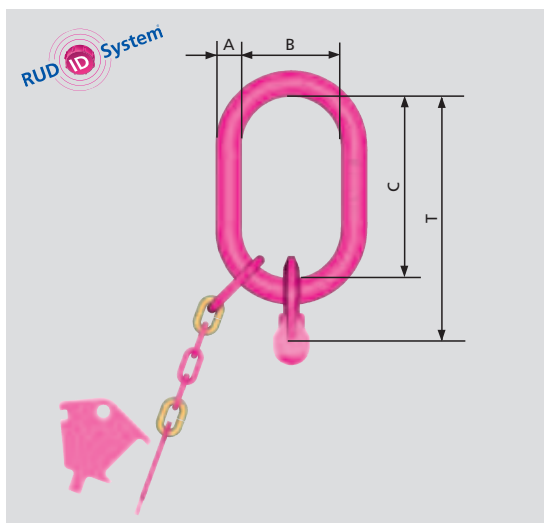

VBK 1 master link with an in all multi-directional movable welded VRG connector. Thus ensuring that the correct chain diameter and number of legs can be connected. Complete identification tag with an integrated testing gauge. Connecting bolt and tensioning sleeve are pre-assembled.

The size corresponds with that of connecting link type A according to DIN 5688.

Master link VAK1 can be used for crane hooks up to No. DIN 15401. – standard size hooks

Size:	6 – No. 2.5	8 – No. 2.5
	10 – No. 5	13 – No. 6
	16 – No. 8	20 – No. 25
	22 – No. 25	

Can also be supplied as **end link (VA-1)** without identification tag.

Chain	WLL t	Type	A	B	C	T	kg/pc.	Ref.No.
6	1.5	VAK 1 – 6 (VA 1 – 6)	13	60	110	138	0.6	71 00 681 (71 00 237)
8	2.5	VAK 1 – 8 (VA 1 – 8)	16	60	110	147	0.9	71 00 682 (71 00 238)
10	4	VAK 1 – 10 (VA 1 – 10)	18	75	135	181	1.4	71 00 683 (71 00 239)
13*	6.7	VAK 1 – 13 (VA 1 – 13)	22	90	160	218	2.4	71 00 684 (71 00 240)
16*	10	VAK 1 – 16 (VA 1 – 16)	26	100	180	250	3.7	71 00 685 (71 00 241)
20*	16	VAK 1 – 20 (VA 1 – 20)	40	180	340	434	14.7	71 04 089 (71 04 090)
22*	20	VAK 1 – 22 (VA 1 – 22)	45	180	340	434	16.5	71 00 686 (71 02 092)
28**	31.5	VAK 1 – 28 –	100	250	280	360	64.3	79 00 642**

*Attention: Master link size 13/16/20/22 with a special identification tag (refer to page 16).
A testing gauge will be additionally supplied with the master link sizes 13/16/20/22
**see MAXI-pages 36/37

VSAK1 master link is supplied complete with a welded VRG connector. Therefore only the correct chain diameter and number of legs can be connected. The identification tag with an integrated testing gauge is already attached.

Connecting bolt and tensioning sleeve are pre-assembled.

Owing to a larger gradation of the inner width „B“ of the VSAK, improper use (BGR 500) is almost eliminated and wear of the crane hook is minimised. Additional connective components for over size hooks are not necessary.

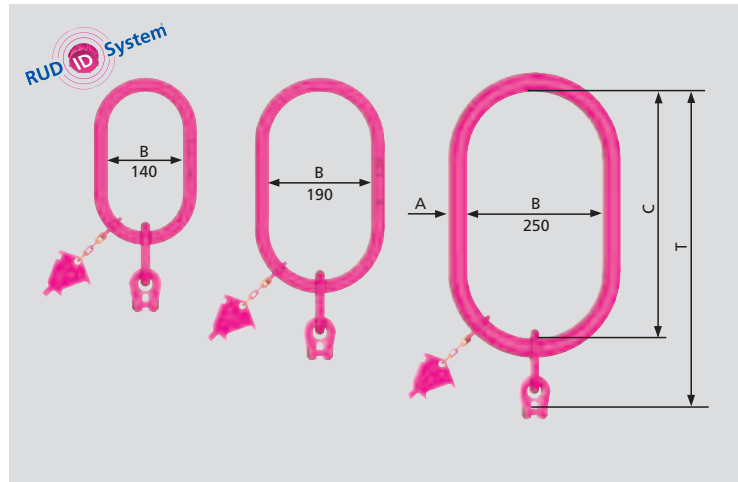

VSAK – size **B** = **140** for standard hooks up to. **No. 16** DIN 15401
 VSAK – size **B** = **190** for standard hooks up to. **No. 32** DIN 15401
 VSAK – size **B** = **250** for standard hooks up to. **No. 50** DIN 15401

Chain	WLL t	Type	A	B	C	T	kg/pc.	Ref. No.
6	1.5	VSAK 1 – 6/140	18	140	260	342	1.7	71 00 687
8	2.5	VSAK 1 – 8/140	22	140	260	367	3.1	71 00 688
10	4	VSAK 1 – 10/140	26	140	260	391	4.4	71 00 689
13*	6.7	VSAK 1 – 13/140	32	140	260	433	7.6	71 00 690
16*	10	VSAK 1 – 16/140	32	140	260	471	8.1	71 00 691

Chain	WLL t	Type	A	B	C	T	kg/pc.	Ref. No.
8	2.5	VSAK 1 – 8/190	22	190	350	457	4.0	71 00 692
10	4	VSAK 1 – 10/190	26	190	350	481	6.0	71 00 693
13*	6.7	VSAK 1 – 13/190	32	190	350	523	9.9	71 00 694
16*	10	VSAK 1 – 16/190	36	190	350	560	13.5	71 00 695

Chain	WLL t	Type	A	B	C	T	kg/pc.	Ref. No.
10	4	VSAK 1 – 10/250	36	250	460	590	12	71 00 696
13*	6.7	VSAK 1 – 13/250	36	250	460	634	13	71 00 697
16*	10	VSAK 1 – 16/250	40	250	460	670	14	71 00 698
20*	16	VSAK 1 – 20/250	45	250	460	724	25	71 04 100
22*	20	VSAK 1 – 22/250	51	250	460	754	33	71 00 699

Forged Special-Link (in pink) for small load hooks, extreme lightweight construction – centre flattening respective to the corresponding chain diameter.

Fits to the Universal-Swivel-PowerPoint from page 33 or to the Lifting Point PowerPoint-B.

Additionally pay attention to the correct WLL assignment while assembling.

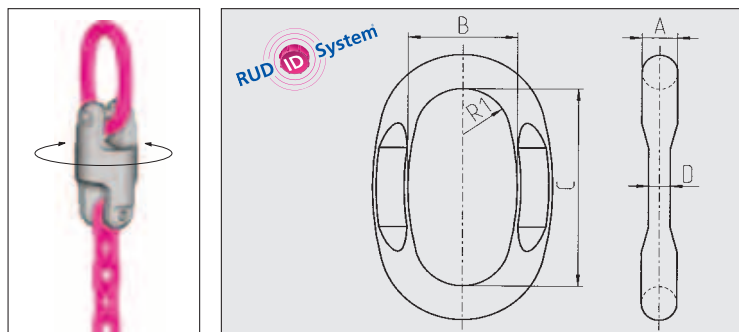

Chain	WLL t	Type	A	B	C	D	R ₁	kg/pc.	Ref. No.
4	0.63	PP 0.63t - B	9	35	65	4	15	0.1	79 89 531
6	1.5	PP 1.5t - B	11	35	65	6	15	0.14	85 02 173
8	2.5	PP 2.5t - B	13	40	75	8	18	0.2	85 02 174
10	4	PP 4t - B	16	45	95	10	20	0.32	85 02 175
13	6.7	PP-VIP Ø 13-B	21	60	130	13	25	1.02	85 02 176
16	10	PP-VIP Ø 16-B	24	65	140	16	28	1.4	85 02 177

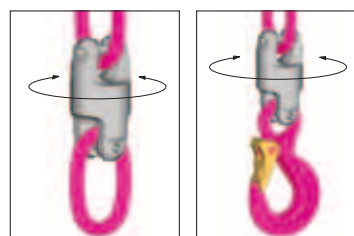

VIP special master link 1-leg VSAK 1

VIP special master link 1-leg PP-X-B – lightweight construction –





**VIP-
Master link
2-leg
VBK 2**

**for smaller
load hooks**

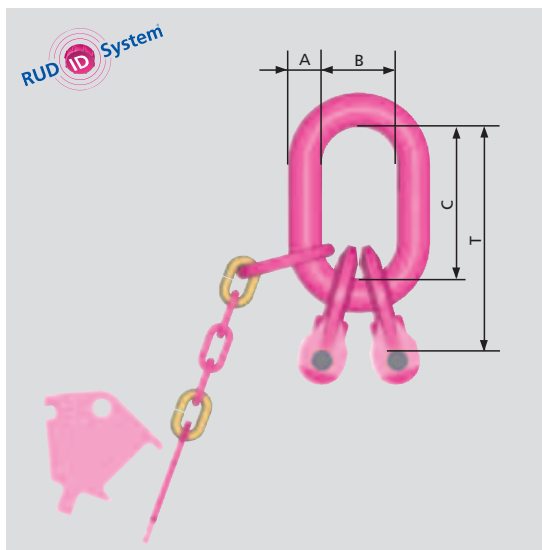

VBK 2 master link is supplied with two welded VRG connectors. Therefore only the correct chain diameter and number of legs can be connected. The identification tag with an integrated testing gauge is already attached. Connecting bolt and tensioning sleeve are pre-assembled.

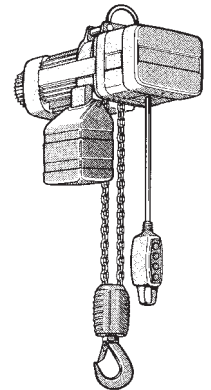

The size corresponds with that of connecting link type B according to DIN 5688. Sufficient for attachment to small load hooks on hoisting devices.

Chain	WLL t	Type	A	B	C	T	kg/pc.	Ref. No.
6	2.1/1.5	VBK 2 – 6	13	25	54	82	0.5	71 00 700
8	3.5/2.5	VBK 2 – 8	16	34	70	107	0.9	71 00 701
10	5.6/4.0	VBK 2 – 10	18	40	85	131	1.4	71 00 702
13*	9.5/6.7	VBK 2 – 13	22	50	115	174	2.7	71 00 703
16*	14/10	VBK 2 – 16	26	65	140	211	4.4	71 00 704
20*	22.4/16	VBK 2 – 20	32	75	170	264	11	71 04 097
22*	28/20	VBK 2 – 22	36	110	200	294	13.7	71 00 705

**VIP-
Master link
2-leg
VAK 2**

**for standard
crane hooks**

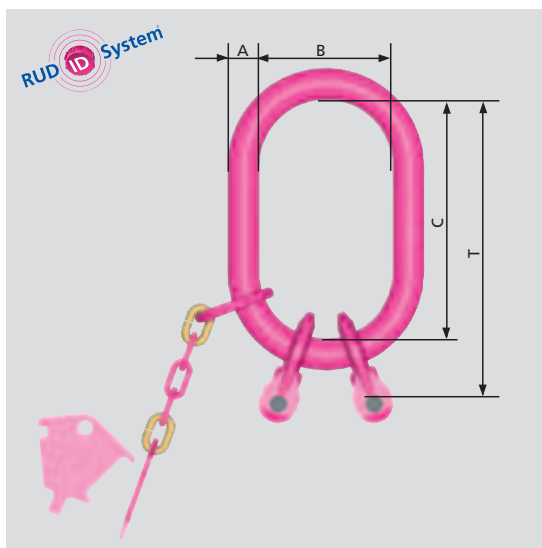

VBK 2 master link is supplied with two welded VRG connectors. Therefore only the correct chain diameter and number of legs can be connected. The identification tag with an integrated testing gauge is already attached. Connecting bolt and tensioning sleeve are pre-assembled.

The size corresponds with that of connecting link type A according to DIN 5688.

Can be used for crane hooks up to No. DIN 15401. - simple hook.

Size:	6 – No. 2.5	8 – No. 5
	10 – No. 6	13 – No. 8
	16 – No. 10	20 – No. 25
	22 – No. 25	

Chain	WLL t	Type	A	B	C	T	kg/pc.	Ref. No.
6	2.1/1.5	VAK 2 – 6	13	60	110	138	0.7	71 00 706
8	3.5/2.5	VAK 2 – 8	18	75	135	172	1.4	71 00 707
10	5.6/4.0	VAK 2 – 10	22	90	160	206	2.3	71 00 708
13*	9.5/6.7	VAK 2 – 13	26	100	180	238	3.9	71 00 709
16*	14/10	VAK 2 – 16	32	110	200	270	6.6	71 00 710
20*	22.4/16	VAK 2 – 20	40	180	340	434	16	71 04 095
22*	28/20	VAK 2 – 22	45	180	340	434	20	71 00 711
28**	45/31.5	VAK 2 – 28	100	250	280	360	64.3	79 00 642

**see MAXI-pages 36/37

VSAK 2 master link is supplied with two welded VRG connectors. Therefore only the correct chain diameter and number of legs can be connected. The identification tag with an integrated testing gauge is already attached.

Connecting bolt and tensioning sleeve are pre-assembled.

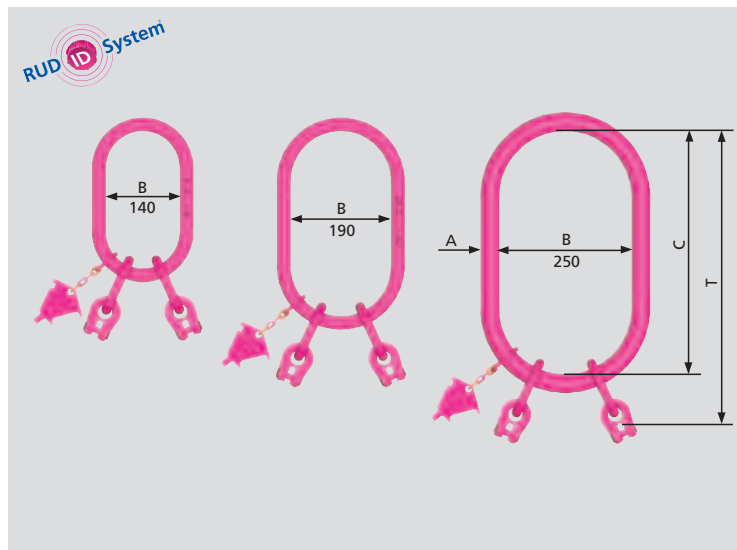

VIP-
special
master link
2-leg
VSAK 2

Owing to a larger gradation of the inner width „B“ of the VSAK, improper use (BGR 500) is almost eliminated and wear of the crane hook is minimised. Additional connective components for over size hooks are not necessary.

VSAK – Size **B = 140** for standard hooks up to **No. 16** DIN 15401
 VSAK – Size **B = 190** for standard hooks up to **No. 32** DIN 15401
 VSAK – Size **B = 250** for standard hooks up to **No. 50** DIN 15401

Chain	WLL t	Type	A	B	C	T	kg/pc.	Ref. No.
6	2.1/1.5	VSAK 2 – 6/140	18	140	260	342	2.3	79 94 070
8	3.5/2.5	VSAK 2 – 8/140	22	140	260	367	3.5	79 94 071
10	5.6/4.0	VSAK 2 – 10/140	26	140	260	391	5.2	79 94 072
13*	9.5/6.7	VSAK 2 – 13/140	32	140	260	433	9.2	79 94 073
16*	14/10	VSAK 2 – 16/140	32	140	260	471	12.5	79 94 074

Chain	WLL t	Type	A	B	C	T	kg/pc.	Ref. No.
8	3.5/2.5	VSAK 2 – 8/190	22	190	350	457	4.3	79 94 075
10	5.6/4.0	VSAK 2 – 10/190	26	190	350	481	6.5	79 94 076
13*	9.5/6.7	VSAK 2 – 13/190	32	190	350	523	10.6	79 94 077
16*	14/10	VSAK 2 – 16/190	36	190	350	560	15.6	79 94 078

Chain	WLL t	Type	A	B	C	T	kg/pc.	Ref. No.
10	5.6/4.0	VSAK 2 – 10/250	36	250	460	591	12.8	79 94 079
13*	9.5/6.7	VSAK 2 – 13/250	36	250	460	634	14.9	79 94 080
16*	14/10	VSAK 2 – 16/250	40	250	460	671	20.5	79 94 081
20*	22.4/16	VSAK 2 – 20/250	45	250	460	724	32.5	79 94 083
22*	28/20	VSAK 2 – 22/250	51	250	460	754	43	79 94 084

subject to technical modifications!

***Attention:** Master link size 13/16/20/22 with a special identification tag (refer to page 16).
 A testing gauge will be additionally supplied with the master link sizes 13/16/20/22





**VIP-
Master link
4-leg
VAK 4**

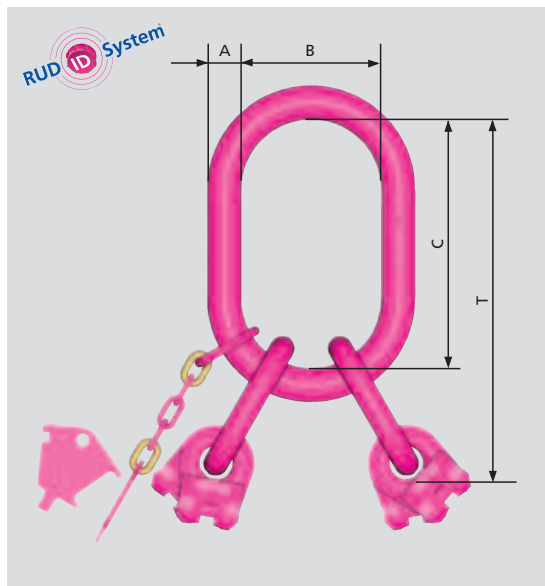

VAK 4 leg master link is supplied with four welded VRG connectors. Therefore only the correct chain diameter and number of legs can be connected. The identification tag with an integrated testing gauge is already attached. Connecting bolt and tensioning sleeve are pre-assembled.

The size corresponds with that of connecting link type A and B according to DIN 5688.

Can be used for crane hooks up to **No.** acc. to DIN 15401.

Size:	6 – No. 5	8 – No. 6
	10 – No. 8	13 – No. 10
	16 – No. 16	20 – No. 32
	22 – No. 32	

Chain	WLL t	Type	A	B	C	T	kg/pc.	Ref. No.
6	3.1/2.2	VAK 4 – 6	18	75	135	217	1.5	71 00 742
8	5.2/3.7	VAK 4 – 8	22	90	160	268	2.8	71 00 743
10	8.4/6.0	VAK 4 – 10	26	100	180	311	4.6	71 00 744
13*	14/10	VAK 4 – 13	32	110	200	373	8.3	71 00 745
16*	21.2/15	VAK 4 – 16	36	140	260	470	13.7	71 00 746
20*	33.6/24	VAK 4 – 20	51	190	350	614	39	71 04 181
22*	42/30	VAK 4 – 22	51	190	350	644	42	71 00 747

***Attention:** Master link size 13/16/20/22 with a special identification tag (refer to page 16). A testing gauge will be additionally supplied with the master link sizes 13/16/20/22

3 leg master links VAK 3 and VSAK 3 do have the same reference numbers as 4 leg master links. No separate stock exists.

**VIP-
Spare parts
VKZA**

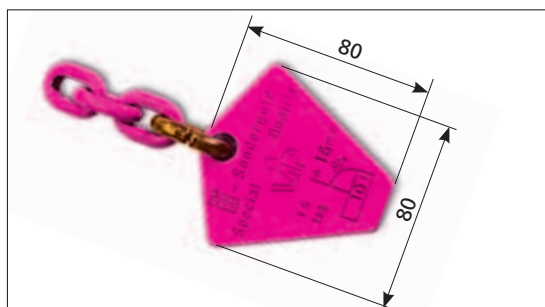

Diameter	Ref. No.
Ø 13 mm/16 mm/20 mm/22 mm/28 mm	79 89 739

VKPL



VIP identification tag as *chain testing gauge, for diameters 13mm/16 mm/20 mm/22 mm

Chain	Type	Ref. No.
13	VKPL-13	71 00 667
16	VKPL-16	71 00 672
20	VKPL-20	71 04 045
22	VKPL-22	71 01 832
28	MAXI-Tester-28	79 00 709

*Comes as separate item with each Masterlink shipment of these sizes.

VSAK 4 master link is supplied with four welded VRG connectors. Therefore only the correct chain diameter and number of legs can be connected. The identification tag with an integrated testing gauge is already attached.

Connecting bolt and tensioning sleeve are pre-assembled.

For the respective crane hooks refer to page 13.

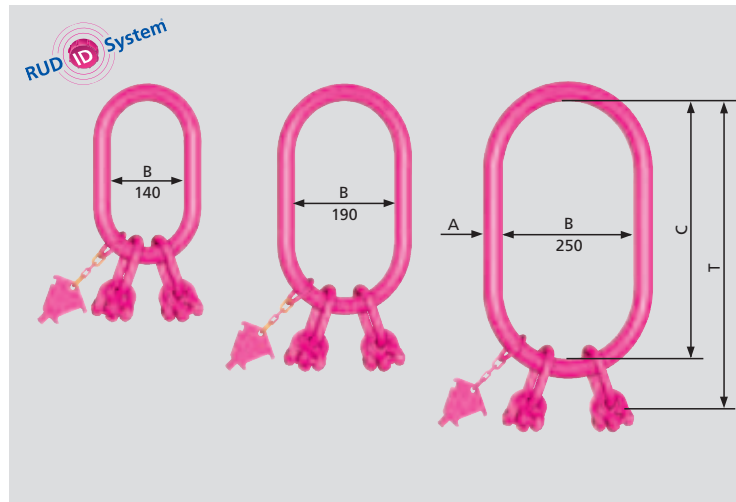

VIP-Special master link 4-leg VSAK 4

Chain	WLL t	Type	A	B	C	T	kg/pc.	Ref. No.
6	3.1/2.2	VSAK 4 – 6/140	22	140	260	342	3.3	71 00 748
8	5.2/3.7	VSAK 4 – 8/140	26	140	260	367	5.0	71 00 749
10	8.4/6.0	VSAK 4 – 10/140	32	140	260	391	7.9	71 00 750

Chain	WLL t	Type	A	B	C	T	kg/pc.	Ref. No.
6	3.1/2.2	VSAK 4 – 6/190	22	190	350	432	3.6	71 00 751
8	5.2/3.7	VSAK 4 – 8/190	26	190	350	457	5.5	71 00 752
10	8.4/6.0	VSAK 4 – 10/190	32	190	350	481	9.2	71 00 753
13*	14/10	VSAK 4 – 13/190	36	190	350	523	13.5	71 00 754

Chain	WLL t	Type	A	B	C	T	kg/pc.	Ref. No.
10	8.4/6.0	VSAK 4 – 10/250	36	250	460	591	14.8	71 00 755
13*	14/10	VSAK 4 – 13/250	40	250	460	634	20.4	71 00 756
16*	21.2/15	VSAK 4 – 16/250	51	250	460	671	34.5	71 00 757
20*	33.6/24	VSAK 4 – 20/250	54	250	460	754	45.5	**79 93 210
22*	42/30	VSAK 4 – 22/250	56	250	460	763	53.6	**79 93 211

***Attention:** Master link size 13/16/20/22 with a special identification tag (refer to page 16). A testing gauge will be additionally supplied with the master link sizes 13/16/20/22

**with VVS-connection



VIP identification tag with integrated testing gauge.

Chain	Type	Ref. No.
4	VKZA-4	79 87 054
6	VKZA-6	71 00 804
8	VKZA-8	71 00 805
10	VKZA-10	71 00 806
13	VKZA-13	71 00 807

VIP-spare parts VKZA

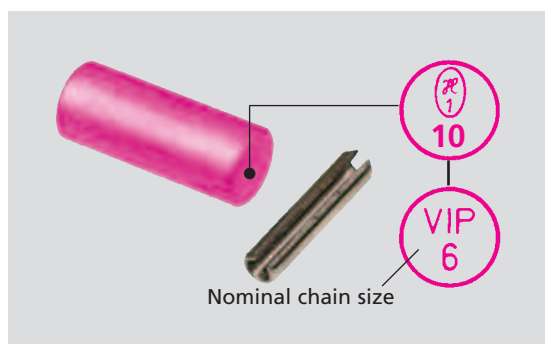

VG bolts with tensioning sleeves

Chain	Type	Ref. No.
4	VG-4/retaining pin 4	79 84 300/51 299
6	VG-6/retaining pin 6	71 01 594/59 289
8	VG-8/retaining pin 8	71 01 595/57 490
10	VG-10/retaining pin 10	71 01 596/59 021
13	VG-13/retaining pin 13	71 01 597/59 022
16	VG-16/retaining pin 16	71 01 598/59 023
20	VG-20/retaining pin 20	71 02 717/59 386
22	VG-22/retaining pin 22	71 01 599/59 387
28	VG-28/retaining pin 28	79 00 708/63 416

VG/SP





VIP-Cobra hook with safety latch VCGH

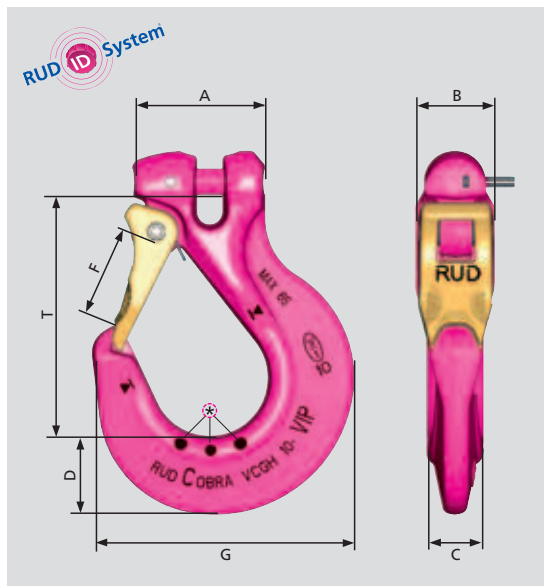

Extremely robust improved version.

No protruding hook tip.

Forged safety latch engages into the tip of the hook and is thus protected against lateral bending.

A triple-coiled, double-leg spring in stainless steel. Thickened tip of the hook prevents misuse.

Wearing edges on both sides.

Gauge marks for measuring the width of the hook opening.

* Patented wear markings are showing the moment of replacement acc. To BGR 500, Chapter 2.8 without the necessity of measuring.

Fmax. = Maximum distance between the gauge marks.



Chain	WLL t	Type	A	B	C	D	F	F max.	G	T	kg/pc.	Ref. No.
6	1.5	VCGH 6	38	22	16	20	25	45	72	76	0.4	71 00 498
8	2.5	VCGH 8	50	28	20	28	30	52	95	97	0.9	71 00 499
10	4.0	VCGH 10	60	36	26	36	35	65	118	108	1.5	71 00 500
13	6.7	VCGH 13	76	46	30	37	40	73	135	126	2.7	71 00 501
16	10.0	VCGH 16	83	56	36	49	48	87	161	152	4.3	71 00 502
20	16.0	VCGH 20	112	68	50	69	63	114	218	195	10.0	71 03 385
22	20.0	VCGH 22	117	78	50	74	63	114	223	198	11.5	71 01 603
28	31.5	VCGH 28	150	101	69	88	90	155	295	275	26.4	79 00 638

VIP-Cobra-eye hook with safety latch VCÖH

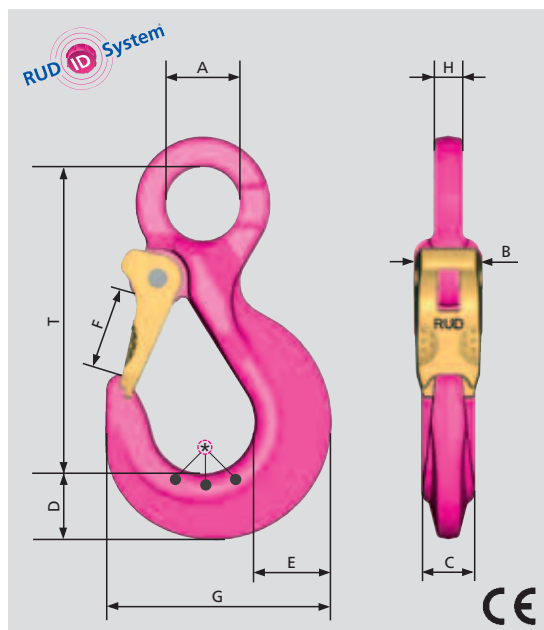

For special wire rope slings, VIP chain slings, PowerPoint combinations or the universal swivel (refer to page 29).

Extreme durable, compact design, with pink powder coating.

No protruding hook tip.

The forged, quenched and tempered safety latch, engages into the hook tip.

Therefore protected against lateral bending.

Triple coiled, stainless steel double leg spring.

Thickened hook tip to avoid improper use.

Wear edges on both sides.

Gauge marks for measuring the width of the hook opening.

* Patented wear markings are showing the moment of replacement acc. To BGR 500, Chapter 2.8 without the necessity of measuring.

Fmax. = Distance between the gauge marks, see VCGH data above.

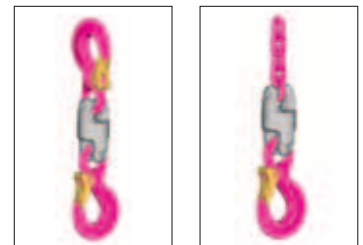

Chain	WLL t	Type	A	B	C	D	E	F	G	H	T	kg/pc.	Ref. No.
4	0.63	VCÖH 4	18	18	12	13	14	18	52	8	75	0.14	85 02 323
6	1.5	VCÖH 6	24	22	16	22	24	25	73	11	98	0.5	85 02 203
8	2.5	VCÖH 8	32	28	20	28	31	30	95	13	126	0.8	85 02 142
10	4.0	VCÖH 10	38	36	26	36	39	35	118	17	150	1.6	85 02 145
13	6.7	VCÖH 13	48	45	30	37	48	40	135	21	170	2.9	85 02 204
16	10	VCÖH 16	63	56	36	49	58	48	161	27	208	4.2	85 02 146

Considerably larger mouth width than VCGH, but without a safety latch.
Use only where unintentional unhooking is impossible.

Inappropriate for overhead lifting!

When using foundry hooks, special attention must be paid and a risk assessment must be carried out before using.

Robust cross section (size C/G) is resistant against increased lateral forces.
Specially designed wearing edges to protect the chain link, compare the dimension „E“.
Connecting bolt and tensioning sleeve are pre-assembled.

Gauge marks for measuring the width of the hook opening.

Fmax. = Maximum distance between marked points.

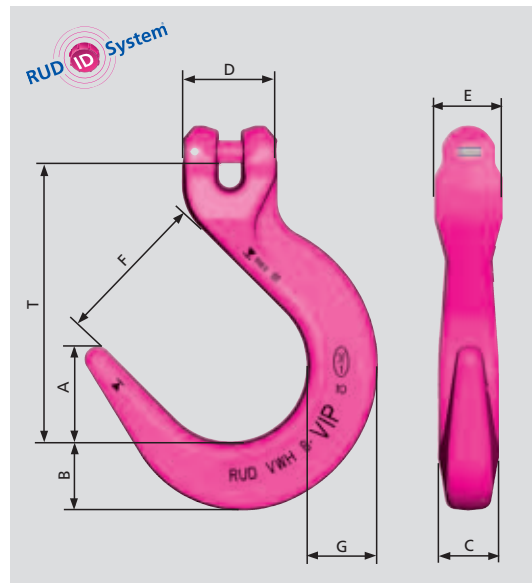

VIP-Foundry hook VWH

Chain	WLL t	Type	A	B	C	D	E	F	F max.	G	T	kg/pc.	Ref. No.
6	1.5	VWH 6	30	22	18	30	22	50	63	22	87	0.5	71 00 210
8	2.5	VWH 8	40	29	26	40	29	64	81	30	115	0.9	71 00 211
10	4.0	VWH 10	46	37	30	50	36	76	96	37	130	1.7	71 00 212
13*	6.7	VWH 13	58	44	31	64	46	90	127	47	168	3.0	71 00 213
16	10.0	VWH 16	64	56	40	75	56	100	129	58	190	5.7	71 00 214
20*	16	VWH 20	96	80	73	102	80	136	183	80	277	15.1	79 98 157
22*	20	VWH 22	96	80	73	102	80	136	183	80	277	15.1	79 98 158

*weight optimized in Skeletto-Technology and patented wear marks.

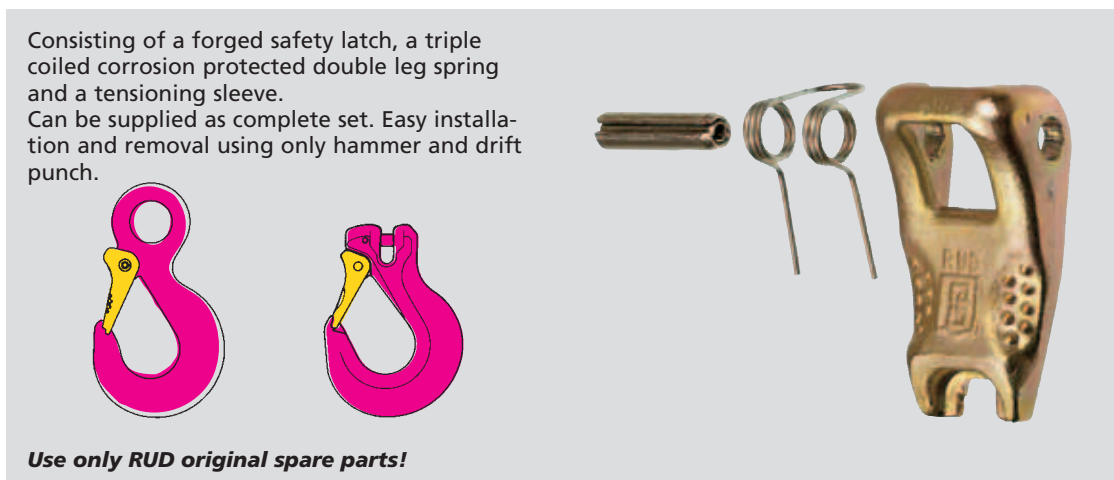

Safety latch set for VCGH

Use only RUD original spare parts!

Chain	Type	kg/pc.	Ref. No.
4	Si-Set VMH-4	0.04	79 87 901
6	Si-Set VCGH-6	0.04	71 00 299
8	Si-Set VCGH-8	0.07	71 00 300
10	Si-Set VCGH-10	0.09	71 00 301
13	Si-Set VCGH-13	0.15	71 00 302
16	Si-Set VCGH-16	0.24	71 00 303
20	Si-Set VCGH-20	0.40	71 01 604
22	Si-Set VCGH-22	0.40	71 01 604
28	Si-Set VCGH-28	1.6	79 00 640

Can also be used as spare part for the RUD-GSH 80 hook.

subject to technical modifications!





Hoist Swivel adapter HWA

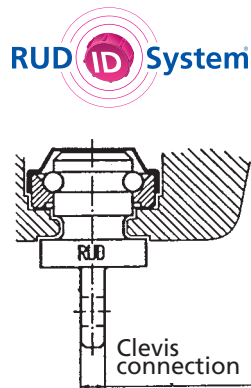
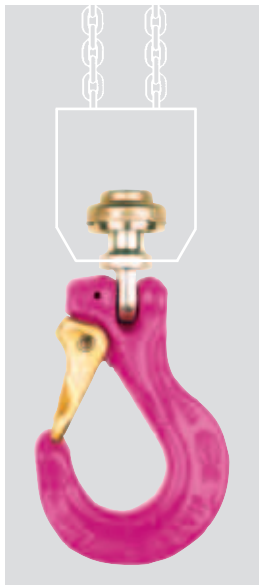

- Supplied complete with original Demag ball bearing
- Manufactured from high-tempered special steel
- tested acc. to EN 1677
- suitable for single leg snatch blocks and for double leg lower blocks
- suitable for all RUD clevis Mecano components

for Demag hoists

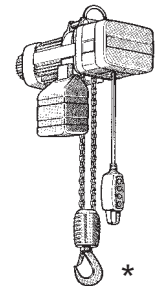

Application examples:

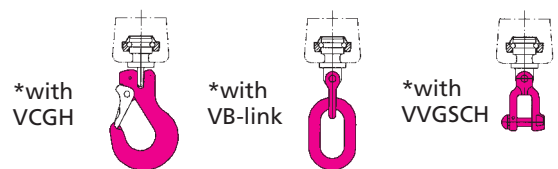

for Demag-DK-hoists

Type	WLL t	Clevis connection	kg/pc.	Ref. No.
HWA 6 DK 400*	DC 1+2 up to 250 kg	0.4	6	0.15 7985570
HWA 6 DK 800*	DC 5 up to 500 kg	0.8	6	0.30 7985571
HWA 8 DK 800*	DC 5 up to 500 kg	0.8	8	0.40 7985572
HWA 8 DK 1250*	DC 10+20 up to 1000 kg	1.25	8	0.55 7985573
HWA 10 DK 2500*	DC 20** 1000-2000 kg	2.5	10	0.90 7985574
HWA 13 DK 5000		5.0	13	1.3 7985575

for Demag-PK-hoists

Type	WLL kg	Ref. No.
HWA 6 PK (1)	250	51 287
HWA 6 PK (2)	500	51 288
HWA 8 PK (2)	500	51 293
HWA 8 PK (5)	1000	51 294
HWA 10 PK (10)	2000	51 295

- ** only in combination with Demag DK bottom block
- also suitable for type series DC-Pro, DCS-Pro and DC-COM

VIP-Bale hook VBMH with ball-bearing swivel

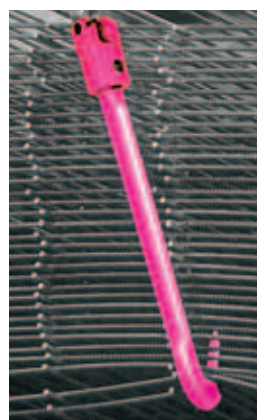
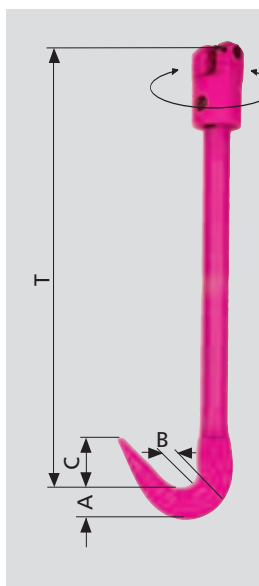

The bevelling on the back of the hook simplifies the horizontal hook insertion between the bales. The clevis connection enables a direct chain connection and the integrated ball bearing swivel prevents the chain from automatically spinning.

Suitable only for the transport of bundled bale packages.

Not suitable for choke lifts!

Inappropriate for overhead lifting!

When using bale hooks, special attention must be paid and a risk assessment must be carried out before using.



Chain	WLL t	Type	A	B	C	T	kg/pc.	Ref. No.
8	2.5	VBMHWA - 8	35	18	61	381	2.5	79 91 478
10	4.0	VBMHWA -10	35	18	61	381	2.5	79 89 017

- Optimized weight by innovative structure design (Skeletto).
- Locking device designed ergonomically, easy to handle with anti-slip-surface – no danger of bruise.
- Wear distance ridges which protect the first chain link.
- Thickened tip of the hook – prevents incorrect an dangerous use of the hook tip.
- Marker points to check the width of the hook on inspection (often copied).

* Patented wear markings are showing the moment of replacement acc. To BGR 500, Chapter 2.8 without the necessity of measuring.

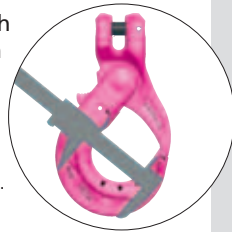

Chain	WLL t	Type	A	B	C	D	E	F	F _{max}	T	kg/pc.	Ref. No.
8	2.5	VAGH (S)-8	40	30	27	28	97	44	60	121	1.0	79 00 046
10	4.0	VAGH (S)-10	49	37	30	31	107	48	66	135	1.5	79 00 047
13	6.7	VAGH (S)-13	61	48	36	40	133	61	81	169	2.9	79 00 048

- No reduction of the VIP-WLL.
- Thickened hook tip to avoid misuse e.g; incorrect insertion of the chain.
- The calibrated tooth lugs facilitate an optimal chain positioning in the hook.
- The curved insertion opening prevents the chain from easily falling out in compliance with DIN 5692.
- Connecting bolt and tensioning sleeve are pre-assembled.

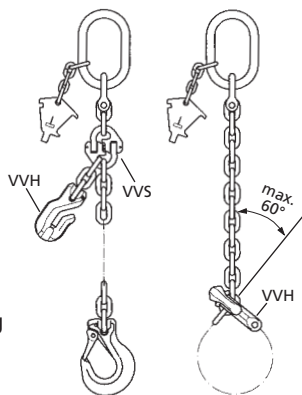

Shortening by means of VVS and VVH

Endless chain by means of VVH

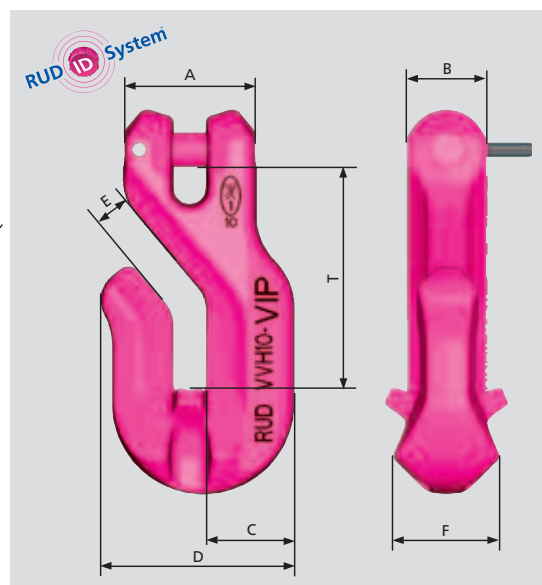

VIP-shortening hook VVH



Special designed hook tip to avoid misuse.



Probable misuse!

Chain	WLL t	Type	A	B	C	D	E	F	T	kg/pc.	Ref. No.
6	1.5	VVH 6	34	18	20	44	7.5	23	53	0.27	79 88 658
8	2.5	VVH 8	38	22	25	54	9.5	33	64	0.35	79 87 319
10	4.0	VVH 10	47	28	31	68	12	42	80	0.8	79 87 320
13	6.7	VVH 13	60	36	40	87	15	47	103	2.2	79 87 321
16	10.0	VVH 16	75	45	50	108	18.5	57	125	3.5	79 88 669
20	16.0	VVH 20	92	58	63	138	24	76	162	8.4	85 03 630
22	20.0	VVH 22	102	62	69	151	26	83	179	11.0	85 03 631

Attention:
Standard for shortening elements DIN 5692!
All RUD shortening components do already fulfil these requirements.

Subject to technical modifications!





**VIP-
Multi-
shortening
claw
VMVK
EP 0736150**

Attention:

Standard for shortening elements DIN 5692! All RUD shortening components do already fulfil these requirements.

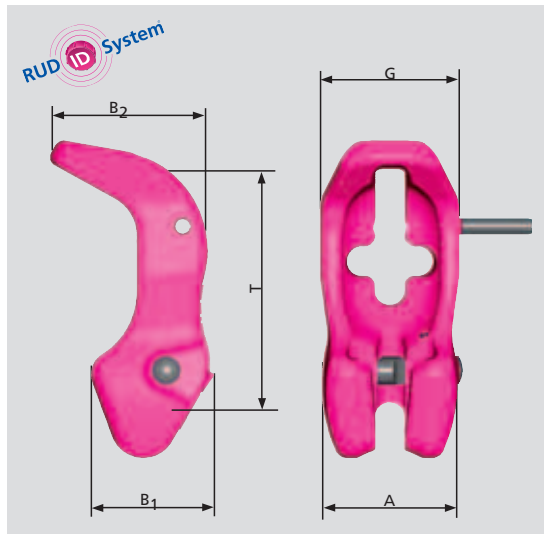

After decades of success the RUD shortening claw has been further enhanced. Fitted on a continuous chain strand at any required position. Fitted permanently on the chain leg at any required position, no additional chain coupling devices are required. It can either be mounted or easily moved to any position along the chain leg. The ideal link shaped chain pocket facilitates even wearing of the chain **thus no reduction of the WLL**. A robust safety bolt with spring prevents accidental loosening of the chain in both loaded and unloaded condition. In case of a mounted but not firmly fixed VMVK, please adhere to the instructions marked "Attention" below.

Complies with DIN 5692.

Chain	WLL t	Type	A	B ₁	B ₂	T	G	kg/pc.	Ref. No.
6	1.5	VMVK 6	38	34	40	66	38	0.3	79 84 072
8	2.5	VMVK 8	46	41	52	88	48	0.55	71 00 760
10	4.0	VMVK 10	58	50	64	110	60	1.1	71 00 761
13	6.7	VMVK 13	74	64	86	143	76	2.4	71 00 762
16	10.0	VMVK 16	91	79	105	176	98	4.4	71 00 763

**VMVK
Fitting and
Handling**

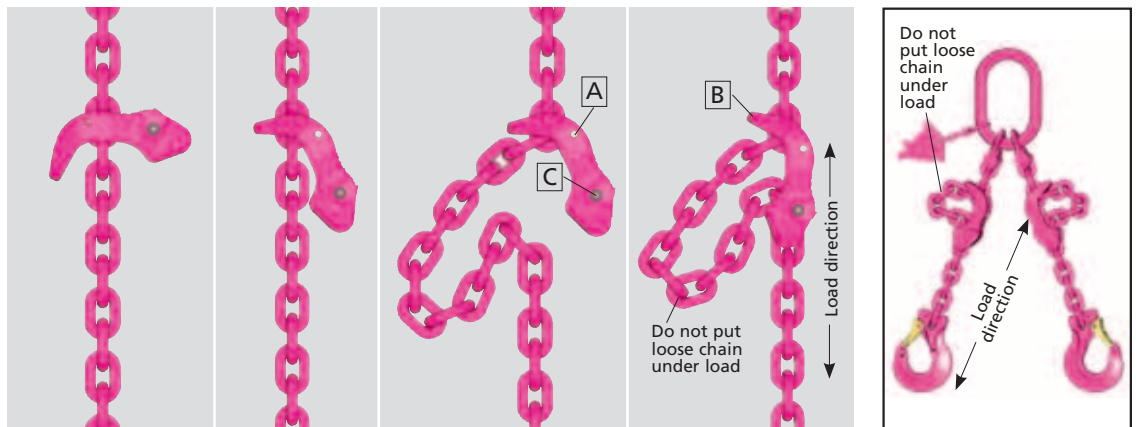

A Securing pin

B Locking groove

C Securing bolt





**VIP-
shortening
claw
VV-20/22/28**

Attention:
Standard for shortening elements DIN 5692!
All RUD shortening components do already fulfil these requirements.

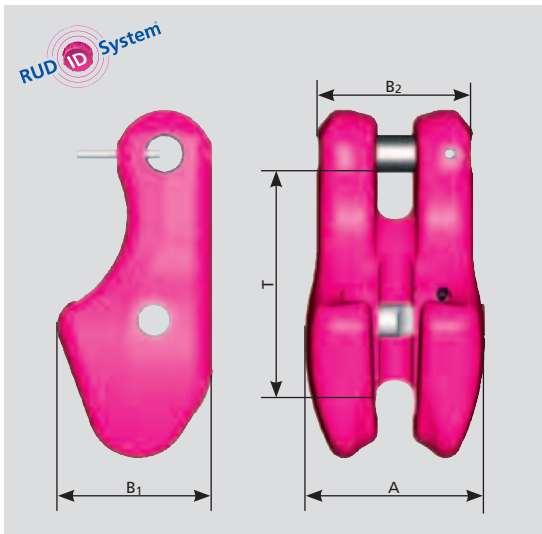

For the 20, 22 and 28 mm VIP-chain, only the standard shortening claw is available in VIP quality.

- Pocket support is gentle to chain
- no reduction of WLL
- light construction

The robust safety bolt supported by a spring avoids an unintentional dismounting of the chain in unloaded as well as loaded conditions. Complies with DIN 5692.

Chain	WLL t	Type	A	B ₁	B ₂	T	G	kg/pc.	Ref. No.
20	16	VV 20	117	101	102	140	–	8.8	79 94 856
22	20	VV 22	117	101	102	140	–	8.5	79 94 855
28	31.5	VV 28	150	130	130	170	–	16.9	79 00 643

Assembly for Ø 20 and 22:	Assembly for Ø 20 and 22:	Assembly for Ø 20 and 22:
1-leg – adjustable – fully captive	2-leg – adjustable – fully captive	4-leg – adjustable – fully captive
<p>Example:</p> <p>VAK 2-22</p>	<p>VAK 4-22</p>	<p>VAK 4-22</p>

Attention:
Fit with a 1-leg VKZA-tag

Attention:
Fit with a 2-leg VKZA-tag





VIP- fool-proof shackle VV-GSCH

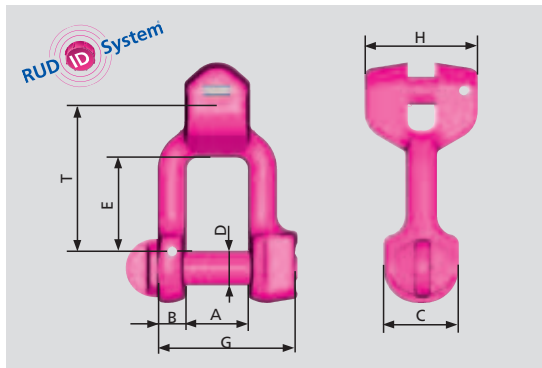

For technical description of the shackle refer to VV-SCH.

- Optimal dimensions – max. mouth width with smallest shackle bolt.
- Due to a turned clevis connection, the shackle is extremely resistant against bending.

Chain	WLL t	Type	A	B	C	D	E	G	H	T	kg/pc.	Ref. No.
6	1.5	VV-GSCH 6	17	8	22	10	21	40	28	36	0.15	71 02 022
8	2.5	VV-GSCH 8	21	10	26	12	32	48	39	48	0.26	71 02 023
10	4.0	VV-GSCH 10	27	13	34	16	35	62	45	61	0.65	71 02 024
13	6.7	VV-GSCH 13	33	17	42	20	41	81	59	78	1.35	71 02 025
16	10.0	VV-GSCH 16	38	22	49	24	49	95	69	96	2.5	71 02 026
20	16.0	VV-GSCH 20	47	27	60	30	57	119	88	108	3.9	71 04 284
22	20.0	VV-GSCH 22	53	30	76	36	72	130	95	132	6.7	71 02 027

VIP- fool-proof shackle VV-SCH

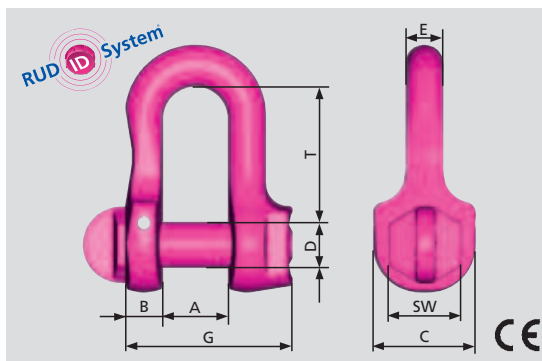

High-tensile patented version with an integrated safety thread in the shackle bracket. On both sides, smooth bolt support in the shackle. Bolt is turnable. No bending strength in the thread, it has only a securing function.

Pre-assembled with tensioning sleeve. Long term securing by driving in a tensioning sleeve. Special thread, thus fool-proof compared to other shackle bolts! Surface is pink powder coated.



Chain	WLL t	Type	A	B	C	D	E	G	SW	T	kg/pc.	Ref. No.
6	1.5	VV-SCH 6	14	8	22	10	8	36	17	30	0.1	71 00 607
8	2.5	VV-SCH 8	17	10	26	12	10	44	19	36	0.2	71 00 608
10	4.0	VV-SCH 10	21	13	34	16	13	56	24	49	0.4	71 00 609
13	6.7	VV-SCH 13	27	17	42	20	17	75	29	63	0.8	71 00 610
16	10.0	VV-SCH 16	33	21	49	24	21	90	36	73	1.5	71 00 611

VIP- Shackle high-tensile VC-SCH

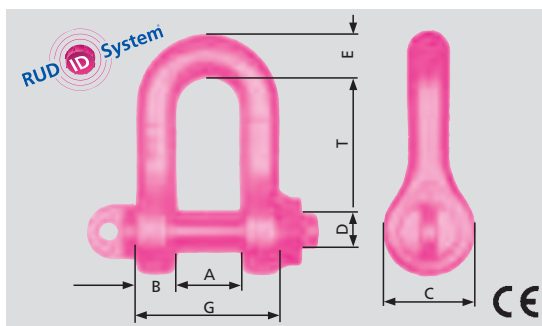

Shape acc. to DIN 82 101-C with an attached fixed nut. Securing by split-pin. Surface is pink powder coated.

WLL t	Type	A	B	C	D	E	F	G	T	kg/pc.	Ref. No.
14.0	VC-SCH 4.0	42	27	60	30	29	27	96	91	2.7	79 84 331
22.4	VC-SCH 5.0	47	30	72	36	33	30	107	111	4.4	79 84 332
31.5	VC-SCH 6.0	53	34	78	39	37	34	121	120	5.9	79 84 333

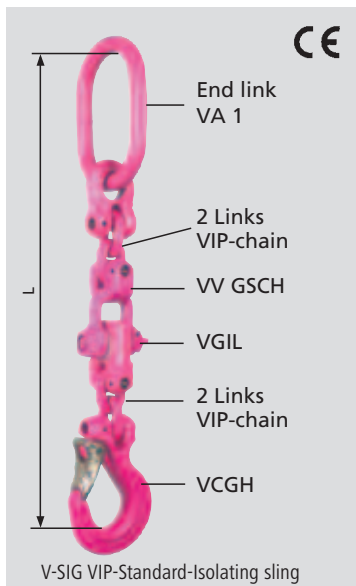
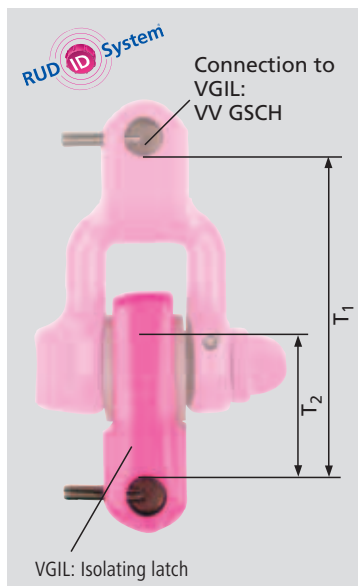

VIP-Isolating Assembly

VIP-Isolating latch VGIL + VV GSCH

Up to 1000 V



Chain	WLL t	Type	T ₁	T ₂	L	Weight/ kg	Ref. No. V-SIG	Ref. No. VGIL
6	1.5	VGIL-6	71	35	357	1.4	79 84 258	79 84 161
8	2.5	VGIL-8	91	43	431	2.4	79 84 259	79 84 162
10	4.0	VGIL-10	108	47	517	4.3	79 84 260	79 84 163
13	6.7	VGIL-13	132	54	632	8.2	79 84 261	79 84 164
16	10.0	VGIL-16	166	70	760	13.1	79 84 262	79 84 165

There is a danger of current flow when welding is carried out on suspended loads. The isolating latch isolates up to max. 1,000 V by means of a special non conductive plastic bearing of the clevis shackle bolt. Max operational temperature is +80°C.



Finally!
Ensures even load distribution by means of a compensating pulley with a VVGSC8. There is neither overload nor deformation of the concrete element.
8 mm $\angle \beta_1$: max. 45°
6 mm $\angle \beta_2$: max. 30°

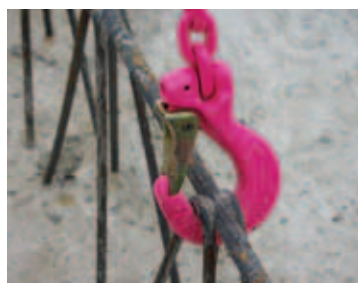

RUD VIP Cobra hook:
with a robust hook securing, small, handy and easy to hook-in in both diagonal and upper chords.

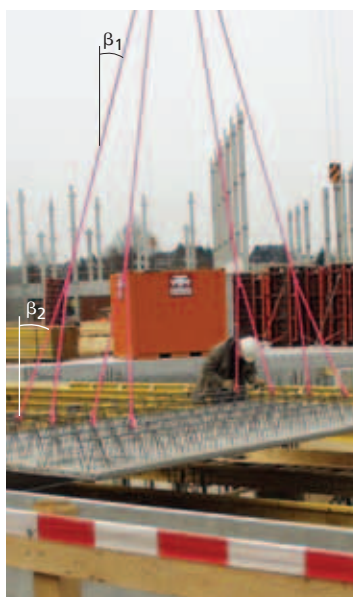

VIP-Balancing assembly „VIP-octopus“ for concrete elements

Chain	WLL t	Type	Ref. No. complete	Ref. No. clevis shackle with a deflection pulley
8/6	5.25	VIP-octopus 8 x 5000	79 87 582	79 87 366



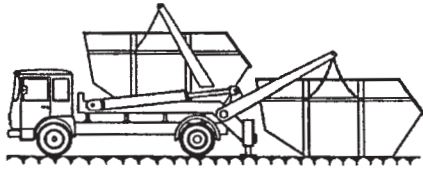

VIP-Dumper truck suspension-ring VMEG

VIP-Dump truck-Automatic-Clevis hook VMAGH (S)

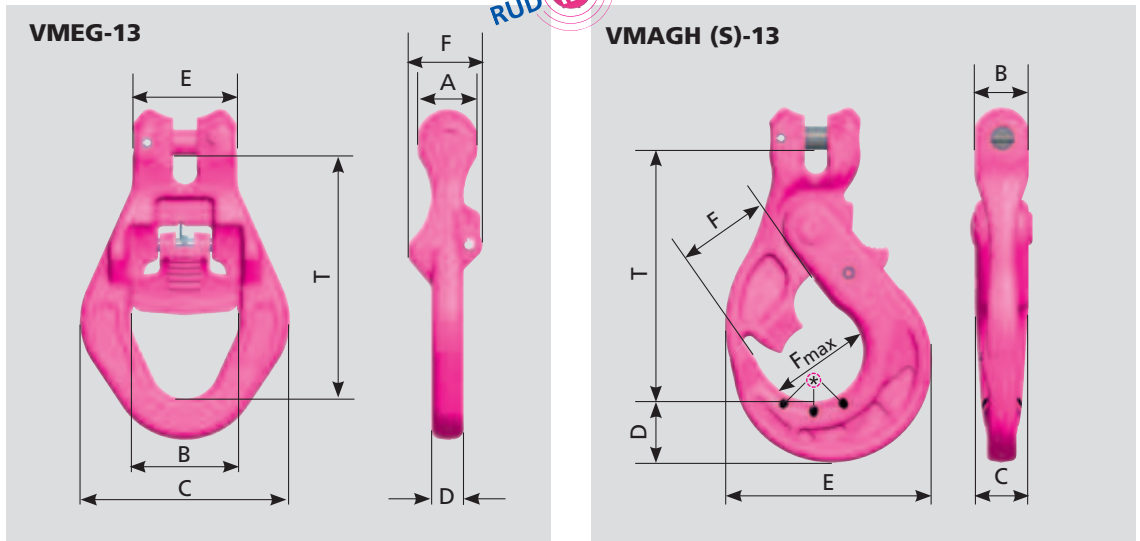

VMEG and VMAGH(S):

Suitable for standardized dump truck studs, quick attachment and anyway safe hold.

Chain	Type	WLL t	A	B	C	D	E	F	F _{max}	T	kg/pc.	Ref. No.
13	VMEG-13	6.7	37	66	128	20	64	46	-	149	2.6	79 02 657
13	VMAGH (S)-13	6.7	61	37	36	40	137	50	81	167	3	79 02 114

* Patented wear markings are showing the moment of replacement acc. To BGR 500, Chapter 2.8 without the necessity of measuring.

VIP-Container hook VCH

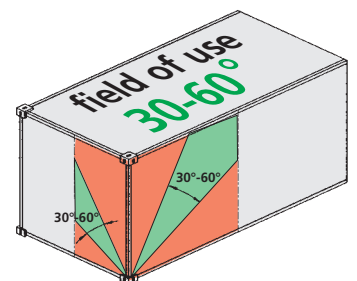
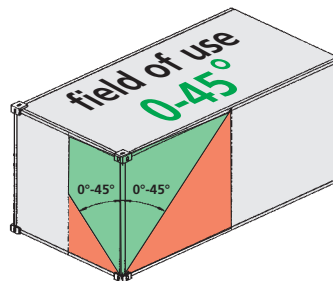
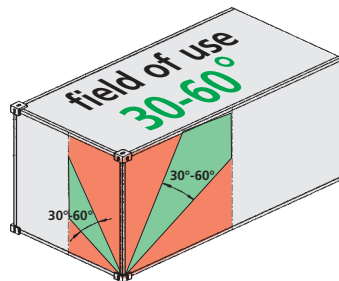
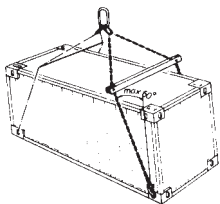
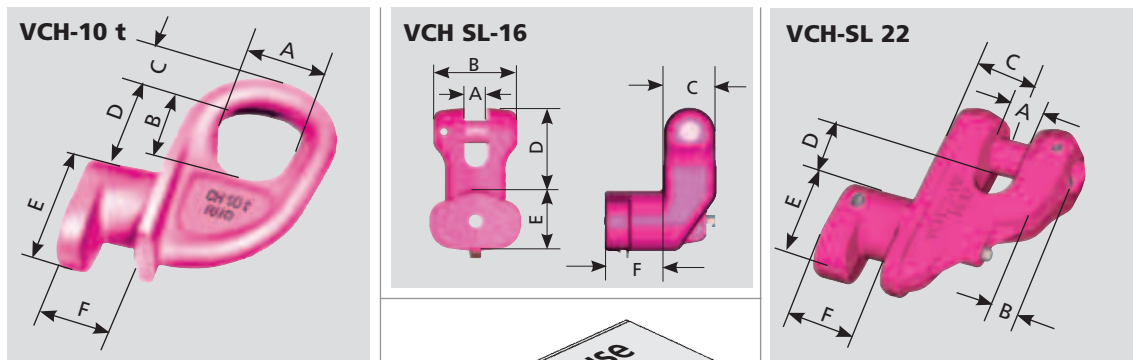

VCH - 10 t suitable for ISO container edges. Fix connection by VVS or VVGSCB. Loose component for hook mounting.

Suitable for ISO-Container edges. The container hook is equipped with a patented securing device. Therefore the hook cannot fall out of the ISO edge. Easy handling. **Inserting:** Without operating of securing device. **Taking out:** Only possible when locking pin is released. RUD VCH-SL hooks are suitable for vertical lifts and up to max. 45° inclination angle (see graphic chart). Clevis connection suits 16 mm VIP chain.

VCH - SL 22 suitable for ISO container edges. Clevis connection for the 22 mm VIP chain. VIP chain size can be reduced to 16 mm when using a VRG-16 connector.

With patented locking mechanism.

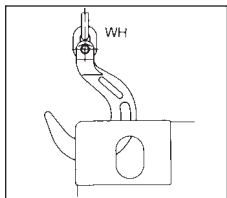

For 1D, 1E and 1F Containers (< 9 ft), they can be lifted by the upper corner edge with a 4-leg sling chain with a maximum inclination angle of 30°.

Type	WLL t	A	B	C	D	E	F	kg/pc.	Ref. No.
VCH - 10 t	10.0	56	70	24	83	76	45	3	51 005
VCH - SL 16	10.0	18	71	42	40	50	47	2.5	85 03 115
VCH - SL 22	20.0	24	62	48	45	76	45	4.2	85 02 313

- The all-purpose robust connecting link
- Lifting points, shackles and plate clamps can be attached into the halves of the connecting link.
- Form and kinking free function are patent pending
- No kinking of pre-assembled chain possible.
- The halves are exchangeable between each other.
- No movement of securing pin and therefore no damage of the common securing springs or -sleeves.

⊛ **Patented wear markings** are showing the moment of replacement acc. To BGR 500, Chapter 2.8 without the necessity of measuring.

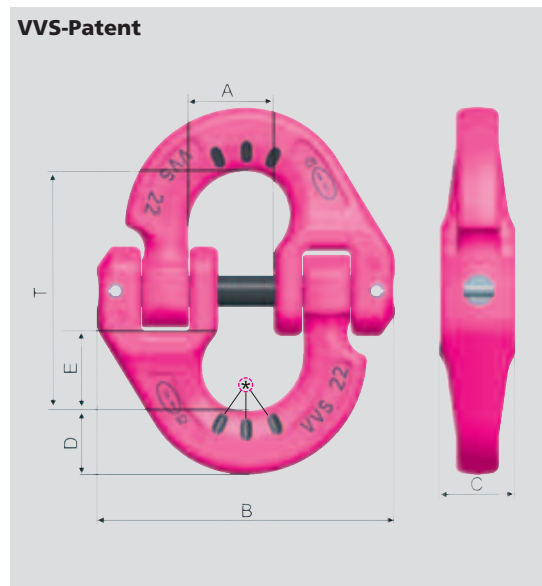

VIP-Connecting link VVS-Patent

World champion in load capacity!

Type	WLL t	A [mm]	B [mm]	C [mm]	D [mm]	E [mm]	T [mm]	Weight kg/pc.	Ref. No.
VVS 6	1.5	18	55	13	11	17	46	0.12	79 01 438
VVS 8	2.5	24	70	18	14	23	61	0.29	79 01 439
VVS 10	4.0	28	88	22	17	27	74	0.57	79 01 440
VVS 13	6.7	34	111	28	23	33	93	1.2	79 01 441
VVS 16	10.0	39	130	33	27	37	108	2.0	79 01 442
VVS 20	16.0	42	154	41	34	41	124	3.7	79 01 443
VVS 22	20.0	48	172	44	37	46	138	4.8	79 01 444
VVS 28	31.5	69	228	58	47	67	189	10.6	79 01 445

VERG to be used as a plug-in bolt for transportation of tools and other similar lifting purposes when bores are the only specified lifting points available.

Minimum diameter D, refer to the table, minimum bolt length L is 2 x D. Maximum diameter D = 48 mm. Bore diameter = D + 1 mm. We recommend that for vertical lifting purposes, the VERG should be used with a spreader bar or a cross beam.

Attention:

In the event of any lifting procedure, attachment should always be at the collar. The plug-in connectors are non stock items and their production is subject to customer requirement. Thus bear in mind the respective delivery periods.

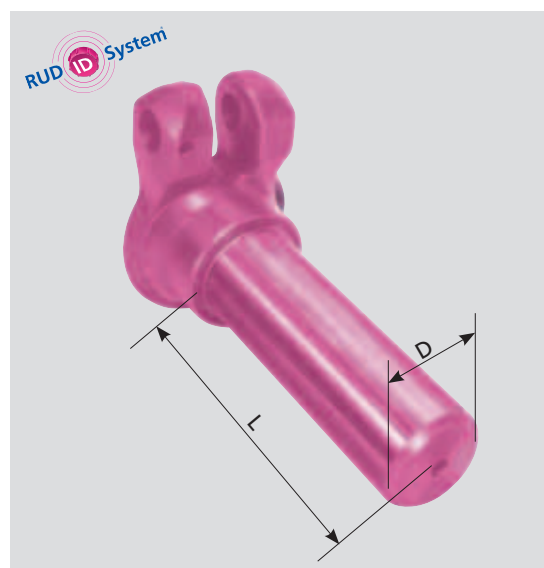
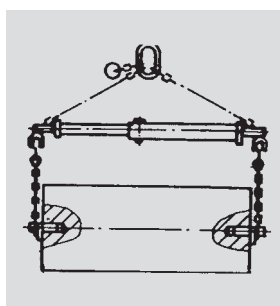

VIP-Plug-in connector VERG

Chain	WLL t	Type	D _{min}	D*	L*	A _{min.}	T
6	1.5	VERG – 6	17			11	20
8	2.5	VERG – 8	22			15	26
10	4.0	VERG – 10	28			18	33
13	6.7	VERG – 13	36			24	42
16	10.0	VERG – 16	45			29	54

Indicate sizes L and D when ordering!

Subject to technical modifications!



Endless chain ICE-120 and VIP-100 with compact connecting-elements



Endless chain with H-Connector

VIP VKR-H	Ø 6 mm	Ø 8 mm	Ø 10 mm	Ø 13 mm	Ø 16 mm
Edless chain sling in choke hitch	2.4	4.0	6.4	10.6	16
0-45°	1.65	2.75	4.4	7.5	11.0
	45-60°	1.2	2.0	3.2	5.3
ICE IKR-H	Ø 6 mm	Ø 8 mm	Ø 10 mm	Ø 13 mm	Ø 16 mm
Edless chain sling in choke hitch	2.88	4.8	8.0	12.8	20.0
0-45°	2.0	3.3	5.5	8.8	14.0
	45-60°	1.44	2.4	4.0	6.4

* For extreme abrasive usage we recommend to use ICE chains

WLL in [t]

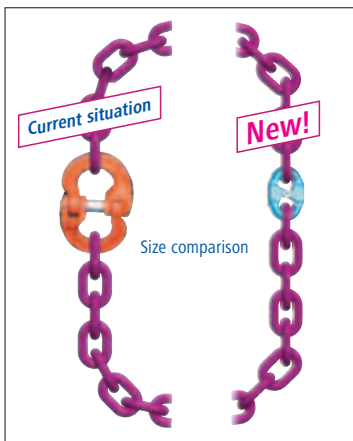

Endless chain with Dominator

VIP VKR-D	Ø 20 mm	Ø 22 mm	Ø 28 mm
Edless chain sling in choke hitch	25.6	32.0	50.0
0-45°	17.6	22.0	35.5
	45-60°	12.8	16.0

WLL in [t]

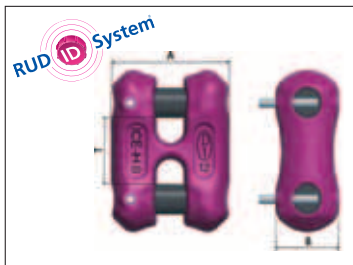

H-Connector (ICE and VIP)	chain	A [mm]	B [mm]	T [mm]	weight [kg/pc.]	Ref.no.
IH-6/VH-6	6	34	19.6	18	0.11	7901922
IH-8/VH-8	8	45	25.5	18	0.11	7901453
IH-10/VH-10	10	56	31.5	30	0.55	7901454
IH-13/VH-13	13	73	40	39	1.16	7901455
IH-16/VH-16	16	89	49	48	2.16	7901924

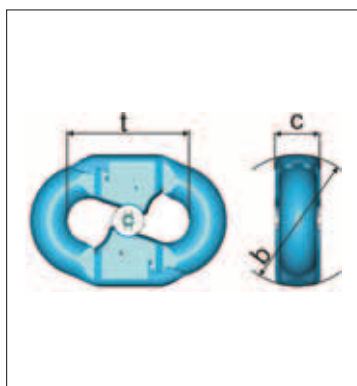

Dominator (VIP)	For chain Ø [mm]	WLL [t]	A [mm]	B [mm]	T [mm]	weight [kg/pc.]	Ref.no.
Dominator 22 x 86 for VIP 20 x 60	20	16	85	26	86	1.2	56295
Dominator 26 x 92 for VIP 22 x 66	22	20	95	33	92	1.8	58915
Dominator 34 x 126 for VIP 28 x 84	28	31.5	119	40	126	4.1	58917

Subject to technical modifications!

Exact length adjustment for chain assemblies

Length of chains can be adjusted precisely by right and left hand drive thread with a toggle (ICE-CURT-GAKO) or with a ratched (VLE).

Adjustment is only permitted in unloaded condition.

ICE-CURT-K-GAKO*-components replace the current VKSPS models.

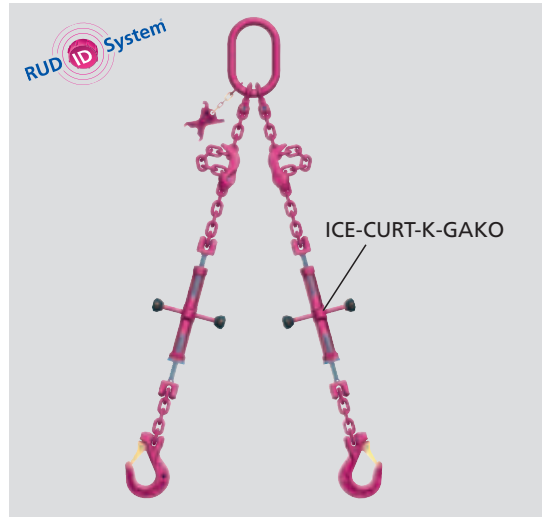
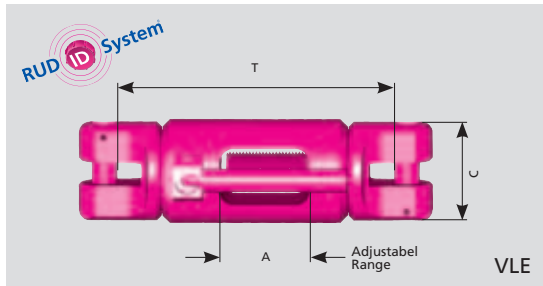

ICE-CURT-K-GAKO

VLE

Chain Ø	Type	WLL lifting [t]	Adjustabel Range [mm]	C [mm]	Tmin [mm]	Ref. no.
6	ICE-CURT-K-6-GAKO*	1.8	140	–	260	7904448
8	ICE-CURT-K-8-GAKO*	3.0	170	–	350	7904449
10	ICE-CURT-K-10-GAKO*	5.0	170	–	362	7904450
13	ICE-CURT-K-13-GAKO*	8.0	300	–	530	7904451
16	ICE-CURT-K-16-GAKO*	12.5	350	–	612	7904452
20	VLE 20	16.0	140	110	363	7997322
22	VLE 22	20.0	140	110	363	7994668
28	VLE 28	31.5	175	138	478	790772

Force balancing lifting of loads

- f.e. erecting of tower segments of wind towers
- Pentagon shaped wheel for the deviation of chains
- Ballbearing suspension for shackles
- Small size
- connection with high tensile shackles
- Replaces wire rope snatch blocks
- Decelerated Pentagon wheel to avoid that chains runs to one side when no load is applied.

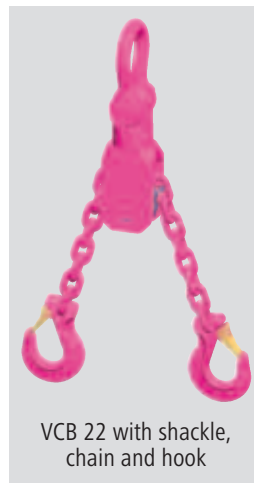

VCB 22 with shackle, chain and hook



VIP Chain block

RUD ID System

We'll kindly consult you with your lifting needs!

Chain Ø	Type	WLL lifting [t]			Thickness C [mm]	Connection on top		pitch [mm]	Weight [kg/pc.]	Ref. no.
		0-7°	7-20°	20-45°		bore dia. Ø D [mm]	Connecting element			
16	VCB-16	20	18.5	14	50	45	VV-GSCH-22	approx. 210	25	7903925
22	VCB-22	40	37.5	28	80	68	Bow shackle 42.5 t	approx. 285	56	7900835

Subject to technical modifications!



33% higher WLL!

VW – VIP-Balancer

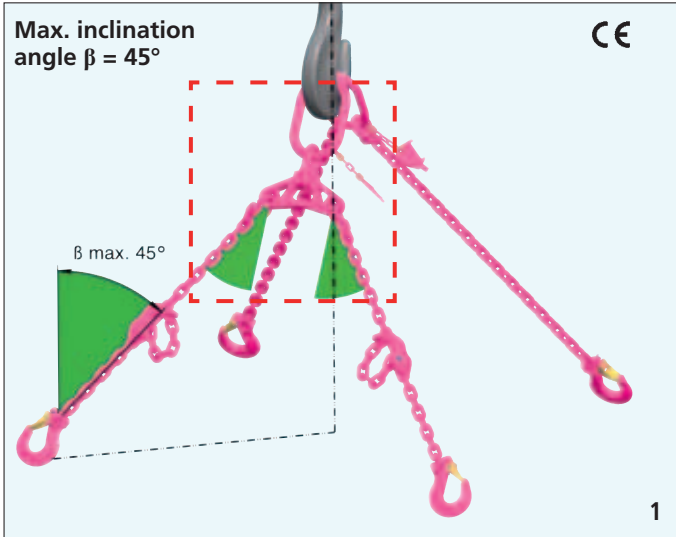

- When using the VIP assembly with Balancer, you have to consider the following:
- The load has to be symmetrical
 - The inclination angle β must not be beyond 45° (see graphics 1 and 2)
 - The inclination position of the balancer must not exceed 10° (see graphics 3, 4 and 5)
 - For detailed information on the VIP-Balancer, please refer to operation manual

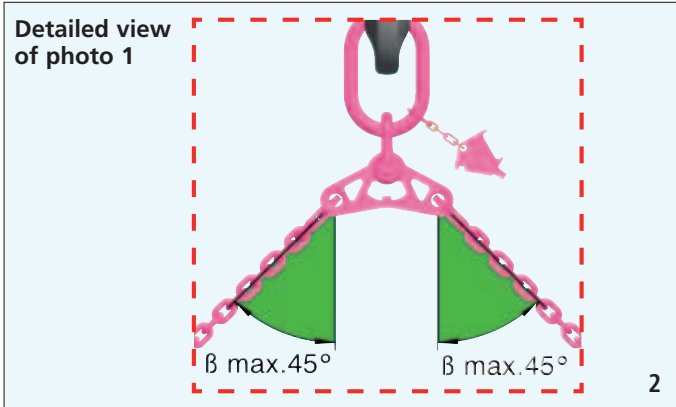

With a 4-leg assembly, maximum 3 legs can be considered as bearing only, in unfavourable cases 2 ones only
Our advice:
 By using the VIP 2x2 assembly with Balancer in the shown configuration the **load will equally be distributed** to all 4 legs, resulting in a **33 % increased WLL** compared with a standard 4-leg assembly (refer to table).

Comparison VIP 4-leg assembly / VIP 2x 2-leg assembly with balancer

Chain [mm]	WLL VIP 4-leg assembly 0-45°	WLL (t) VIP 2x2-leg assembly with balancer up to angle $\beta = 45^\circ$
6	3.15	4.2
8	5.25	7.0
10	8.4	11.2
13	14	19.0
16	21	28.0
20	33.6	45.0
22	42	56.0

For higher WLL's with angle $\beta = 15^\circ$ or $\beta = 30^\circ$, please refer to operation manual.
Attention: The 2-leg assembly with balancer must not be used as 2-leg assembly in stand-alone version. Any working means used for lifting of loads have to avoid that the load may unintentionally shift in a dangerous way (see BetrSichV, annexe 1, parag. 3.2.3).

In case of unsymmetrical loads, please contact the manufacturer. We will always be prepared to assist you!

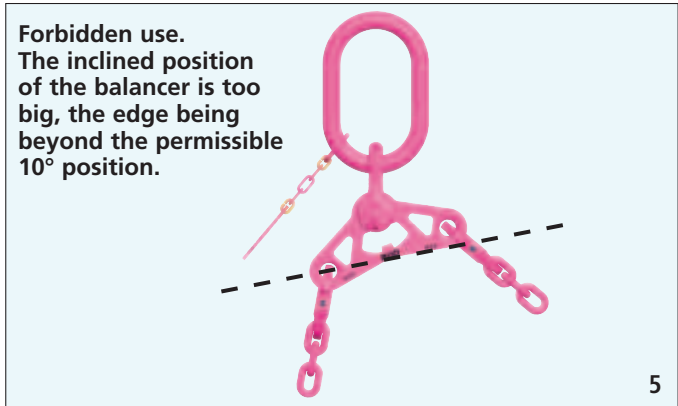
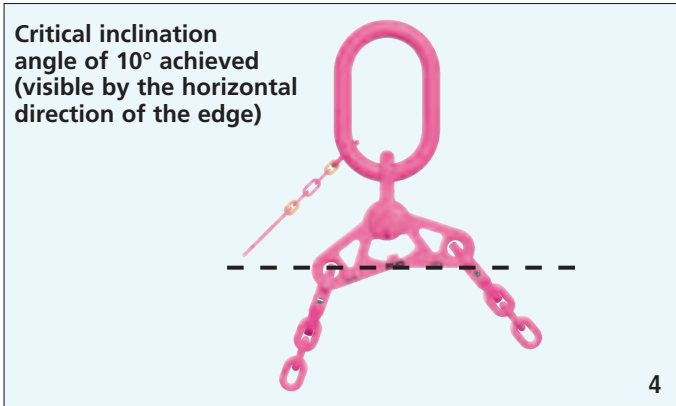
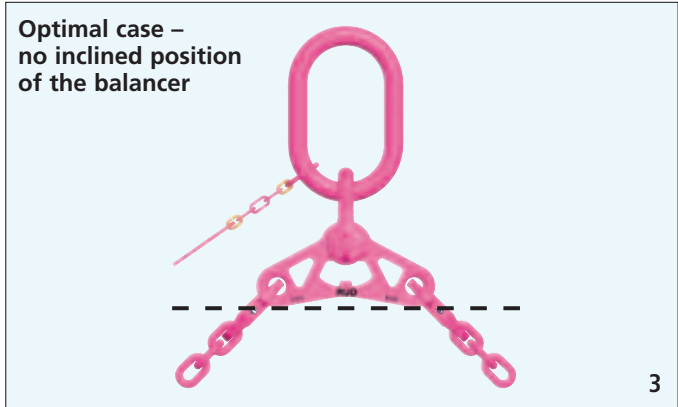

Assembly of VIP-Balancing head VWK-2S

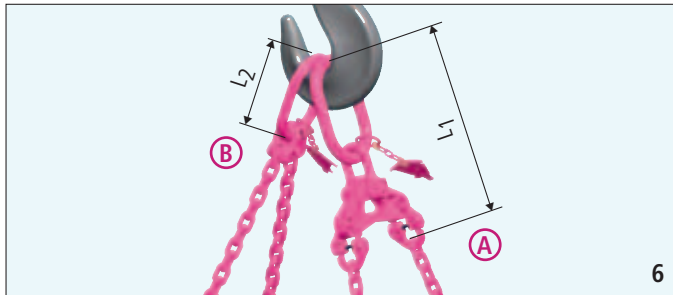

The VIP-Balancer head VWK-2S (A) comprises:

- VA link with identification tag
- VIP shackle
- VIP-Balancer
- 2 VIP-Connecting links

Chain [mm]	Type VIP-Balancer head (A)	Sizes VAK and VA link [mm]	Connection at top	Connection at bottom	Pitch of balancer head L1 [mm]	Weight of balancer head [kg/pc.]	Art. No. VIP-Balancer head
6	VWK-2S-6	18 x 75 x 135	VV-SCH10 (4t)	VVS 6	276	1.95	7904502
8	VWK-2S-8	22 x 90 x 160	VV-SCH13 (6.7t)	VVS 8	343	3.99	7904503
10	VWK-2S-10	26 x 100 x 180	VV-SCH16 (10t)	VVS 10	403	7.35	7904504
13	VWK-2S-13	32 x 110 x 200	VC-SCH 4.0 (14t)	VVS 13	475	13.42	7904505
16	VWK-2S-16	36 x 140 x 260	VC-SCH 5.0 (22.4t)	VVS 16	599	23.53	7904506
20	VWK-2S-20	51 x 90 x 350	VC-SCH 6.0 (31.5t)	VVS 20	717	35.32	7904507
22	VWK-2S-22	51 x 90 x 350	Shackle (40t)	VVS 22	823	49.98	7904508

Chain [mm]	Type VIP 2-leg master link for assemblies with balancer (B)	Sizes VAK and VA link [mm]	Pitch 2-leg VAK L2 [mm]	Weight 2-leg VAK [kg/pc.]	Art. No. 2-leg VAK
6	VWK 2S-6	18 x 75 x 135	217	1.36	7904509
8	VWK 2S-8	22 x 90 x 160	268	2.4	7904510
10	VWK 2S-10	26 x 100 x 180	311	4.0	7904511
13	VWK 2S-13	32 x 110 x 200	373	6.9	7904512
16	VWK 2S-16	36 x 140 x 260	470	11.5	7904513
20	VWK 2S-20	51 x 90 x 350	614	32.8	7904514
22	VWK 2S-22	51 x 90 x 350	644	35.0	7904515

VW – VIP-Balancer

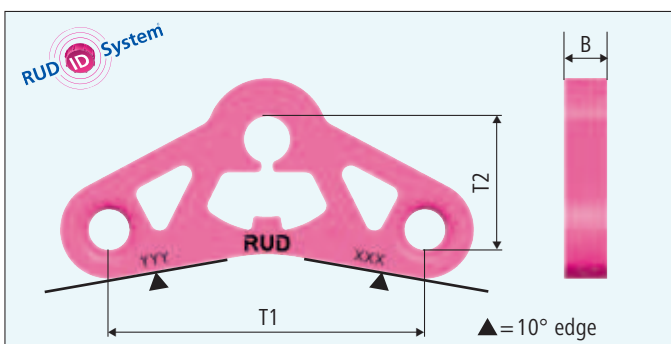

- Connection for balancer at top: connection by shackle
- Connection for balancer at bottom: VIP-Connectors
- Easy visibility of the critical inclined position of 10° by the special shape at the bottom side of the balancer
- Powder coated in VIP pink
- For detailed information regarding the VIP-Balancer, please refer to the operation manual
- Including RUD-ID-Point®.

Chain [mm]	Type	WLL balancer 0-45°	T1 [mm]	T2 [mm]	B [mm]	Weight [kg]	Art. No.
6	VW-6	2.1	110	46 (42)	15	0.49 (0.4)	7904366 (7983128)
8	VW-8	3.5	150	59 (56)	20	1.15 (1.0)	7904369 (7983129)
10	VW-10	5.6	180	76 (70)	25	2.4 (2.2)	7904371 (7983130)
13	VW-13	9.5	240	91 (97)	30	4.37 (4.1)	7904374 (7982669)
16	VW-16	14.0	300	120 (120)	35	8.8 (8.1)	7904254 (7983131)
20	VW-20	22.4	300	123 (123)	45	10.7 (12.4)	7904725 (7983135)
22	VW-22	28.0	350	138 (138)	50	15.4 (17.1)	7904726 (7983142)

Subject to technical modifications!

Values in brackets () = deviating values of the former VIP balancer





**VIP-
Overload
indicator
complete
VCG**

**Unique
RUD
product!**

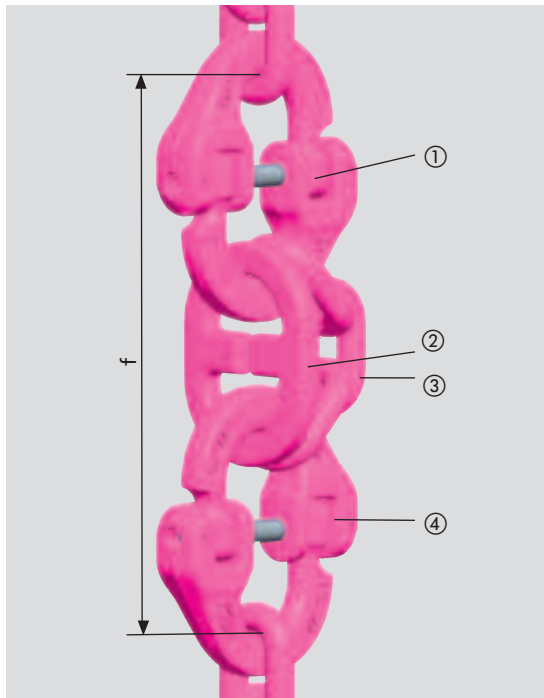

The safety sensation

Immediate visual indication of overload - due to the specially calibrated RUD control link VCG. Although stationary fitted it can easily be replaced by means of the **Combi-lock VVS** consisting of:

- ① **Combi-lock VVS-U** (see page 27) Easy hammer mounting (fool-proof chain connection)
- ② **Control link VCG** With indicator bars and a calibrated slot width (nominal... mm)
- ③ **VIP chain, 3 links** (see page 8) Additional securing element besides the control link in side connection
- ④ **Combi-lock VVS** (see page 27) Easy assembly (fool-proof chain connection)

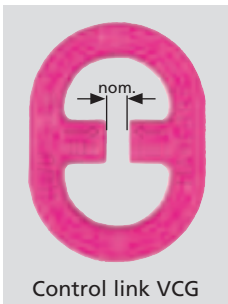

Control link VCG

Control link VCG

Type	WLL t	Initial size nom. (mm)	Weight kg	Ref. No.
VCG - 6	1.5	4	0.06	79 87 623
VCG - 8	2.5	6	0.10	79 87 046
VCG - 10	4	7	0.20	79 87 626
VCG - 13	6.7	10	0.40	79 88 245
VCG - 16	10	11	0.70	79 89 743
VCG - 20	16	12	1.10	79 92 549
VCG - 22	20	16	1.90	79 92 551

Overload indicator VCG (complete)

Nom. size chain mm	WLL t	single parts	build. length (mm)	Weight kg
6	1.5		115	0.3
8	2.5	VVS	151	0.5
10	4	VCG	198	1.2
13	6.7	3 links	232	2.1
16	10	Chain	291	4.5
20	16	VVS	345	8.8
22	20		382	12.1

Hints for use

Immediate visual indication of overload – due to the specially calibrated RUD control link VCG.

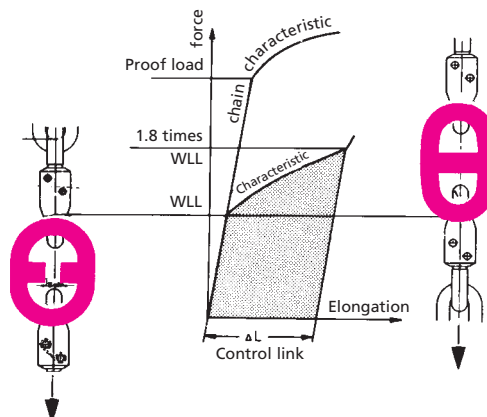

Do not exceed permissible WLL!
The calibrated slot width corresponds with the indicated nominal size.

Chain strand overloaded!
Clearly visible through the indicator. **Slot width will decrease** with increasing overload. The closing of the indicator implies that the WLL has been exceeded by 80 % to 100 %!

If the two indicator bars are not closed after overload (slot width > 0.5 mm), the user may install a new control link. Should the overload repeatedly occur, a bigger chain size has to be used. If the bars are closed or even bent up, the chain has to be removed from operation and be examined (as per BGR 500).

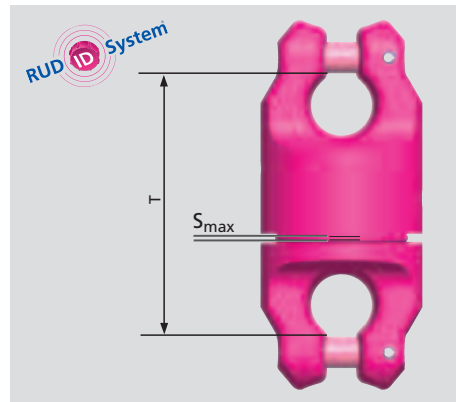

**VIP-
Universal
Swivel
-PP-UW-
Patent**

The following applies to both versions:

The BGR stipulates that twisted slings are not to be loaded. This requirement is automatically achieved by the ball bearing swivel - swivelling under load.

Not designed for continuous use.

Special universal swivel PowerPoint:

A patented clevis connection design hence a universal connection which is loadable from any direction and facilitates the shortest combination possibilities.

Only RUD-approved VIP chains and components must be used.

1. VIP Cobra-Eye Hook VCÖH, see page 18
2. B-Link for PowerPoint PP-(WLL)-B, see page 13

Note: VIP chain connection is designed fool proof. When assembling component 1 and 2, please pay attention to the correct Working Load Limits.

Special VWA:

Due to the adapter bar, it can be fool-proof connected to all VIP clevis components. The sealed body makes it more resistant to dirt. Do not bend the appliance! The installation of the adapter should be done in such a way that no bending occurs during use. Supply is subject to stock availability. This type will soon be replaced.

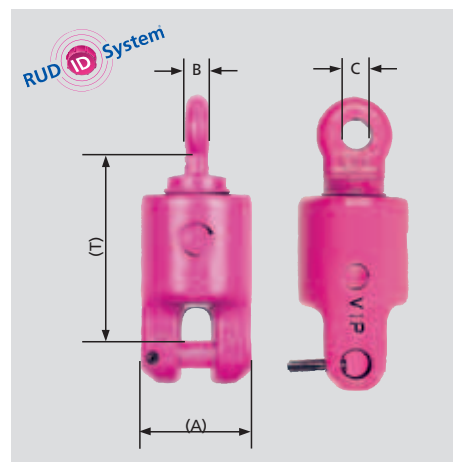

**VIP-
Swivel
connector
VWA**

Chain	WLL t	Type	A	B	C	T	S _{max}	kg/pc.	Ref. No.
4	0.63	UW-PP-4	32	4.8	13	56	4.5	0.20	79 90 878
6	1.5	UW-PP-6	38	7.0	16	68	4.5	0.42	79 90 879
8	2.5	UW-PP-8	52	9.1	20	88	6.0	1.0	79 90 880
10	4.0	UW-PP-10	66	11.0	26	106	6.0	1.9	79 90 881
13	6.7	UW-PP-13	80	14.4	30	131	6.5	3.6	79 90 882
16	10.0	UW-PP-16	86	17.6	37	141	8.0	4.9	79 92 861
20	16.0	VWA-20	100	21	25	147	-	6.7	79 90 723
22	20.0	VWA-22	102	23	28	147	-	6.8	71 00 634

A single component for extrinsic connections to clevises, flanges etc.

Complete with a pre-assembled connecting bolt and tensioning sleeve.

Chain	WLL t	Type	A	B	C	D	E	T	kg/pc.	Ref. No.
6	1.5	VRG 6	17	30	37	16	8	28	0.07	71 00 469
8	2.5	VRG 8	23	40	50	22	10	37	0.2	71 00 470
10	4.0	VRG 10	28	50	60	26	13	46	0.3	71 00 471
13	6.7	VRG 13	36	64	75	32	17	58	0.7	71 00 472
16	10.0	VRG 16	45	75	92	40	20	74	1.1	71 00 473
20	16.0	VRG 20	58	92	118	52	28	94	3.1	71 03 384
22	20.0	VRG 22	62	102	124	52	32	94	3.5	71 01 611

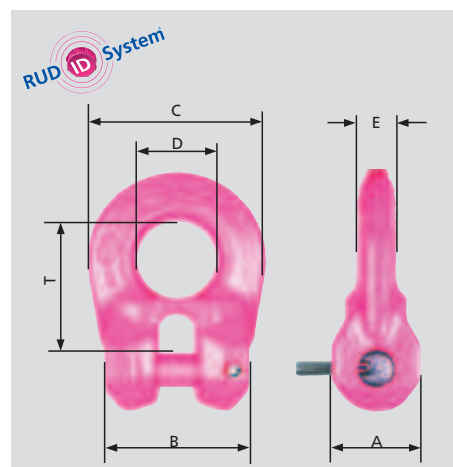

**VIP-
Connector
VRG**

Subject to technical modifications!





Examples of applications

Order references

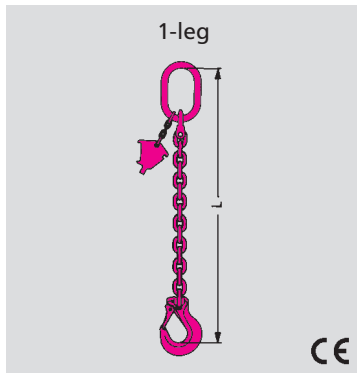

Order reference:
VIP-G1...

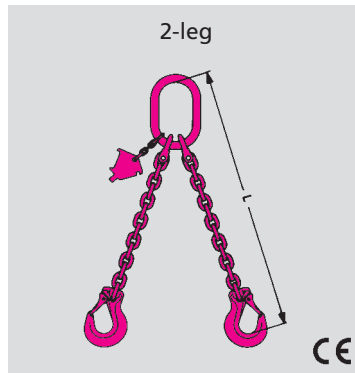

VIP-G2...

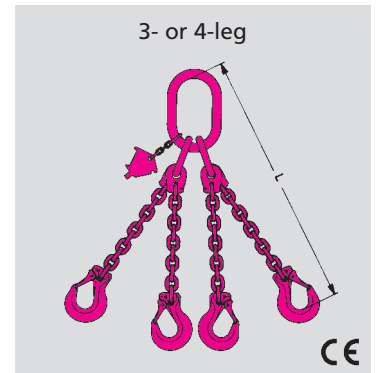

VIP-G3...
or VIP-G4...

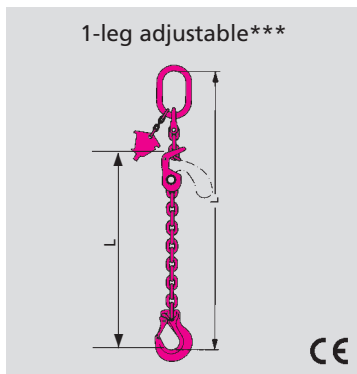

Order reference:
VIP-G1-V1...

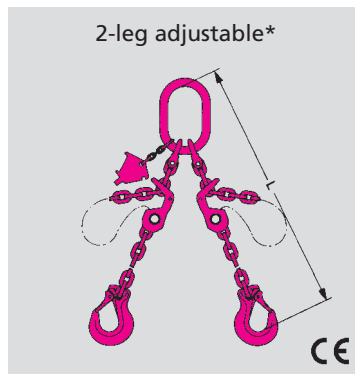

VIP-G2-V2...

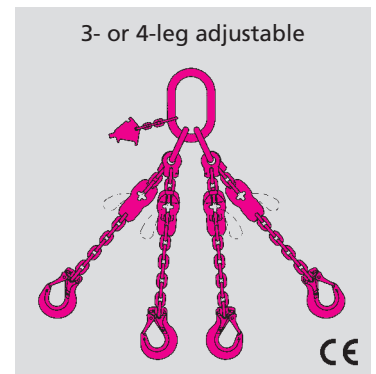

VIP-G3-V3...
or VIP-G4-V4...

Combination possibilities

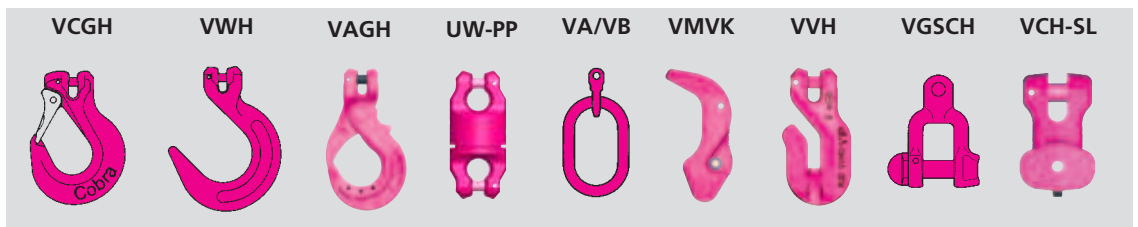

Order reference:

*VIP-G2-V2-VCGH/10x2000

= 2 leg version in RUD special quality VIP with 2 leg shortenings (VMVK).

VCGH = End component/10 = chain diameter x 2000 = max. working length size L in mm.

Assembled endless chain

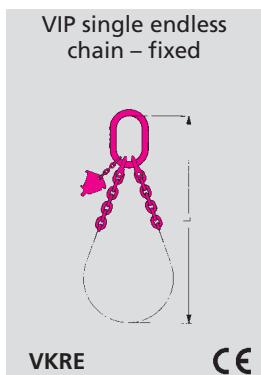
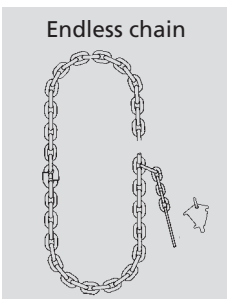

VKRE

CE

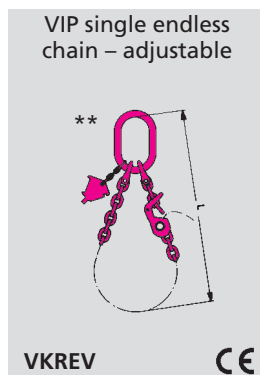

VKREV

CE

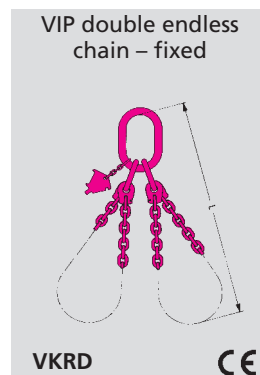

VKRD

CE

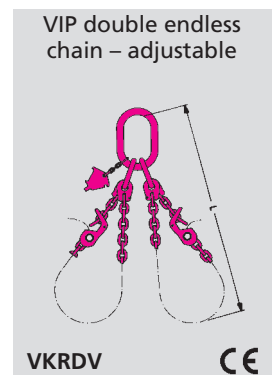

VKRDV

CE

Order examples:

**1 pc VKREV-8 x 2000 = single endless chain, adjustable in RUD special quality VIP, 8 = chain dia. x 2000 = max. working length size L in mm.

*** in case of long adjustable assemblies it is recommended to mount the multi claw VMKV in the lower part of the chain. Indicate Lv when ordering, e.g. VIP-G2-V2-VCGH/10x5000 Lv-2000.

special connecting link*
for VIP-endless chain:
Ø 20, 22 und 28 mm.
On request.

A WORLD SPECIALTY-

the one and only Mini mecano system 4 mm!



Mecano „in miniature“ for small loads up to 1320 kg!



VIP chain assembly, fixed length

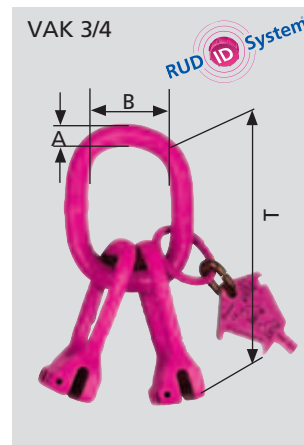
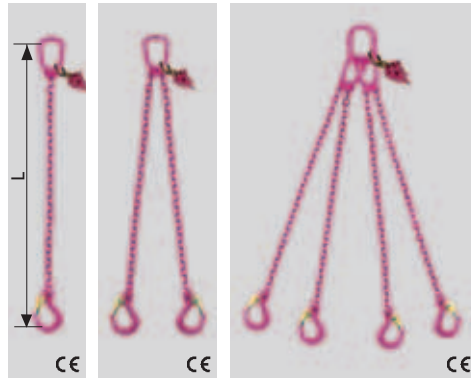

VIP-
Master link
VAK 1/2

VIP-
Master link
VAK 3/4

Chain	WLL t	Type	A	B	T	Weight/kg	Ref. No.
4	0.63	VAK 1/2 – 4	9	30	55	0.1	79 84 445
4	1.32	VAK 3/4 – 4	10	35	106	0.3	79 84 447

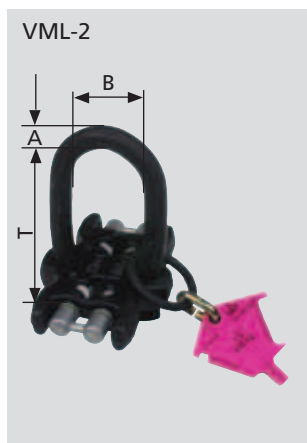

VIP chain assembly, can be shortened

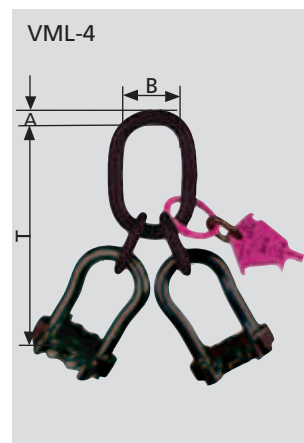
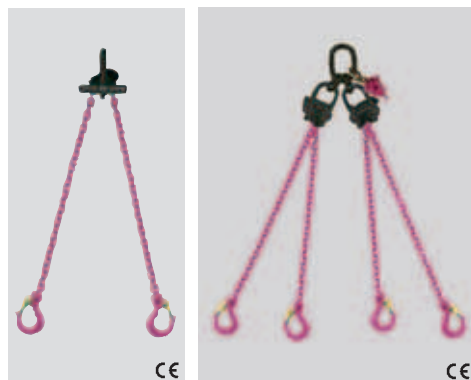

VIP-
Mini-lifter
VML-2
– complete
with
shorteners –
»patent«

VIP-
Mini-lifter
VML-4

Chain	WLL t	Type	A	B	T	Weight/kg	Ref. No.
4	0.88/0.63	VML 2 – 4	10	30	66	0.26	79 84 478
4	1.32/0.95	VML 4 – 4	10	35	150	0.85	79 84 479

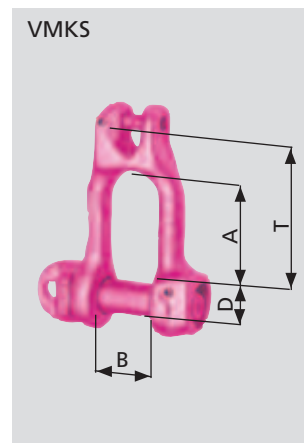
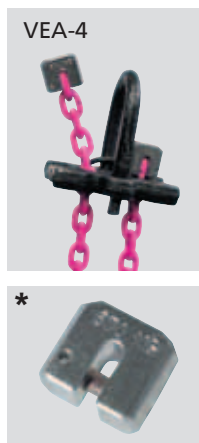
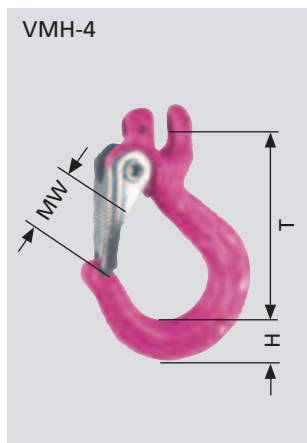

VIP-
Mini-hook
VMH-4

*VIP-
End link
VEA-4!

VIP-
Mini-
coupling
shackle
VMKS

Chain	WLL t	Type	MW	A	B	T	D	H	Weight/kg	Ref. No.
4	0.63	VMH – 4	18	-	-	56	-	13	0.12	79 84 439
4	0.63	VMKS – 4	-	30	14	42	10	-	0.12	79 85 243
4	0.63	VEA – 4	-	-	-	-	-	-	0.05	79 90 215

Subject to technical modifications!



The Heavy Duty Solution



- For the safe lift of heavy loads
- Adjustable, edge wear resistant
- Divisible, but lockable chain sling

Chain 28 x 84 Grade 100
For loads up to 126 t

MAXI

Chain length can be easily adjusted manually

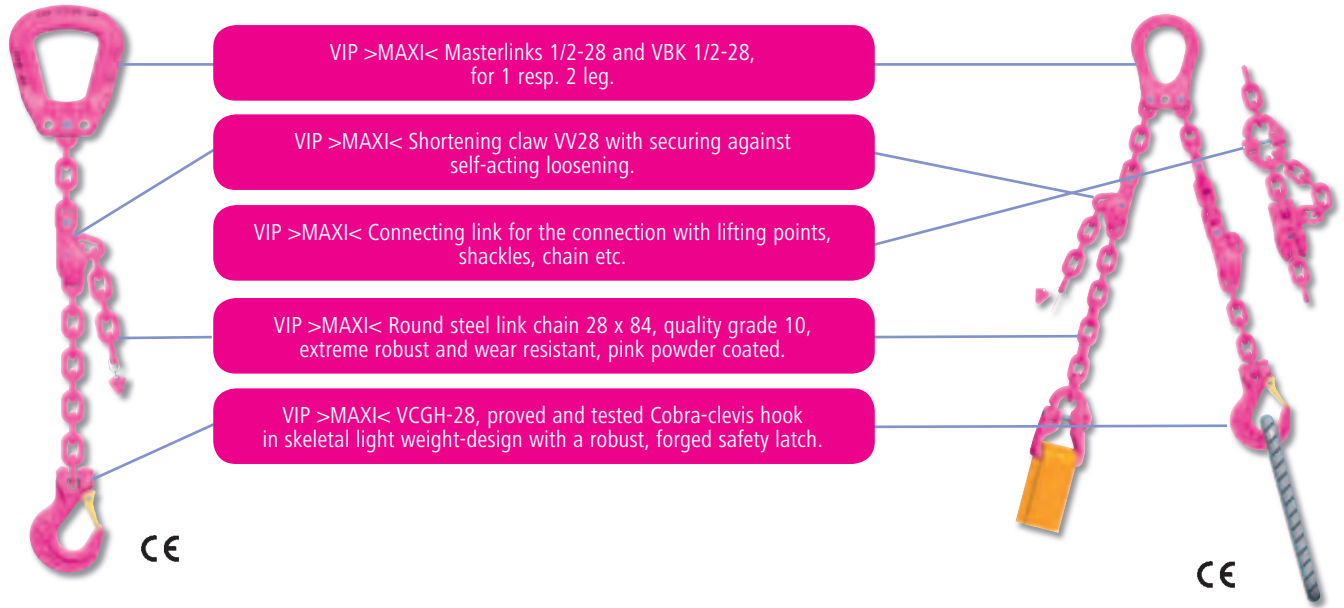

VAK-1/2-28*	VBK-1/2-28**	VB-28	VCGH-28
VVS-28	VW-28	RS-VVS-28	VIP-Domi
VLE-28	VUW-28***	VUW-GLD-28***	Combination VVS-28 and VC-SCH 6.0 with VIP-chain 28x84
VIP-Chain 28x84	VC-SCH-6,0	VIP-KZA + MAXI gauge	RUD ID System

* VAK 1/2-28: For single crane hooks (Size 40+50) and double crane hooks (Size 40+50)

** VBK 1/2-28: For single crane hooks (Size 12-32) and double crane hooks (Size 12-32)

*** In preparation

■ For details regarding MAXI lifting points please see the MAXI flyer

Nomination	WLL [t]	A [mm]	B [mm]	C [mm]	D [mm]	E [mm]	F [mm]	G [mm]	T [mm]	Weight [kg/pc.]	Ref.-No.
VAK-1/2-28	31.5/45/63	100	250	280	208	120	76	-	360	64.3	7900642
VBK-1/2-28	31.5/45/63	60	190	265	240	120	55	-	322	35	8504022
VB-28	31.5	62	130	150	130	80	100	52	209	13.7	7900641
VCGH-28	31.5	150	101	69	88	-	90	295	275	26.4	7900638
VVS-28	31.5	69	228	58	47	67	81	-	189	10.6	7901445
VV-28	31.5	150	130	130	-	-	-	-	170	16.9	7900643
RS-VVS-28	31.5	69	163	100	47	33	-	-	245	20	7903511
VIP-DOMI	31.5	-	-	40	-	-	-	-	126	4.1	58917
VLE-28	31.5	650	172	138	120	-	-	-	478	44	7900772
VUW-28***	31.5	148	-	-	-	-	-	-	183	27.3	7903435
VUW-GLD-28***	31.5	153	-	-	46	110	169	-	416	32.1	7903436
Kombi VVS-28 and VC-SCH 6.0	31.5	-	-	-	-	-	-	-	309	16.5	-
VMK 28x84	31.5	28	37	-	-	-	-	-	84	18.6	7900670
VC-SCH 6.0	31.5	53	34	78	39	37	34	121	120	5.9	7984333
ABA 31.5	31.5	108	64	320	130	50	204	-	154	18.3	7902175
VRBS-FIX 31.5	31.5	160	42	99	130	366	195	-	202	18.4	7999302
WPPH-KA-28***	31.5	28	-	-	148	-	-	-	74	11	7903438
VWBS-KA-28***	31.5	28	-	-	170	-	-	-	147	24	7903440
VWBS 40 t (50 t)	40	46	170	110	170	-	-	161	380	27.9	7903650
VWBG-KA-28***	31.5	-	-	-	170	-	108	-	146	26.4	7903437
VWBG 31.5	31.5	46	130	90	170	-	108	159	338	29.9	7900097
VRBG 31.5	31.5	180	42	-	130	-	-	400	-	67.0	7985866

*** in preparation

WLL for symmetrical loads

inclination angle β	0°	0°	0-45°	>45-60°	0-7°	>7-45°	0-45°
load factor	1	2	1,4	1	4	2,8	2,1
WLL [t]	31,5	63,0	45,0	31,5	126	88	67,0
inclination angle β	0-7°	>7-45°	>45-60°	0-7°	>7-45°	0-7°	>7-45°
load factor	2	1,4	1	4	2,8	4	2,8
WLL [t]	63*	45,0*	31,5*	126*	88*	126*	88*



Important hints:

- At unsymmetrical loads the WLL must be reduced by 50 %.
- *Choke hitch or endless chains:
With bits, bolts, resp. diameter of shackle pin > 3 x t (250 mm) the WLL of a double strand can be assumed.
With smaller diameters (loading at the edge) the WLL must be reduced by 20 %.
- If double strand is required please specify

! When using a basket hitch it must be guaranteed that loads cannot shift into dangerous positions or drop (BetrSichV, Attachment 1 acc. to § 7).





**VIP-
Spreader
bar fixed
VSRS**

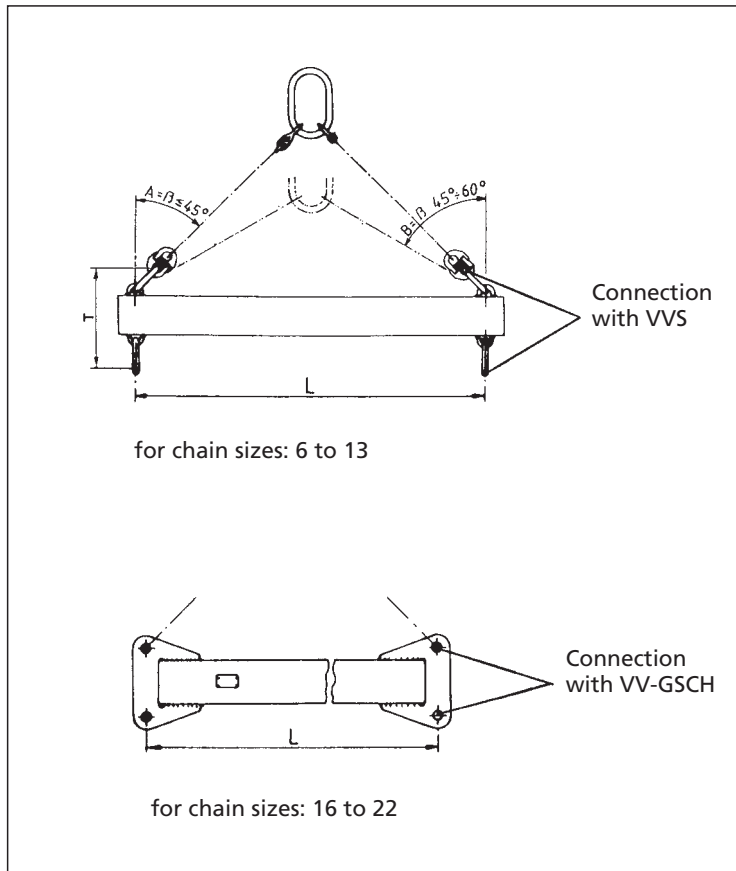

VIP Spreader bar fixed VSRS
When ordering please indicate the effective length L of the spreader bar!

Spreader bars are also available with chain slings. When ordering, specify the type of master link and the required inclination angle β .

VIP spreader bars are non stock items and their production is subject to customer requirement. Thus bear in mind the respective delivery periods.

Surface:
Effective length L up to 2500 mm: pink powder coated.

Effective length L beyond 2500 mm: yellow painted.



Chain size	Type	Possible working length L	T	WLL kg		Weight kg/pc.	Ref. No.
				0 – 45°	45 – 60°		
6	VSRS-6	500 – 4000 mm	190	2100	1500	depending on working length L	86 00 110
8	VSRS-8	500 – 5000 mm	240	3500	2500		86 00 111
10	VSRS-10	500 – 5000 mm	320	5600	4000		86 00 112
13	VSRS-13	1000 – 5000 mm	350	9500	6700		86 00 113
16	VSRS-16	1000 – 5000 mm	250	14000	10000		86 00 114
20	VSRS-20	1000 – 5000 mm	285	22400	16000		86 00 115
22	VSRS-22	1000 – 5000 mm	290	28000	20000		86 00 116

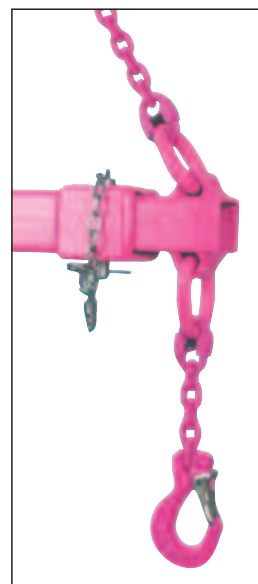

Subject to technical modifications!

VIP Spreader bar adjustable VSRV

When ordering please indicate working length L of the spreader bar!

Adjustable spreader bars are also available with chain slings. When ordering, specify the type of master link and the required inclination angle β .

VIP spreader bars are non stock items and their production is subject to customer requirement. Thus bear in mind the respective delivery periods.

Surface:
Pink powder coated.

L_{min} . depends on
 L_{max} . and nominal size.

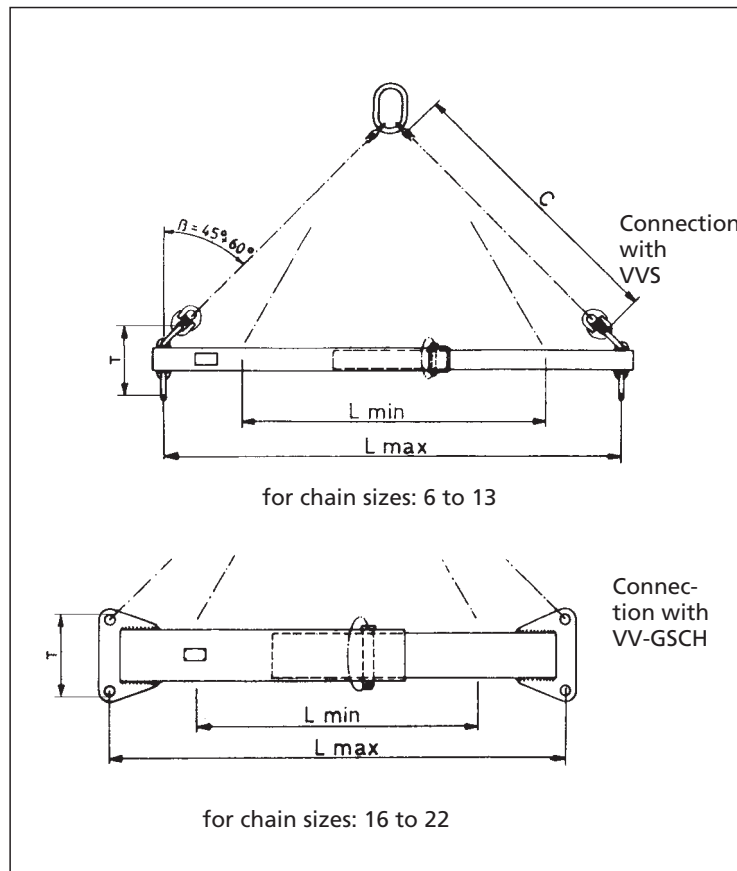

VIP-Spreader bar adjustable VSRV

Chain size	Type	possible working length L_{max} .	T	WLL kg		Weight Kg/St.	Ref. No.
				$\leq \beta 45^\circ$	$\beta 45 - 60^\circ$		
6	VSRV-6	1500 – 4000 mm	200	2100	1500	depending on working length L	86 00 120
8	VSRV-8	1500 – 4000 mm	250	3500	2500		86 00 121
10	VSRV-10	1500 – 4000 mm	330	5600	4000		86 00 122
13	VSRV-13	1500 – 4000 mm	360	9500	6700		86 00 123
16	VSRV-16	1500 – 4000 mm	250	14000	10000		86 00 124
20	VSRV-20	1500 – 4000 mm	285	22400	16000		86 00 125
22	VSRV-22	1500 – 4000 mm	290	28000	20000		86 00 126

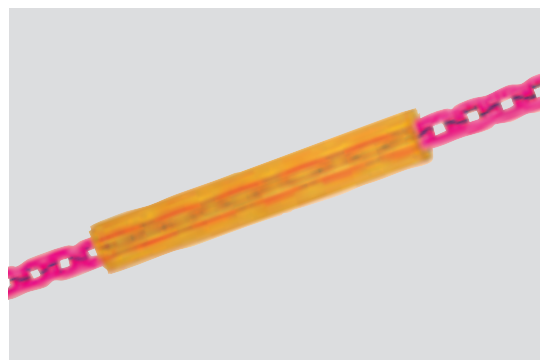
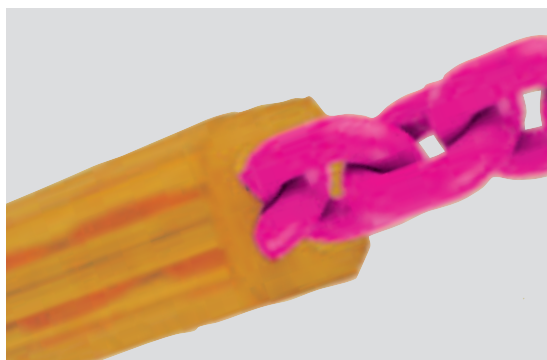

Edge protecting device RSK

Flexible in all directions. Manually movable along the chain. Even load distribution due to a diagonal transversal crucifix. Max. 2 m can be supplied. Available in 1 m and 2 m lengths

Chain size	Type	A	B	L_{max} .	Ref. No.
6	RSK – 6	27	27	2000	56 033
8	RSK – 8	33	33	2000	56 037
10	RSK – 10	38	38	2000	55 810
13	RSK – 13	50	50	2000	56 038

*further sizes upon request.

The suitable range of modern and safe Lifting Points – for bolting

Thread sizes M 6- M 150 Imperial (UNC,...) and special lengths on request		PP-S (Vario) PowerPoint-Star		PP-B (Vario) PowerPoint-B		PP-VIP (Vario) PowerPoint-VIP		VLBG Load Ring (Vario)															
Number of legs Load direction		Thread size	PP-S 0.63 t	PP-S 1.5 t	PP-S 2.5 t	PP-S 4 t	PP-S 5 t	PP-S 8 t	VLBG 0.3 t	VLBG 0.63 t	VLBG 1 t	VLBG 1.5 t	VLBG 2.5 t	VLBG 4 t	VLBG 4 t	VLBG 5 t	VLBG 7 t Sond.	VLBG 8 t	VLBG 10 t	VLBG 15 t	VLBG 20 t	LBG(3) M16 RS 1t	LBG(3) M20 RS 2t
		Type	M 12	M 16	M 20	M 24	M 30	M 36	M 8	M 10	M 12	M 16	M 20	M 24	M 27	M 30	M 36	M 36	M 42	M 42	M 48	M 16	M 20
	1 0°		0.6	1.5	2.5	4	6.7	10	0.3	0.6	1	1.5	2.5	4	4	5	7	8	10	15	20	1	2
	2 0°		1.2	3	5	8	13.4	20	0.6	1.2	2	3	5	8	8	10	14	16	20	30	40	2	4
	1 90°		0.6	1.5	2.5	4	5	8	0.3	0.6	1	1.5	2.5	4	4	5	7	8	10	15	20	1	2
	2 90°		1.2	3	5	8	10	16	0.6	1.2	2	3	5	8	8	10	14	16	20	30	40	2	4
	2 0-45°		0.8	2.1	3.5	5.6	7.1	11.2	0.4	0.8	1.4	2.1	3.5	5.6	5.6	7	9.8	11.2	14	21	28	1.4	2.8
	2 45-60°		0.6	1.5	2.5	4	5	8	0.3	0.6	1	1.5	2.5	4	4	5	7	8	10	15	20	1	2
	2 unsymmetrical		0.6	1.5	2.5	4	5	8	0.3	0.6	1	1.5	2.5	4	4	5	7	8	10	15	20	1	2
	3+4 0-45°		1.3	3.2	5.3	8.4	10.5	16.8	0.6	1.3	2.1	3.1	5.2	8.4	8.4	10.5	14.7	16.8	21	31.5	42	2.1	4.2
	3+4 45-60°		0.9	2.2	3.8	6	7.5	12	0.4	0.9	1.5	2.2	3.7	6	6	7.5	10.4	12	15	22.5	30	1.5	3
	3+4 unsymmetrical		0.6	1.5	2.5	4	5	8	0.3	0.6	1	1.5	2.5	4	4	5	7	8	10	15	20	1	2
		Thread size	M 12	M 16	M 20	M 24	M 30	M 36	M 8	M 10	M 12	M 16	M 20	M 24	M 27	M 30	M 36	M 36	M 42	M 42	M 48	M 16	M 20

Stain-
less

Maximum transport weight "G" in [tonnes] with different lifting methods

- All parts are either 100 % crack detected or proof loaded accord. to EN 1677.
- All original bolts from RUD are 100 % crack detected.
- Safety factor 4:1 in any direction.
- The types VRS, VRM, INOX-STAR and VLBG have to be adjusted to the load direction.
- Low installation height, high dynamic and static strength.
- RUD features such as clamping spring (VLBS) for noise reduction and distance lugs for a perfect root pass weld increase the ease of use.



The suitable range of modern and safe Lifting Points – for bolting

VWBG-V Load Ring (Vario)											VWBG Load Ring																		
VWBG-V 0.3 t	VWBG-V 0.45 t	VWBG-V 0.6 t	VWBG-V 1.0 t	VWBG-V 1.3 t	VWBG-V 1.8 t	VWBG-V 2 t	VWBG-V 2 t	VWBG-V 3.5 t	VWBG-V 3.5 t	VWBG-V 5 t	VWBG 6 (7.5)	VWBG 8 (10)	VWBG 8 (10)	VWBG 12 (13)	VWBG 12 (13)	VWBG 12 (15)	VWBG 13 (16)	VWBG 13 (16)	VWBG 14 (20)	VWBG 16 (22)	VWBG 16 (22)	VWBG 16 (25)	VWBG 16 (25)	VWBG 31.5 (40)	VWBG 31.5 (40)	VWBG 35 (48)	VWBG 35 (48)	VWBG 40 (50)	VWBG 40 (50)
M 8	M 10	M 12	M 14	M 16	M 18	M 20	M 22	M 24	M 27	M 30	M 33	M 36	M 36-39	M 42	M 42-45	M 45	M 48	M 48-52	M 52	M 56	M 56-62	M 64	M 64-76	M 72	M 72-76	M 80	M 80-85	M 90	M 90-150
0.6	0.9	1.2	2	2.6	3.6	4	4	7	7	10	15	15	15	17	17	18	18	18	25	28	28	28	28	50	50	50	50	50	50
1.2	1.8	2.4	4	5.2	7.2	8	8	14	14	20	30	30	30	34	34	36	36	36	50	56	56	56	56	100	100	100	100	100	100
0.3 (0.4)	0.45 (0.6)	0.6 (0.7)	1 (1.25)	1.3 (1.5)	1.8 (2)	2 (2.5)	2 (2.5)	3.5 (4)	3.5 (4)	5 (6)	6 (7.5)	8 (10)	8 (10)	12 (13)	12 (13)	12 (15)	13 (16)	13 (16)	14 (20)	16 (22)	16 (22)	16 (25)	16 (25)	31.5 (40)	31.5 (40)	35 (48)	35 (48)	40 (50)	40 (50)
0.6 (0.8)	0.9 (1.2)	1.2 (1.5)	2 (2.5)	2.6 (3)	3.6 (4)	4 (5)	4 (5)	7 (8)	7 (8)	10 (12)	12 (15)	16 (20)	16 (20)	24 (26)	24 (26)	24 (30)	26 (32)	26 (32)	28 (40)	32 (44)	32 (44)	32 (50)	32 (50)	63 (80)	63 (80)	70 (96)	70 (96)	80 (100)	80 (100)
0.4 (0.56)	0.6 (0.84)	0.8 (1.05)	1.4 (1.75)	1.8 (2.1)	2.5 (2.8)	2.8 (3.5)	2.8 (3.5)	4.9 (5.6)	4.9 (5.6)	7 (8.4)	8.4 (10.5)	11.2 (14)	11.2 (14)	16.8 (18.2)	16.8 (18.2)	16.8 (21)	18.2 (22.4)	18.2 (22.4)	19.6 (28)	22.4 (30.8)	22.4 (30.8)	22.4 (35)	22.4 (35)	44.1 (56)	44.1 (56)	49 (67.2)	49 (67.2)	56 (70)	56 (70)
0.3 (0.4)	0.45 (0.6)	0.6 (0.7)	1 (1.25)	1.3 (1.5)	1.8 (2)	2 (2.5)	2 (2.5)	3.5 (4)	3.5 (4)	5 (6)	6 (7.5)	8 (10)	8 (10)	12 (13)	12 (13)	12 (15)	13 (16)	13 (16)	14 (20)	16 (22)	16 (22)	16 (25)	16 (25)	31.5 (40)	31.5 (40)	35 (48)	35 (48)	40 (50)	40 (50)
0.3 (0.4)	0.4 (0.6)	0.6 (0.7)	1 (1.25)	1.3 (1.5)	1.8 (2)	2 (2.5)	2 (2.5)	3.5 (4)	3.5 (4)	5 (6)	6 (7.5)	8 (10)	8 (10)	12 (13)	12 (13)	12 (15)	13 (16)	13 (16)	14 (20)	16 (22)	16 (22)	16 (25)	16 (25)	31.5 (40)	31.5 (40)	35 (48)	35 (48)	40 (50)	40 (50)
0.6 (0.84)	0.9 (1.26)	1.2 (1.58)	2.1 (2.62)	2.7 (3.15)	3.7 (4.2)	4.2 (5.25)	4.2 (5.25)	7.3 (8.4)	7.3 (8.4)	10.5 (12.6)	12.6 (15.7)	16.8 (21)	16.8 (21)	25.2 (27.3)	25.2 (27.3)	25.2 (31.5)	27.3 (33.6)	27.3 (33.6)	29.4 (42)	33.6 (46.2)	33.6 (46.2)	33.6 (52.5)	33.6 (52.5)	66.15 (84)	66.15 (84)	73.5 (100)	73.5 (100)	84 (105)	84 (105)
0.4 (0.6)	0.6 (0.9)	0.9 (1.12)	1.5 (1.87)	1.9 (2.25)	2.7 (3)	3 (3.75)	3 (3.75)	5.2 (6)	5.2 (6)	7.5 (9)	9 (11.2)	12 (15)	12 (15)	18 (19.5)	18 (19.5)	18 (22.5)	19.5 (24)	19.5 (24)	21 (30)	24 (33)	24 (33)	24 (37.5)	24 (37.5)	47.25 (60)	47.25 (60)	52.5 (72)	52.5 (72)	60 (75)	60 (75)
0.3 (0.4)	0.4 (0.6)	0.6 (0.7)	1 (1.25)	1.3 (1.5)	1.8 (2)	2 (2.5)	2 (2.5)	3.5 (4)	3.5 (4)	5 (6)	6 (7.5)	8 (10)	8 (10)	12 (13)	12 (13)	12 (15)	13 (16)	13 (16)	14 (20)	16 (22)	16 (22)	16 (25)	16 (25)	31.5 (40)	31.5 (40)	35 (48)	35 (48)	40 (50)	40 (50)
M 8	M 10	M 12	M 14	M 16	M 18	M 20	M 22	M 24	M 27	M 30	M 33	M 36	M 36-39	M 42	M 42-45	M 45	M 48	M 48-52	M 52	M 56	M 56-60	M 64	M 64-76	M 72	M 72-76	M 80	M 80-85	M 90	M 90-150

Maximum transport weight "G" in [tonnes] with different lifting methods

Subject to technical modifications!

- RUD Lifting Point CD-ROM makes it easy to select the right Lifting Point.
- RUD Lifting Points conform fully dynamic applications of 20000 load cycles, with 50 % overload.
- In case of higher dynamic application please ask manufacturer.



The suitable range of modern and safe Lifting Points – for bolting

Thread sizes M 6- M 150 Imperial (UNC,...) and special lengths on request		Starpoint VRS (Vario) eyebolt		Starpoint VRM eyenut		INOX-STAR		RS & RM High-tensile eyebolt/eyenut		VRBG Load Ring																																					
Number of legs	Load direction	Type		Type		Type		Type		Type																																					
		Thread size	Thread size	Thread size	Thread size	Thread size	Thread size	Thread size	Thread size	Thread size	Thread size																																				
		M 6	M 8	M 10	M 12	M 16	M 20	M 24	M 30	M 36	M 42	M 48	2x M 16	4x M 20	4x M 30	6x M 30	8x M 36	6x M 48	10x M 48																												
	1 0°	0.5	1	1	2	4	6	8	12	16	24	32	1.2	2.4	3.6	5.2	-	0.4	0.8	1	1.6	3	4	6	8	12	16	24	32	3	10	16	31.5	50	85	100	200										
	2 0°	1	2	2	4	8	12	16	24	32	48	64	2.4	4.8	7.2	10.4	-	0.8	1.6	2	3.2	6	8	12	16	24	32	48	64	6	20	32	63	100	170	200	400										
	1 90°	0.1	0.3	0.4	0.7	1.5	2.3	3.2	4.5	7	9	12	0.5	1	2	2.5	-	<p>We recommend either »VRS-Starpoint« which can be adjusted to the direction of pull!</p>										3	10	16	31.5	50	85	100	200												
	2 90°	0.2	0.6	0.8	1.5	3	4.6	6.4	9	14	18	24	1	2	4	5	-											6	20	32	63	100	170	200	400												
	2 0-45°	0.1	0.4	0.56	1	2.1	3.2	4.5	6.3	9.8	12.6	16.8	0.7	1.4	2.8	3.5	-											4.2	14	22.4	45	70	119	140	280												
	2 45-60°	0.1	0.3	0.4	0.7	1.5	2.3	3.2	4.5	7	9	12	0.5	1	2	2.5	-											3	10	16	31.5	50	85	100	200												
	2 unsymmetrical	0.1	0.3	0.4	0.7	1.5	2.3	3.2	4.5	7	9	12	0.5	1.0	2.0	2.5	-											3	10	16	31.5	50	85	100	200												
	3+4 0-45°	0.2	1.0	1.63	0.8	1.5	3.1	4.8	6.7	9.4	14.7	18.9	25	1	2.1	4.2	5.3											-	6.3	21	33.6	67	105	178	210	420											
	3+4 45-60°	0.15	0.45	0.6	1.1	2.2	3.4	4.8	6.7	10.5	13.5	18	0.7	1.5	3	3.7	-											4.5	15	24	47.5	75	127	150	300												
	3+4 unsymmetrical	0.1	0.3	0.4	0.7	1.5	2.3	3.2	4.5	7	9	12	0.5	1	2	2.5	-											3	10	16	31.5	50	85	100	200												
		M 6	M 8	M 10	M 12	M 16	M 20	M 24	M 30	M 36	M 42	M 48	M 12	M 16	M 20	M 24	M 30											M 6	M 8	M 10	M 12	M 14	M 16	M 20	M 24	M 30	M 36	M 42	M 48	2x M 16	4x M 20	4x M 30	6x M 30	8x M 36	6x M 48	6x M 48	10x M 48

Maximum transport weight "G" in "tonnes" with different lifting methods

* The WLL values of the VRM are only valid with threaded bolts of quality 10.9.



The suitable product line of modern and safe lifting – and lashing points – weldable

	 all variations	 Stainless																														
		Number of legs		Load direction		Load direction		Load direction		Load direction		Load direction		Load direction		Load direction		Load direction		Load direction												
		WPP / WPPH 0.63 t	WPP / WPPH 1.5 t	WPP / WPPH 2.5 t	WPP / WPPH 4 t	WPP / WPPH 5 t	WPP / WPPH 8 t	VLBS 1.5 t	VLBS 2.5 t	VLBS 4 t	VLBS 6.7 t	VLBS 10 t	VLBS 16 t	LBS(1) RS 0.5 t	LBS(3) RS 1 t	LBS(5) RS 2 t	VRBS-FIX 4 t	VRBS-FIX 6.7 t	VRBS-FIX 10 t	VRBS-FIX 16 t	VRBS-FIX 31.5 t	VRBS 50 t	VRBK-FIX 4 t	VRBK-FIX 6.7 t	VRBK-FIX 10 t	ABA 1.6 t	ABA 3.2 t	ABA 5 t	ABA 10 t	ABA 20 t	ABA 31.5 t	
	1	0°	0.6	1.5	2.5	4	6.7	10	1.5	2.5	4	6.7	10	16	0.5	1	2	4	6.7	10	16	31.5	50	4	6.7	10	1.6	3.2	5	10	20	31.5
	2	0°	1.2	3	5	8	13.4	20	3	5	8	13.4	20	32	1	2	4	8	13.4	20	32	63	100	8	13.4	20	3.2	6.4	10	20	40	63
	1	90°	0.6	1.5	2.5	4	5	8	1.5	2.5	4	6.7	10	16	0.5	1	2	4	6.7	10	16	31.5	50	4	6.7	10	1.6	3.2	5	10	20	31.5
	2	90°	1.2	3	5	8	10	16	3	5	8	13.4	20	32	1	2	4	8	13.4	20	32	63	100	8	13.4	20	3.2	6.4	10	20	40	63
	2	0-45°	0.8	2.1	3.5	5.6	7.1	11.2	2.1	3.5	5.6	9.38	14	22.4	0.7	1.4	2.8	5.6	9.38	14	22.4	45	70	5.6	9.38	14	2.2	4.5	7.1	14.1	28	45
	2	45-60°	0.6	1.5	2.5	4	5	8	1.5	2.5	4	6.7	10	16	0.5	1	2	4	6.7	10	16	31.5	50	4	6.7	10	1.6	3.2	5	10	20	31.5
	2	unsymmetrical	0.6	1.5	2.5	4	5	8	1.5	2.5	4	6.7	10	16	0.5	1	2	4	6.7	10	16	31.5	50	4	6.7	10	1.6	3.2	5	10	20	31.5
	3+4	0-45°	1.3	3.2	5.3	8.4	10.5	16.8	3.15	5.25	8.4	14.1	21	33.6	1.05	2.1	4.2	8.4	14.1	21	33.6	67	105	8.4	14.1	21	3.4	6.8	10.6	21.2	42	67
	3+4	45-60°	0.9	2.2	3.8	6	7.5	12	2.25	3.75	6	10.1	15	24	0.75	1.5	3	6	10.1	15	24	47.5	75	6	10.1	15	2.4	4.8	7.5	15	30	47.5
	3+4	unsymmetrical	0.6	1.5	2.5	4	5	8	1.5	2.5	4	6.7	10	16	0.5	1	2	4	6.7	10	16	31.5	50	4	6.7	10	1.6	3.2	5	10	20	31.5
Weld			Δ	Δ	HY	HY	HY	HY	HV	HV	HV	HV	HV	HV	HV	HV	HY	HY	HY	HY	HY	HY	HY	HY	HY	HY	Δ	Δ	Δ	Δ	Δ	Δ
			3.5	4.5	3+5	3+6	3+8	3+10	5+3	7+3	8+3	12+4	16+4	25+6	5+3	8+3	12+4	3	5	6	9	12	25+8	3+4	3+5	8+3	4	6	7	8	12	15

Maximum transport weight "G" in "tonnes" with different lifting methods

Subject to technical modifications!





RUD Lashing chain ICE-CURT with highest LC (lashing capacity)



The proven, technical advantages of the **VIP**-program have been retained and further improved. Tensioning, connecting and shortening element have been improved considerably in weight and functionality.

ICE – in ICE-Pink (traffic purple) powder coated – means significant weight saving for the user. The standard equivalent Grade 80 commercial lashing chains are on average 60 % heavier.

This improved ergonomic design, enables faster fitting and heightened safety.

It is possible to use one diameter thinner than Grade 80 <math>< 16 \text{ mm } \varnothing</math>.

Up to 60 % higher Lashing Capacity (LC) than Grade 80 – also up to -60°C even in Arctic applications.

All values (conditions) of EN 12195-3 are fulfilled and the essential requirements are easily exceeded. All for the health and safety of the user!

ICE-CURT

Ratchet tensioner version with an integrated fast shortener, which is assembled captive in the chain strand. As an alternative there is a clevis type available also.

Patented:

“Secured against release by a magnet blocking clutch which can be secured with a lock. Theft protection of lashing chain and transporting goods.”

Thread tube now in an open and innovative form – robust, light in weight and due to the trapezoid thread easy to clean, check and lubricate.

Made in Germany.

All pieces drop forged, quenched and tempered and 100 % crack inspected.

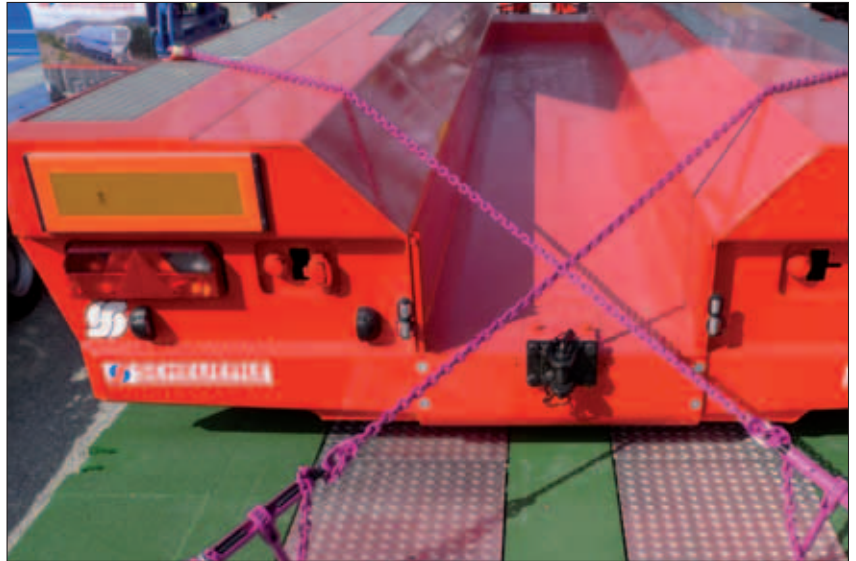

Subject to technical modifications!

ICE sets new benchmarks in lashing chain technology!



Up to 60 % more LC-Lashing Capacity than Grade 80 – with decisive handling benefits!

Which lashing chain for which load?

Diagonal lashing													
Lashing chain	LC [daN]	Max. load weight [t] (horizontal angle β : 20°-45°; 2 lashing chains per direction)											
		Vertical angle α : 0°-30°						Vertical angle α : 30°-60°					
		$\mu=0.1$	$\mu=0.2$	$\mu=0.3$	$\mu=0.4$	$\mu=0.5$	$\mu=0.6$	$\mu=0.1$	$\mu=0.2$	$\mu=0.3$	$\mu=0.4$	$\mu=0.5$	$\mu=0.6$
ICE-VSK 6	3600	6.2	8.4	10.4	13.0	17.4	26.2	4.5	6.3	9.0	12.8	19.2	32.0
ICE-VSK 8	6000	10.5	14.0	17.4	21.8	29.1	43.9	7.6	10.7	15.0	21.4	32.0	53.4
ICE-VSK 10	10000	17.5	23.4	29.0	36.4	48.6	73.1	12.8	17.9	25.0	35.6	53.4	89.0
ICE-VSK 13	16000	28.0	37.5	46.4	58.2	77.8	117.0	20.5	28.6	40.0	57.1	85.5	142.4
ICE-VSK 16	20000	43.7	58.6	72.6	91.0	121.6	182.8	32.0	44.7	62.5	89.1	133.6	222.5

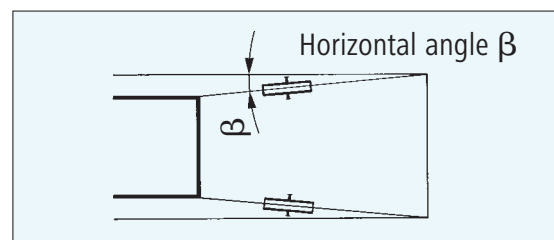
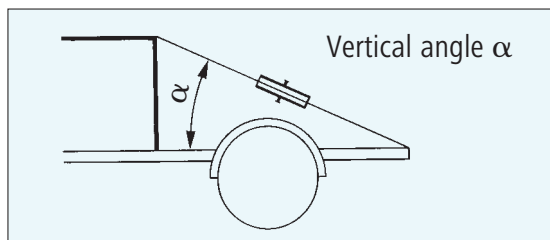

Frictional lashing													
RUD Lashing chain	STF [daN]	= required number of ICE lashing chains (number of lashing chains = factor from Table \times load weight [t])											
		Vertical angle α : 60°-90°						Vertical angle α : 30°-60°					
		$\mu=0.1$	$\mu=0.2$	$\mu=0.3$	$\mu=0.4$	$\mu=0.5$	$\mu=0.6$	$\mu=0.1$	$\mu=0.2$	$\mu=0.3$	$\mu=0.4$	$\mu=0.5$	$\mu=0.6$
ICE-VSK 6	1500	3.6 x	1.6 x	0.9 x	0.6 x	0.4 x	0.2 x	6.3 x	2.7 x	1.5 x	0.9 x	0.6 x	0.3 x
ICE-VSK 8	2800	2.0 x	0.9 x	0.5 x	0.3 x	0.2 x	0.1 x	3.4 x	1.5 x	0.8 x	0.5 x	0.3 x	0.2 x
ICE-VSK 10	2800	2.0 x	0.9 x	0.5 x	0.3 x	0.2 x	0.1 x	3.4 x	1.5 x	0.8 x	0.5 x	0.3 x	0.2 x
ICE-VSK 13	2800	2.0 x	0.9 x	0.5 x	0.3 x	0.2 x	0.1 x	3.4 x	1.5 x	0.8 x	0.5 x	0.3 x	0.2 x

Values of both tables refer to: stable load. road transport. no combination with other lashing or securing methods!

Slide-coefficient of friction μ			
Materials	dry	wet	greasy
Wood/wood	0.20-0.50	0.20-0.25	0.05-0.15
Metal/wood	0.20-0.50	0.20-0.25	0.02-0.10
Metal/metal	0.10-0.25	0.10-0.20	0.01-0.10

If there is a clear deviation from the indicated lashing angles, then it is necessary to add some safety measures (e.g. larger chain diameter, and/or – friction increasing elements).

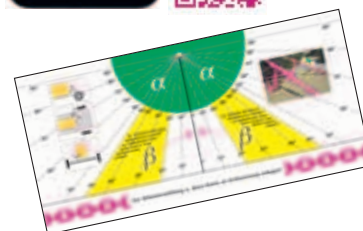

ICE-Lashig chains with ICE-CURT-Ratched spindle tensioner (vertical lashing and direct lashing)

Ratchet tensioner

Chain dia. [mm]	Type ratchet tensioner	Permissible LC	Obtainable pre-tension force	Hub [mm]	L-open [mm]	L-closed [mm]	Ref. No. Ratchet tensioner
6	ICE-CURT-6-GAKO	3600	1500	140	400	260	7903439
8	ICE-CURT-8-GAKO	6000	2800	170	520	350	7901125
10	ICE-CURT-10-GAKO	10000	2800	170	532	362	7901126
13	ICE-CURT-13-GAKO	16000	2800	300	830	530	7902624
16	ICE-CURT-16-GAKO	25000	—	350	962	612	7902625

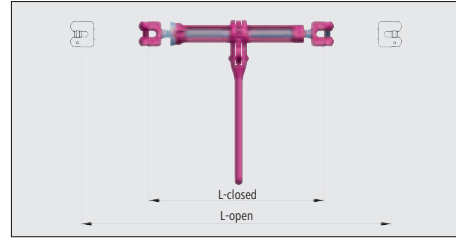

Chain dia. mm	Type lashing chain ICE-VSK-CURT-IVH	Permissible LC	Obtainable pre-tension force	L-min [mm]	Weight kgs (chain + ratchet tensioner)	Ref. No. Lashing chain
6	ICE-VSK-6-CURT-IVH	3600	1500	780	4.8 + 2.2	7903443
8	ICE-VSK-8-CURT-IVH	6000	2800	1040	8.0 + 5.2	7901129
10	ICE-VSK-10-CURT-IVH	10000	2800	1210	13.0 + 7.1	7901130
13	ICE-VSK-13-CURT-IVH	16000	2800	1600	21.9 + 13.6	7902626
16	ICE-VSK-16-CURT-IVH	25000	—	1910	34.5 + 24.3	7902627

Tensioner moveable within the chain strand

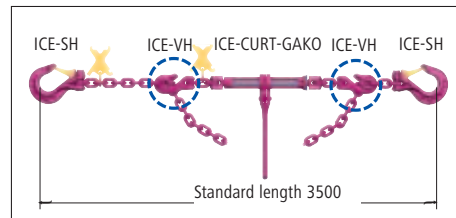

Chain dia. mm	Type lashing chain ICE-VSK-CURT-IMVK	Permissible LC	Obtainable pre-tension force	L-min [mm]	Weight kgs (chain + ratchet tensioner)	Ref. No. Lashing chain
6	ICE-VSK-6-CURT-IMVK	3600	1500	770	6.3	7904614
8	ICE-VSK-8-CURT-IMVK	6000	2800	1010	11.7	7904615
10	ICE-VSK-10-CURT-IMVK	10000	2800	1170	17.0	7904616
13	ICE-VSK-13-CURT-IMVK	16000	2800	1540	28.6	7904617
16	ICE-VSK-16-CURT-IMVK	25000	—	1840	46.0	7904618

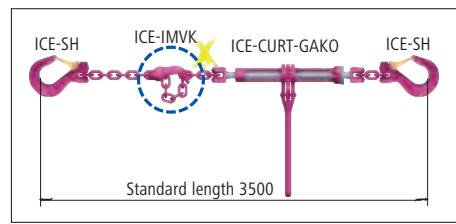

Chain dia. mm	Type lashing chain ICE-VSK-CURT-IVS	Permissible LC	Obtainable pre-tension force	L-min [mm]	Weight kgs (chain + ratchet tensioner)	Ref. No. Lashing chain
6	ICE-VSK-6-CURT-IVS	3600	1500	680	6.4	7904602
8	ICE-VSK-8-CURT-IVS	6000	2800	870	11.9	7904603
10	ICE-VSK-10-CURT-IVS	10000	2800	1000	17.7	7904604
13	ICE-VSK-13-CURT-IVS	16000	2800	1330	29.9	7904605
16	ICE-VSK-16-CURT-IVS	25000	—	1590	48.8	7904606

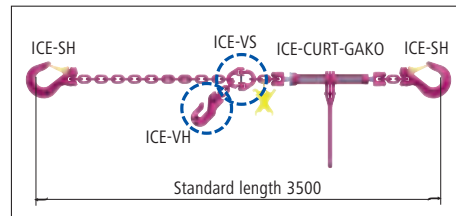

Ratchet tensioner

Chain dia. [mm]	Type ratchet tensioner	Permissible LC	Obtainable pre-tension force	Hub [mm]	L-open [mm]	L-closed [mm]	Ref. No. Ratchet tensioner
6	ICE-CURT-6-SL	3600	1500	140	470	330	7903441
8	ICE-CURT-8-SL	6000	2800	170	623	453	7999435
10	ICE-CURT-10-SL	10000	2800	170	671	501	7999436

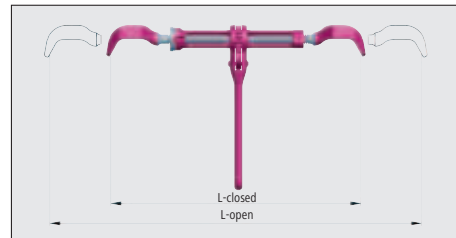

Chain dia. mm	Type lashing chain ICE-VSK-CURT-SL	Permissible LC	Obtainable pre-tension force	L-min [mm]	Weight kgs (chain + ratchet tensioner)	Ref. No. Lashing chain
6	ICE-VSK-6-CURT-SL	3600	1500	640	6.5	7903444
8	ICE-VSK-8-CURT-SL	6000	2800	817	12.6	7900026
10	ICE-VSK-10-CURT-SL	10000	2800	935	18.1	7900027

Captive tensioner moveable within the chain strand

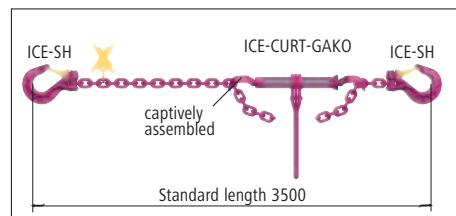

ICE-Lashing chains with ICE-CURT-K – Bar spindle tensioner (direct lashing only)

Tensioner with locking handle							
Chain dia. [mm]	Type Bar spindle tensioner	Permissible LC	Obtainable pre-tension force	Hub [mm]	L-open [mm]	L-closed [mm]	Ref. No. Tensioner with locking handle
6	ICE-CURT-K-6-GAKO	3600	direct lashing only	140	400	260	7904448
8	ICE-CURT-K-8-GAKO	6000	direct lashing only	170	520	350	7904449
10	ICE-CURT-K-10-GAKO	10000	direct lashing only	170	532	362	7904450
13	ICE-CURT-K-13-GAKO	16000	direct lashing only	300	830	530	7904451
16	ICE-CURT-K-16-GAKO	25000	direct lashing only	350	962	612	7904452

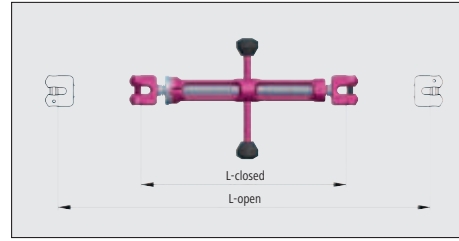

Chain dia. mm	Type lashing chain ICE-VSK-CURT-IVH	Permissible LC	Obtainable pre-tension force	L-min [mm]	Weight kgs (chain + Bar spindle tensioner)	Ref. No. Lashing chain
6	ICE-VSK-6-CURT-K-IVH	3600	direct lashing only	780	4.8 + 2.5	7904493
8	ICE-VSK-8-CURT-K-IVH	6000	direct lashing only	1040	8.0 + 4.5	7904494
10	ICE-VSK-10-CURT-K-IVH	10000	direct lashing only	1210	13.0 + 6.4	7904495
13	ICE-VSK-13-CURT-K-IVH	16000	direct lashing only	1600	21.9 + 12.6	7904496
16	ICE-VSK-16-CURT-K-IVH	25000	direct lashing only	1910	34.5 + 23.2	7904497

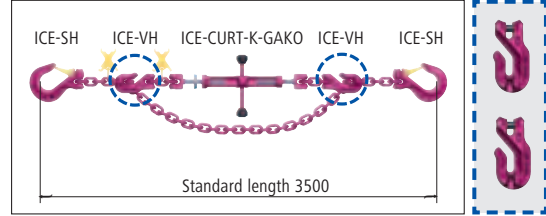

Tensioner moveable within the chain strand

Chain dia. mm	Type lashing chain ICE-VSK-CURT-IMVK	Permissible LC	Obtainable pre-tension force	L-min [mm]	Weight kgs (chain + Bar spindle tensioner)	Ref. No. Lashing chain
6	ICE-VSK-6-CURT-K-IMVK	3600	direct lashing only	770	6.6	7904608
8	ICE-VSK-8-CURT-K-IMVK	6000	direct lashing only	1010	11.0	7904610
10	ICE-VSK-10-CURT-K-IMVK	10000	direct lashing only	1170	16.3	7904611
13	ICE-VSK-13-CURT-K-IMVK	16000	direct lashing only	1540	27.6	7904612
16	ICE-VSK-16-CURT-K-IMVK	25000	direct lashing only	1840	44.9	7904613

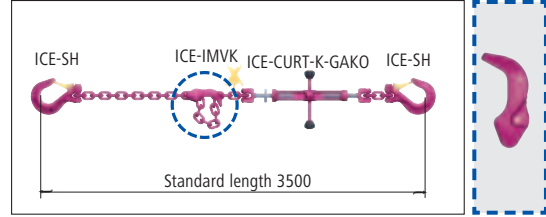

Chain dia. mm	Type lashing chain ICE-VSK-CURT-IVS	Permissible LC	Obtainable pre-tension force	L-min [mm]	Weight kgs (chain + Bar spindle tensioner)	Ref. No. Lashing chain
6	ICE-VSK-6-CURT-K-IVS	3600	direct lashing only	680	6.7	7904596
8	ICE-VSK-8-CURT-K-IVS	6000	direct lashing only	870	11.2	7904598
10	ICE-VSK-10-CURT-K-IVS	10000	direct lashing only	1000	17.0	7904599
13	ICE-VSK-13-CURT-K-IVS	16000	direct lashing only	1330	28.9	7904600
16	ICE-VSK-16-CURT-K-IVS	25000	direct lashing only	1590	47.7	7904601

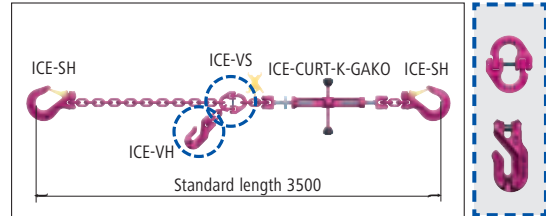

Tensioner with locking handle							
Chain dia. [mm]	Type tensioner with locking handle	Permissible LC	Obtainable pre-tension force	Hub [mm]	L-open [mm]	L-closed [mm]	Ref. No. (chain + Bar spindle tensioner)
6	ICE-CURT-K-6-SL	3600	direct lashing only	140	470	330	7904453
8	ICE-CURT-K-8-SL	6000	direct lashing only	170	623	453	7994454
10	ICE-CURT-K-10-SL	10000	direct lashing only	170	671	501	7994455

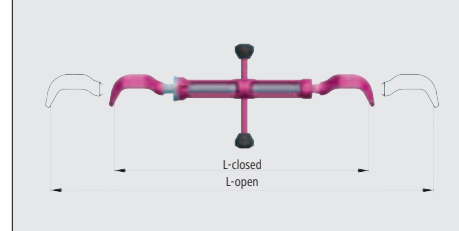

Chain dia. mm	Type lashing chain ICE-VSK-CURT-SL	Permissible LC	Obtainable pre-tension force	L-min [mm]	Weight kgs (chain + Bar spindle tensioner)	Ref. No. Lashing chain
6	ICE-VSK-6-CURT-K-SL	3600	direct lashing only	640	6.8	7904498
8	ICE-VSK-8-CURT-K-SL	6000	direct lashing only	817	11.7	7904499
10	ICE-VSK-10-CURT-K-SL	10000	direct lashing only	935	17.3	7904500

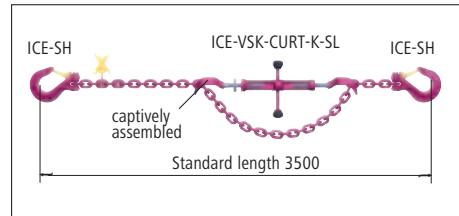

Captive tensioner moveable within the chain strand

Subject to technical modifications!





Chain Inspection Service
- prioritising security! -



RUD lifting and lashing means - Inspection service:
Inspection means safety and conservation of value! The RUD inspection service offers an on location complete safety service. We inspect the lifting and lashing means according to the below listed six point program. Our technicians are qualified specialists according to EN ISO 9712 and work with modern testing devices. Inspection certification according to BGR 500 and the new EC - law.



VIP-ID tag incl. Testing guide
*for VIP-lifting/
**lashing chains

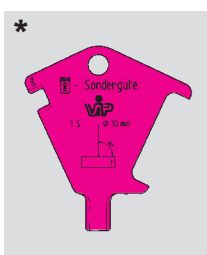

Chain	Type	Ref. No.
6	VKPL-6	71 00 639
8	VKPL-8	71 00 657
10	VKPL-10	71 00 662
13	VKPL-13	71 00 667
16	VKPL-16	71 00 672
20	VKPL-20	71 04 045
22	VKPL-22	71 01 832



Chain	Type	Ref. No.
6	VSK-KPL-6	7988623
8	VSK-KPL-8	7988624
10	VSK-KPL-10	7988625
13	VSK-KPL-13	7988626
16	VSK-KPL-16	7988627



Testing wear of nominal dia.



Testing for elongation caused by wear of nominal diameter.



Testing for pitch elongation caused by overload.

■ At regular intervals (maximum: one year) **chain assemblies** must be inspected by a competent person. Depending on the application circumstances, inspection might be necessary with in a time interval of less than one year. After a max. period of three years, chains must under go special inspection for the detection of cracks. After the occurrence of a special incident, which could affect the WLL, chains should also be inspected by a compe-

tent person. In the case of VIP chains and components, proof loading instead of magnetic crack detection is insufficient. After the magnetic crack detection, probable cracks will be visible despite the pink powder coating. Use the crack detection fluid "Ferroflux".



Regular Maintenance and Testing

■ **Visual examination:** This reveals any exterior defects for example deformed or twisted chain links or chain links with notches. Examine the components as to the correct fitting, completeness and efficiency of the safety devices.

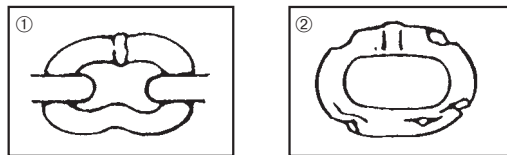

■ **Examination of wear and elongation:**

1. Examine wear of diameter.
2. Examine the plastic elongation caused by overload, more than 5 % based on the pitch 3d. $D_m = d_1/2 + d_2/2 \geq 0.9 d$
3. Determine the pitch elongation caused by wear of the diameter. This can be easily carried out using the VIP testing gauge (refer to page 6 and 48).

$$D_m = \frac{d_1 + d_2}{2} \geq 0.9 d$$

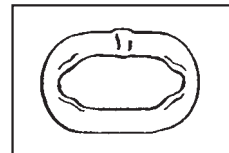
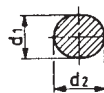

■ **Accessories:** When the opening of the hook is deformed by more than 10 % or worn out by more than 5 %, it must be replaced. The same applies if the hook has got deep notches. For wear marks dimensions F refer to VCGH on pages 18 and 19. The same applies as for the lateral bending of the hook.

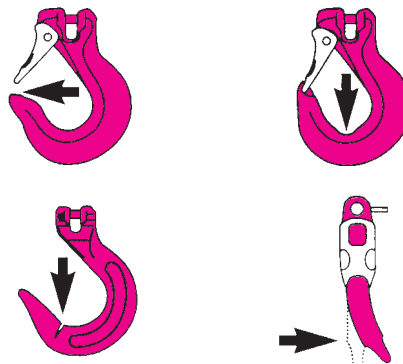

Permissible max. wear of the VG – bolt diameter $\leq 10 \%$.

When replacing components, always use new connecting bolts and tensioning sleeves.

■ **Documentation in a chain register:**

The entries in the chain register card give us information about the continuous inspection measures under taken by the user in the course of using the lifting and lashing chains. For the user, this can additionally be used as evidence to be presented to the respective authorities to prove compliance with accident prevention measures as required by the EC-machinery directives.



The new RUD-ID-System® will support your product administration and documentation (see pages 8 and 9).

■ Only RUD original spare parts must be used!

VIP-chains and components must be kept away from aggressive chemicals and acids. Surface treatment can only be undertaken by the manu-

facturer. Pay attention to the influence of temperatures (refer to the table on pages 4 and 7).

Please strictly adhere to the following regulations and specifications: BetrSichV – BGR 500, EN 818, EN 1677 and the RUD user instructions.

We are not liable for damages incurred as a result of ignoring the above regulations and specifications.



CD-USER- INFORMATION on CD-ROM or www.rud.com



Always
"up to
date"!



Interactive programme with ICE- and VIP-Lashing Calculation Program and Lashing Protocol!

Using the questionnaire the most important data is entered, for example: working load, number of lifting points (or distance between lifting points), angle, shock load impact, sharp corners, influence of temperature etc.

Automatically the correct ICE and VIP Chain Sling or lifting point will be determined within seconds. You can print out: Drawings, part lists, lashing protocols, calculation of the selected components.

SELECTION	USE	INSPECTION/TEST	MAINTAINING/REPAIR	DOCUMENTATION
1	2	3	4	5

Short user Information

Reference No.: 7982411

USER INSTRUCTION

- Benutzung nur durch Beauftragte, die in die Unterweisungsinstruktion und die Unfallverhütungsvorschrift VBG 9a unterwiesen sind und die Abweichungen von normalen Einsatzbedingungen erfordern (Schlupf und reduzierungen v. B. bei Unsymmetrie, beim Anschlag im Schräglage und beim Einsatz außerhalb des Temperaturbereiches von -40° bis 200° C).
- Einsatz unter chemischen Einflüssen wie z. B. in Säuren, Laugen und deren Dämpfe verboten.
- Anschlag nur an geeigneter Last-Anschlagstelle. Nicht an Umschnürung der Last fassen.
- Überprüfung und Instandsetzung nur durch Sachkundige.
- Prüfintervalle beachten.
- Vor Inbetriebnahme der Anschlagkette Betriebsanleitung/Benutzerinformation lesen und beim Gebrauch beachten.
- Auf Vollständigkeit und Wirksamkeit der Sicherheitsvorrichtungen ist zu achten.
- VIP-Ketten dürfen nur mit VIP-Zubehörteilen verwendet werden.

RUD-Kettenfabrik, Rieger & Dietz GmbH u. Co., D-73428 Aalen

According to EC Machinery Directive 2006/42/EG - BetrSichV - BGR 500.



User Information for RUD Chain Sling

Reference No.: 7101649

Identification, inspection and documentation made easy!



...with RFID!

see pages 8/9



RUD-Quality in PINK!
Grade 80, Grade 100 (VIP) and Grade 120 (ICE)
WLL in metric tons of sling chains
According to inclination angle at symmetric loading

Methods of sling

WLL	Grade 80	Grade 100 (VIP)	Grade 120 (ICE)
100	100	100	100
150	150	150	150
200	200	200	200
250	250	250	250
300	300	300	300
350	350	350	350
400	400	400	400
450	450	450	450
500	500	500	500
550	550	550	550
600	600	600	600
650	650	650	650
700	700	700	700
750	750	750	750
800	800	800	800
850	850	850	850
900	900	900	900
950	950	950	950
1000	1000	1000	1000

Reference No.: 7102334

VIP WLL Poster

Size 420 x 625 mm
Special Grade and Grade 80.

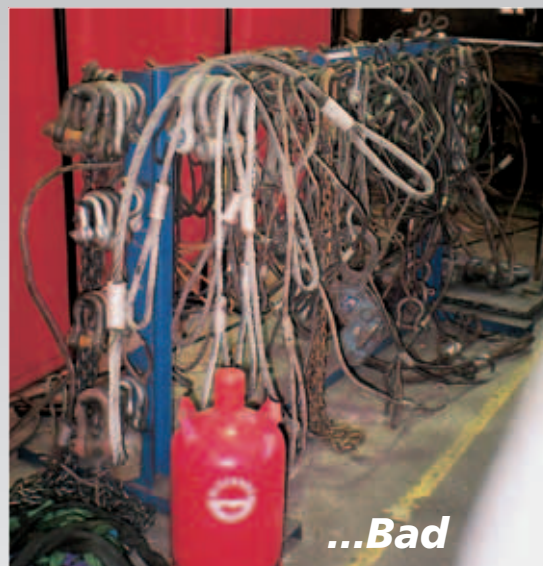

Storage of lifting and lashing system components.

Hang the components appropriately in a frame.

RUD-Quality in PIN

Grade 80, Grade 100 (VIP) and Grade 120 (ICE) »in metric tons« of sling
According to inclination angle at symmetrical load



RUD quality grades

80	100	120
100 %	133 %	160 %
WLL		

Grade 80
Grade 100 (VIP)
Grade 120 (ICE)

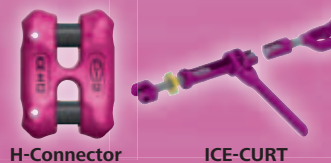

Methods of sling

RUD ID System		1-leg			2-leg		3-4 leg		
		inclination angle: β		load factor		Diam. of chains		Quality grade	
		0	0-45°	> 45-60°	0-45°	> 45-60°			
		1.0	1.4	1.0	2.1	1.5			
		Ø 4		VIP		ICE			
		0.63	0.88	0.63	1.32	0.95			
		0.80	1.12	0.80	1.70	1.18			
		Ø 6		Grade 80		VIP		ICE	
		1.12	1.6	1.12	2.36	1.7			
		1.5	2.1	1.5	3.15	2.25			
		1.8	2.5	1.8	3.75	2.7			
		Ø 8		Grade 80		VIP		ICE	
		2.0	2.8	2.0	4.25	3.0			
		2.5	3.5	2.5	5.25	3.75			
		3.0	4.25	3.0	6.3	4.5			
		Ø 10		Grade 80		VIP		ICE	
		3.15	4.25	3.15	6.7	4.75			
		4.0	5.6	4.0	8.4	6.0			
		5.0	7.0	5.0	10.5	7.5			
		Ø 13		Grade 80		VIP		ICE	
		5.3	7.5	5.3	11.2	8.0			
		6.7	9.5	6.7	14.0	10.0			
		8.0	11.2	8.0	17.0	11.8			
		Ø 16		Grade 80		VIP		ICE	
		8.0	11.2	8.0	17.0	11.8			
		10.0	14.0	10.0	21.2	15.0			
		12.5	17.0	12.5	26.5	19.0			
		Ø 18		Grade 80		VIP		ICE	
		10.0	14.0	10.0	21.2	15.0			
		Ø 20		Grade 80		VIP		ICE	
		12.5	17.0	12.5	26.5	19.0			
		16.0	22.4	16.0	33.6	24.0			
		Ø 22		Grade 80		VIP		ICE	
		15.0	21.2	15.0	31.5	22.4			
		20.0	28.0	20.0	42.0	30.0			
		Ø 26		Grade 80		VIP		ICE	
		21.2	30.0	21.2	45.0	31.5			
		Ø 28		Grade 80		VIP		ICE	
		31.5	45.0	31.5	67.0*	47.5*			
		Ø 32		Grade 80		VIP		ICE	
		31.5	45.0	31.5	67.0	47.5			



Attention:
Acc. to BGR 500 section 2.8, the WLL for single fall becomes valid when unsymmetrical load occurs at a multiple strand sling.

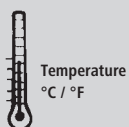

Subject to technical modifications! *Only 2 x 2-leg type available.

K!

Grade 120 (ICE) g chains metric loading



endless** Basket sling chain with choke hitch	Basket sling chain**				Choke hitch**		
	single		double		single	double	
	0-45°	> 45-60°	0-45°	> 45-60°	0	0-45°	> 45-60°
-	1.6	0.8	1.7	1.2	0.8	1.1	0.8
1.0	0.69	0.5	1.1	0.75	0.5	0.69	0.5
1.25	0.88	0.64	1.36	0.96	0.64	0.88	0.64
1.8	1.2	0.9	1.9	1.3	0.9	1.2	0.9
2.4	1.65	1.2	2.55	1.8	1.2	1.65	1.2
2.88	2.0	1.44	3.1	2.1	1.44	2.0	1.44
3.2	2.2	1.6	3.4	2.4	1.6	2.2	1.6
4.0	2.75	2.0	4.25	3.0	2.0	2.75	2.0
4.8	3.3	2.4	5.1	3.6	2.4	3.3	2.4
5.0	3.5	2.5	5.3	3.8	2.5	3.5	2.5
6.4	4.4	3.2	6.8	4.8	3.2	4.4	3.2
8.0	5.5	4.0	8.5	6.0	4.0	5.5	4.0
8.5	5.8	4.0	9.0	6.0	4.0	5.8	4.0
10.6	7.5	5.3	11.2	8.0	5.3	7.5	5.3
12.5	8.8	6.4	13.6	9.6	6.4	8.8	6.4
12.5	8.8	6.4	13.6	9.6	6.4	8.8	6.4
16.0	11.0	8.0	17.0	12.0	8.0	11.0	8.0
20.0	14.0	10.0	21.2	15.0	10.0	14.0	10.0
16.0	11.0	8.0	17.0	12.0	8.0	11.0	8.0
20.0	14.0	10.0	21.2	15.0	10.0	14.0	10.0
25.6	17.6	12.8	27.2	19.2	12.8	17.6	12.8
23.6	16.5	12.0	25.5	18.0	12.0	16.5	12.0
32.0	22.0	16.0	34.0	24.0	16.0	22.0	16.0
33.5	23.3	17.0	36.0	25.4	17.0	23.0	17.0
50.0	35.5	25.0	53.0*	37.5*	25.0	35.5	25.0
50.0	35.5	25.0	53.0	37.5	25.0	35.5	25.0
Grade 80	-40° up to +200° C (+40° up to +392° F)		higher 200° up to 300° C (higher 392° up to 572° F)		higher 300° up to 400° C (higher 572° up to 752° F)		
	100 %		90 %		75 %		
VIP 100	-40° up to +200° C (+40° up to +392° F)		higher 200° up to 300° C (higher 392° up to 572° F)		higher 300° up to 380° C (higher 572° up to 716° F)		
	100 %		90 %		60 %		
ICE 120	-60° up to +200° C (-76° up to +392° F)		higher 200° up to 250° C (higher 392° up to 482° F)		higher 250° up to 300° C (higher 482° up to 572° F)		
	100 %		90 %		60 %		

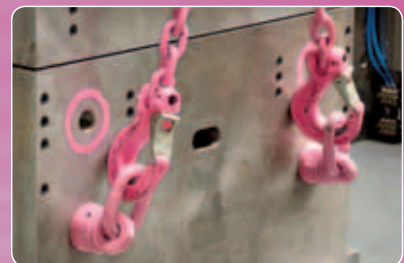

RUD Ketten
Rieger & Dietz GmbH u. Co. KG
Friedensinsel
73432 Aalen/Germany
Tel.: +49 7361 504-1316-1370-1224
Fax: +49 7361 504-1460
sling@rud.com · www.rud.com

**20 % reduction
for basket chains,
due to sharp edges,
is considered.



RUD[®]

Important information!

Optimal load securing...

...with **VIP** and **ICE-Lashing** means

Best load securing – a compulsory legal necessity!

ICE I20 

Edition 22



RUD[®]

RUD-LIFTING POWER
...EVERY LOAD UNDER CONTROL!

ICE I20 + VIP 100

MADE IN GERMANY

LIFTING POINTS 





Tradition in Dynamic Innovation

RUD Ketten
Rieger & Dietz GmbH u. Co. KG
Friedensinsel
73432 Aalen/Germany
Telefon +49 7361 504-1371
Telefax +49 7361 504-1460
sling@rud.com
www.rud.com

German engineering
from the heart
of Europe!

