

DRIVE TECHNOLOGY

PIVOTING · LIFTING · MOVING · TELESCOPING · ROTATING



POWERFUL IN EVERY ENVIRONMENT!

- ✓ Durable, reliable and safe
- ✓ Complete solutions for all requirements
- ✓ Competent on-site service





RUD Conveyor & Drive technology

High performance for all environments

Irrespective of whether one is interested in horizontal, curved or vertical drive concepts - RUD conveyor and drive systems provide a variety of system solutions with round steel chains for various applications in bucket elevators, power generation, onshore and offshore, underground mining and in the industrial and hoist chain sectors.

Numerous internationally acclaimed companies show confidence in RUD Drive technology:



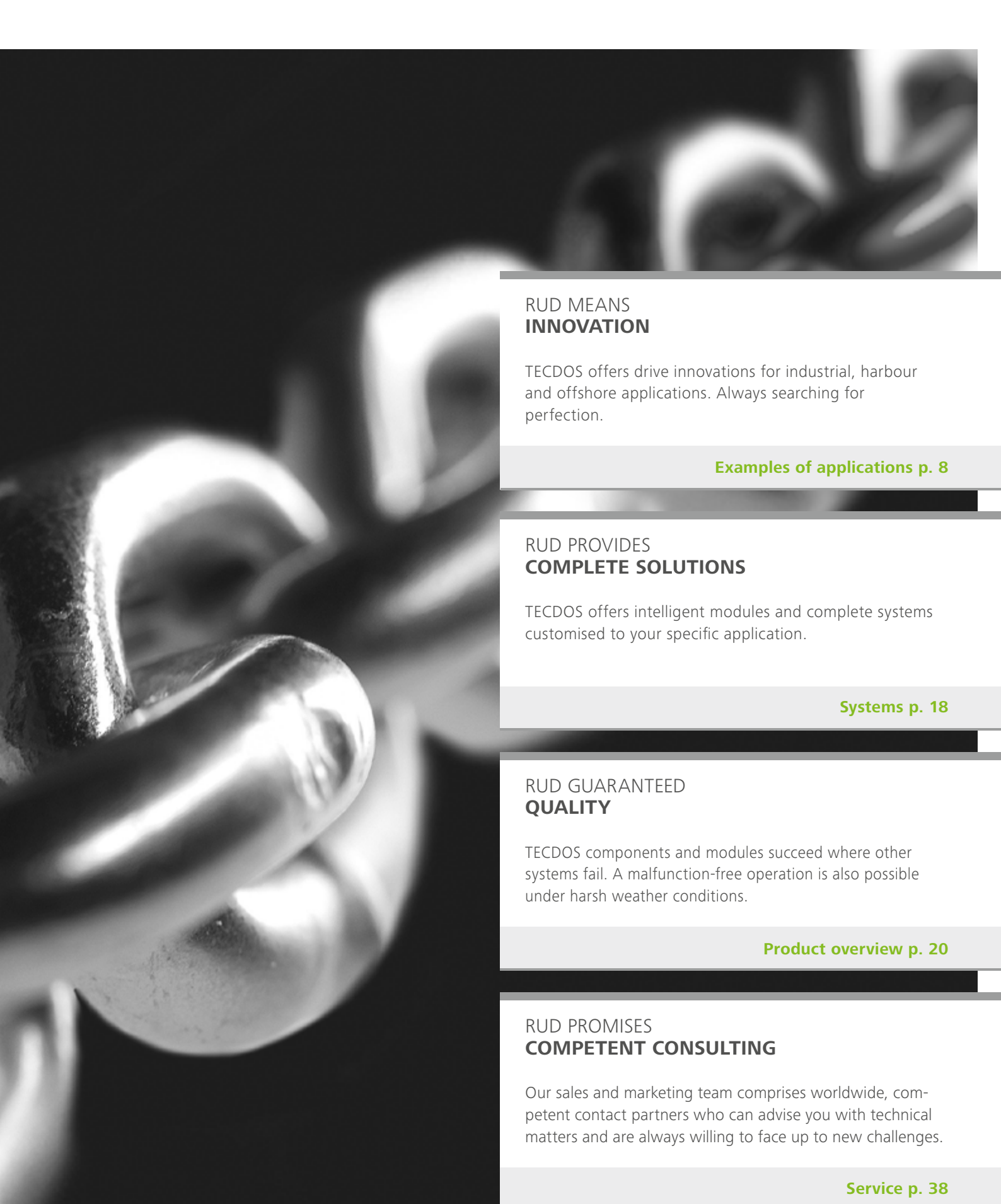

RUD MEANS **INNOVATION**

TECDOS offers drive innovations for industrial, harbour and offshore applications. Always searching for perfection.

Examples of applications p. 8

RUD PROVIDES **COMPLETE SOLUTIONS**

TECDOS offers intelligent modules and complete systems customised to your specific application.

Systems p. 18

RUD GUARANTEED **QUALITY**

TECDOS components and modules succeed where other systems fail. A malfunction-free operation is also possible under harsh weather conditions.

Product overview p. 20

RUD PROMISES **COMPETENT CONSULTING**

Our sales and marketing team comprises worldwide, competent contact partners who can advise you with technical matters and are always willing to face up to new challenges.

Service p. 38

Symbol Legend



ROUND LINK CHAIN



OMEGA DRIVE



ATTACHMENTS / GEARMOTOR



Pi / Gamma



CHAIN GUIDE



END FIXING



CHAIN WHEEL



SERVICE



TOOL MOVER

Index

01. TECDOS® Overview of markets

1.1 Maritime & Offshore	08
1.2 Machine Engineering & Plant Engineering.....	09

02. TECDOS® Drive solutions

2.1 Lifting	12
2.2 Telescoping	14
2.3 Process	14
2.4 Rotating	16

03. TECDOS® Systems

3.1 Product overview Individual componets.....	20
3.2 PI-/GAMMA Drive	22
3.3 OMEGA DRIVE	24
3.4 OMEGA DRIVE modular system	27
3.5 TOOL MOVER	28

04. TECDOS® Spare parts & components

4.1 TECDOS round link chain	32
4.2 TECDOS pocket wheels	34
4.3 TECDOS chain guide	35
4.4 RUD lift limiter.....	36
4.5 RUD connector	36
4.6 TECDOS end fixing.....	36
4.7 RUD foolproof high dynamic shackle.....	37
4.8 RUD PowerPoint fixing point.....	37
4.9 RUD cobra fork head hook.....	37

05. Service & Information

Technical charts product overview	38
Technical questionarie for Drive systems	47





Discover now RUD TECDOS chains drivers and components on traceparts. RUD product download simplifies design! [Click here](#) or search www.traceparts.com/en for TECDOS.

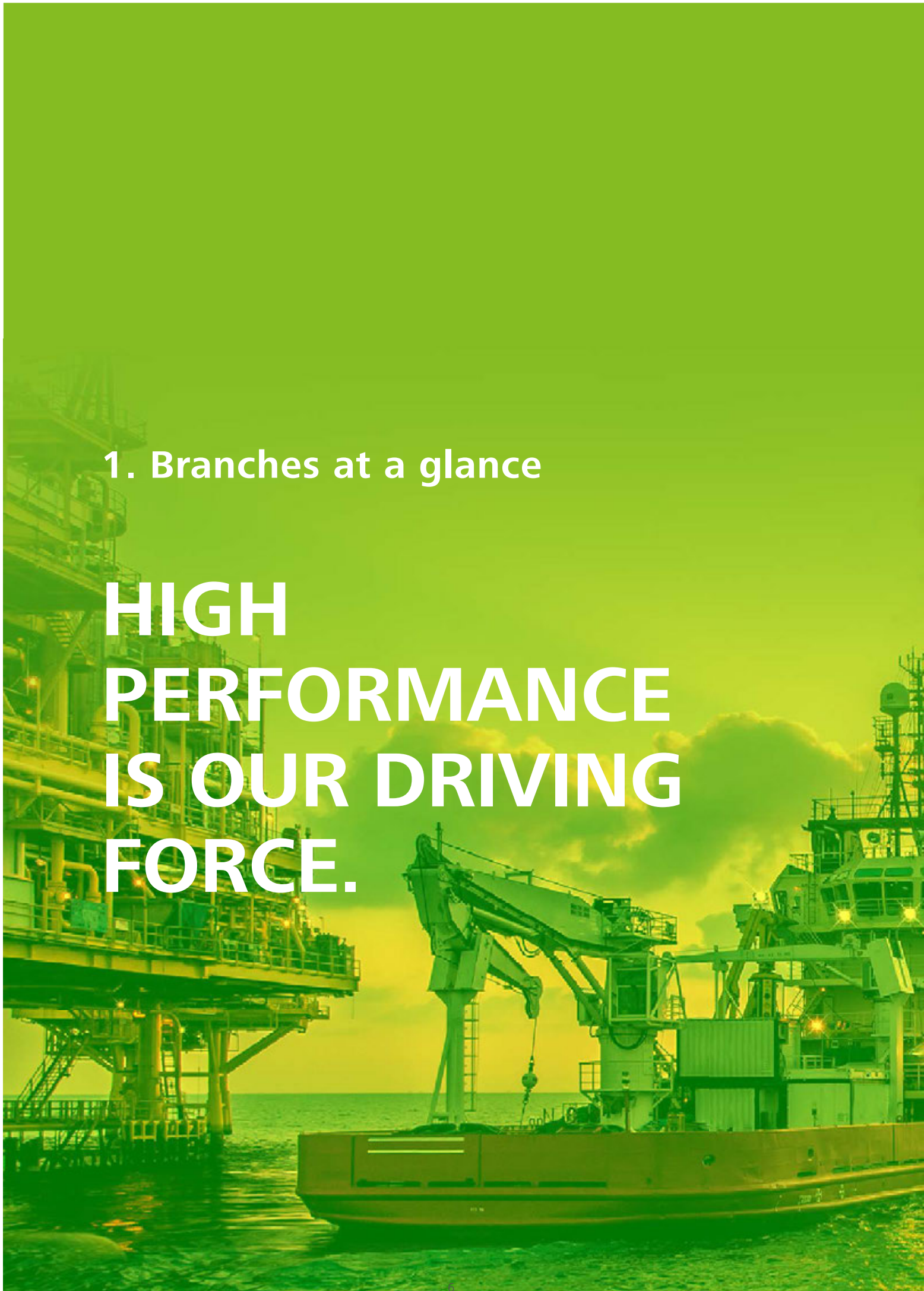

1. Branches at a glance

**HIGH
PERFORMANCE
IS OUR DRIVING
FORCE.**





PIVOTING LIFTING MOVING TELESCOPING ROTATING

Whatever direction you want to move something in, the combination of TECDOS components provides suitable solutions for the most diverse fields of industry.

1. TECDOS® Branches at a glance

1.1 Maritime & Offshore



Deck Equipment



Port- & Harbour-Equipment



Handling Solutions

1.2 Machine Engineering & Plant Engineering



Handling Solutions



Automotive



Mining & Toolhandling

2. Drive solutions

**ROBUST, EFFECTIVE,
SPACE-SAVING.**





MOVE ADJUST DRIVE

Innovative and high-performance drive systems
for linear and rotating movements.

2. TECDOS® drive solutions

2.1 Lifting



Sectional door drive units Moving doors with weights of several tonnes

Doors which weigh several tons e.g. in hangars or industrial halls must be reliably opened and closed, so neither people may be injured nor objects may be damaged. A combination of diverse technical drive components provides a trouble-free application.



RUD Solution

- TECDOS premium chain strands for lifting and lowering
- RUD lifting means and aids as linkage for counterweights
- TECDOS chain wheels: weather resistant, corrosion resistant and robust
- End user can combine roller chain with round link chain



Gangway Robust, variable and compact

Gangways and ship access systems must be adjustable in longitudinal and transverse directions as well as for the height for different models and sizes of vessels so that safe access for passengers and crew is ensured.

RUD Solution

- TECDOS medium chain
- Pi-drive
- End fixing
- Lift limiter





Wagon unloading equipment

Rapid and safe material unloading

A shunting transshipment port for bulk goods requires a facility with which railway wagons could be unloaded rapidly and safely. Loads of up to 100 tons could not should be lifted and tipped in this case.

RUD Solution

- TECDOS medium chain
- Pocketwheels



Lifting equipment for final vehicle assembly

Variable height for ergonomic working

Vehicles attached to load frames must be traversed variably in height to enable ergonomic working during final assembly. The load frames must not hereby swing in the horizontal axis and only limited installation space is available for the drive unit.

RUD Solution

- TECDOS premium chain, tensioned all round as crisscross
- 4-fold pocketwheel-drive shaft
- pocketwheel deflection wheels
- Chain guide
- End fixing



→ Scan the QR code and watch the video!

2. TECDOS® drive solutions

2.2 Telescoping



Ship Loader

Flexible ship loading

Mobile ship loaders with mobile booms are utilised for loading of bulk goods on cargo ships. This equipment enable the cargo to be evenly distributed in the freight hold.

RUD Solution

- TECDOS premium chain
- Pocketwheel in OMEGA arrangement
- Chain guide
- End fixing



→ Scan the QR code and watch the video!

2.3 Process



Rail Wagon Unloading System

Handle heavy object safely

The availability of the railway wagon unloading system should be increased.

RUD Solution

- TECDOS premium chain
- Pocketwheel in OMEGA arrangement
- End fixing





Spud Pole Skidding

Anchoring and positioning system for dredgers

Dredgers must be positioned safely and moved forward step by step in order to expand and dredge canals.

The 9 m long travel route is therefore executed at a speed of 5m/minute. The tensile forces on the chains normally amount to 90kN although they can increase up to 130kN.



RUD Solution

- TECDOS premium chain
- End fixing
- TECDOS OMEGA Drive



→ Scan the QR code and watch the video!



Skidding

Reliable solution for moving loads from one point to another

For bulk material handling on a dredger, a robust and easy-to-install solution was sought, which is particularly resistant to sand or gravel blocking.

RUD Solution

- OMEGA drive concept
- TECDOS premium chain
- End fixing



→ Scan the QR code and watch the video!

2. TECDOS® drive solutions

2.3 Process



Spooling

Equipment for cable winches and double drum winches

For a hydraulically driven double drum anchor towing winch with a cable pull of 500 tons, a winding device was needed.

RUD Solution

- TECDOS medium chain
- End fixing for round link chain
- Double strand pocketwheel



2.4 Rotating



Blade Turning Device

Transporting bulky, sensitive rotor blades

Assembling and erecting turbines requires handling equipment with which the long rotor blades [up to 80 Mtrs] can be secured, aligned horizontally and rotated around the longitudinal axis.

RUD Solution

- TECDOS medium chain
- Pocketwheels



→ Scan the QR code and watch the video!



Rotating & Turning Equipment

Rotating rotor blades

Rotor blades for wind turbines are laminated in half-shells during manufacturing. To ensure that the multiple layers of glass-fibre or carbon-fibre-reinforced plastic can be inserted with millimetre precision and without wrinkles, the half-shells must be rotated around the longitudinal axis during moulding.

RUD Solution

- TECDOS premium chain
- Pocketwheel in OMEGA arrangement
- End fixing



→ Scan the QR code and watch the video!



TOOL MOOVER Handling

Handle heavy tools safely

„Turning heavy tools safely“ - the RUD TOOL MOOVER was specially developed for the safe turning of heavy-duty tools and heavy-duty workpieces in your manufacture facility.

RUD Solution

- TECDOS premium chain
- TECDOS end fixing
- TECDOS Omega Drive
- Compatible accessories optional



→ Scan the QR code and watch the video!

Configure your TOOL MOOVER quickly and easily!

More information:

www.rud.com/en/products/conveyor-drive-systems/

3. Systems

**SAFE THROUGH
DAILY LIFE.**





HANDY RISKFREE FLEXIBLE













Our systems and components guarantee sustainable solutions, even under difficult conditions. TECDOS systems are user friendly and can be combined flexibly.

3. TECDOS® Systems

3.1 Product overview | individual components

For the construction of a complete TECDOS drive solution, based on the TECDOS high performance round link chain, we can provide the most diverse components and systems for every requirement. All TECDOS round steel chains are stamped and this ensures traceable evidence to the melt over standard 3.1 certificates.

TECDOS® Individual componets

	<p>TECDOS® round link chain medium (quenched and tempered)</p> 	<p>premium (case hardened)</p> 	<p>→ p. 32</p>
	<p>pocket wheel</p> 	<p>chain guide</p> 	<p>→ p. 34 p. 35</p>
	<p>Chain end fixing</p> 	<p>PowerPoint fixing point</p> 	<p>Cobra fork head hook</p> 
<p>Foolproof high dynamic shackle</p> 	<p>Lift limiter</p> 	<p>Chain connectors</p> 	<p>→ p. 36</p>

traceparts  Discover now **RUD TECDOS chains drivers and components** on traceparts. RUD product-download simplifies design! [Click here](http://www.traceparts.com/en) or search www.traceparts.com/en for **TECDOS**.
Product Content *Everywhere*

- 
ROUND LINK CHAIN
- 
CHAIN GUIDE
- 
END FIXING
- 
CHAIN WHEEL
- 
OMEGA DRIVE
- 
ATTACHEMENTS /
GEARMOTOR
- 
PI/GAMMA DRIVE

 **GAMMA drive**
Complete systems incl. pocket wheel for a chain redirection of 90°.

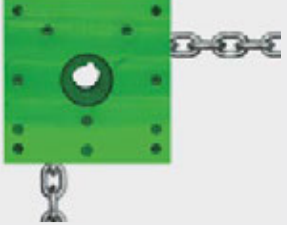

PI-drive
Complete systems incl. pocket wheel for a chain redirection from 90° to 180°.

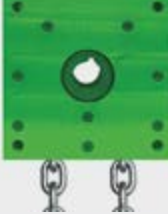

→ p. 22

 **OMEGA DRIVE**
Drive solution with SEW electric motor. Adapter flange, TECDOS high performance chain and OMEGA DRIVE



→ p. 24

 **Attachements & Motors**
Drive unit / motor and shaft

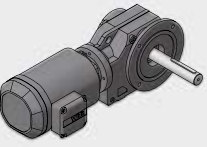

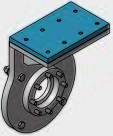

Mounting rail and adapter flange



Complete systems are available with motors from leading manufacturers.

→ p. 27

 **TECDOS complete system | TOOL MOVER**
For the safe handling and rotation of heavy and precision injection moulding tools and other objects.



→ p. 28

3. TECDOS® systems

3.2 PI / GAMMA drive | Pocket wheel blocks

PI pocketwheel blocks enable vertical and horizontal drive with 180° chain wrapping, while the GAMMA pocketwheel block is utilised for drives with 90° redirection.

PI wrap angle 180°

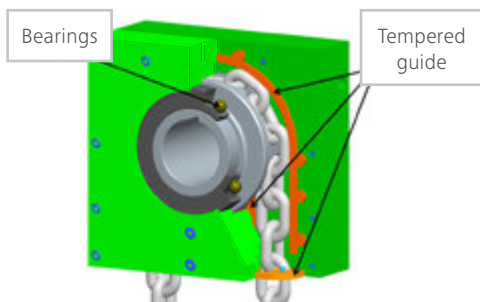

GAMMA wrap angle 90°

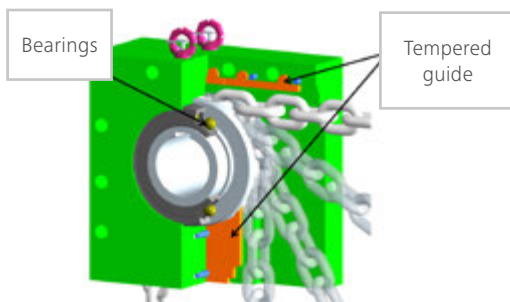

Attachements PI / GAMMA:

Along with TECDOS end fixings, many attachment solutions are available from the VIP lifting means* program.

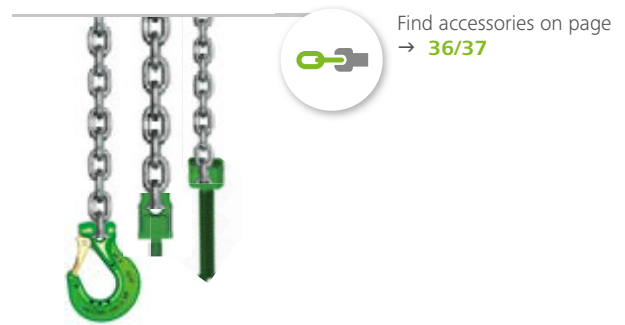

*The VIP standard bolt must be replaced by a TECDOS special bolt when combining TECDOS chains.

PI-/GAMMA drive principle

Versatile module for drive and idler application. Integrated roller bearings. Drive shaft free of additional forces. No shaft required when used as idler module. Integrated chain guide and stripper.

Advantages:

- Versatile application possibilities as drive unit module & redirection module
- Integrated bearing
- Chain guide and stripper integrated
- Drive shaft without any additional forces
- Shaft not required when utilising redirection module



TIP

We can also provide special paintwork according to maritime specifications on request.

Multiple chain strand systems PI / Gamma

Modular design for highest-possible flexibility when selecting electrical, hydraulic or pneumatic motors.



System applications for TECDOS PI/GAMMA:



Vertical PI drive

Vertical PI drive unit as double arrangement with two parallel operating drive units.

Also possible in 2, 3 and 4 fold arrangements with drive units depending on the application.

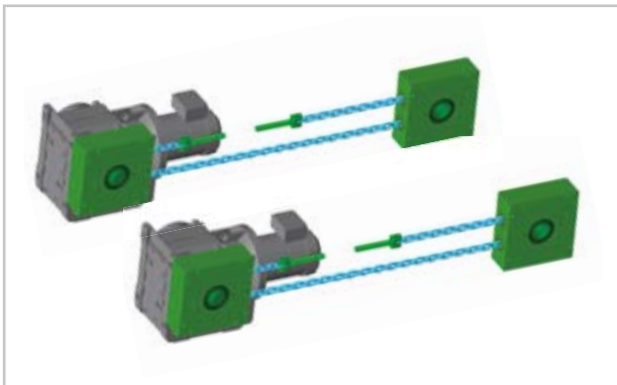

Horizontal PI drive

Horizontal drive unit as double arrangement with two parallel operating PI drive units.

Also possible in 3 and 4 fold arrangements with drive units depending on the application.

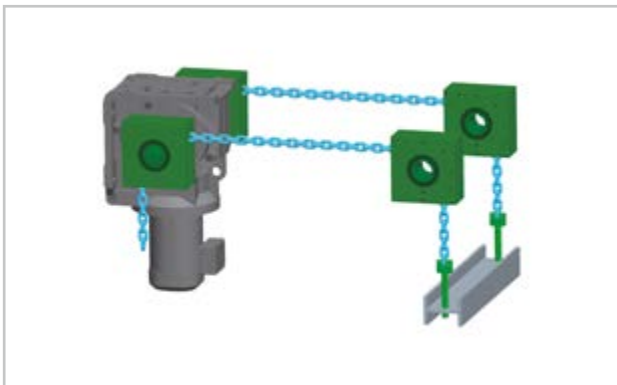

Double strand with GAMMA drive

Vertical GAMMA drive unit as double arrangement with one drive units.

Also possible in 3 and 4 fold arrangements with drive units depending on the application.

TECDOS ADVANTAGE:

ALL FROM ONE MANUFACTURE

3. TECDOS® Systems

3.3 OMEGA DRIVE | Innovative drive system



OMEGA DRIVE is the ideal drive solution for linear or rotating movements. In order to process a running crane trolley on a carrier, ship cranes on a rail or for skid application. The OMEGA DRIVE is superior to comparable rack and pinion and sprocket wheel solutions.

In comparison it is less sensitive to dirt, sand, ice, etc., is easier to mount and tolerates deviations of alignment. The modular concept allows the drive through electric, hydraulic or pneumatic motors, at order point electric motor can be supplied.

OMEGA DRIVE principle

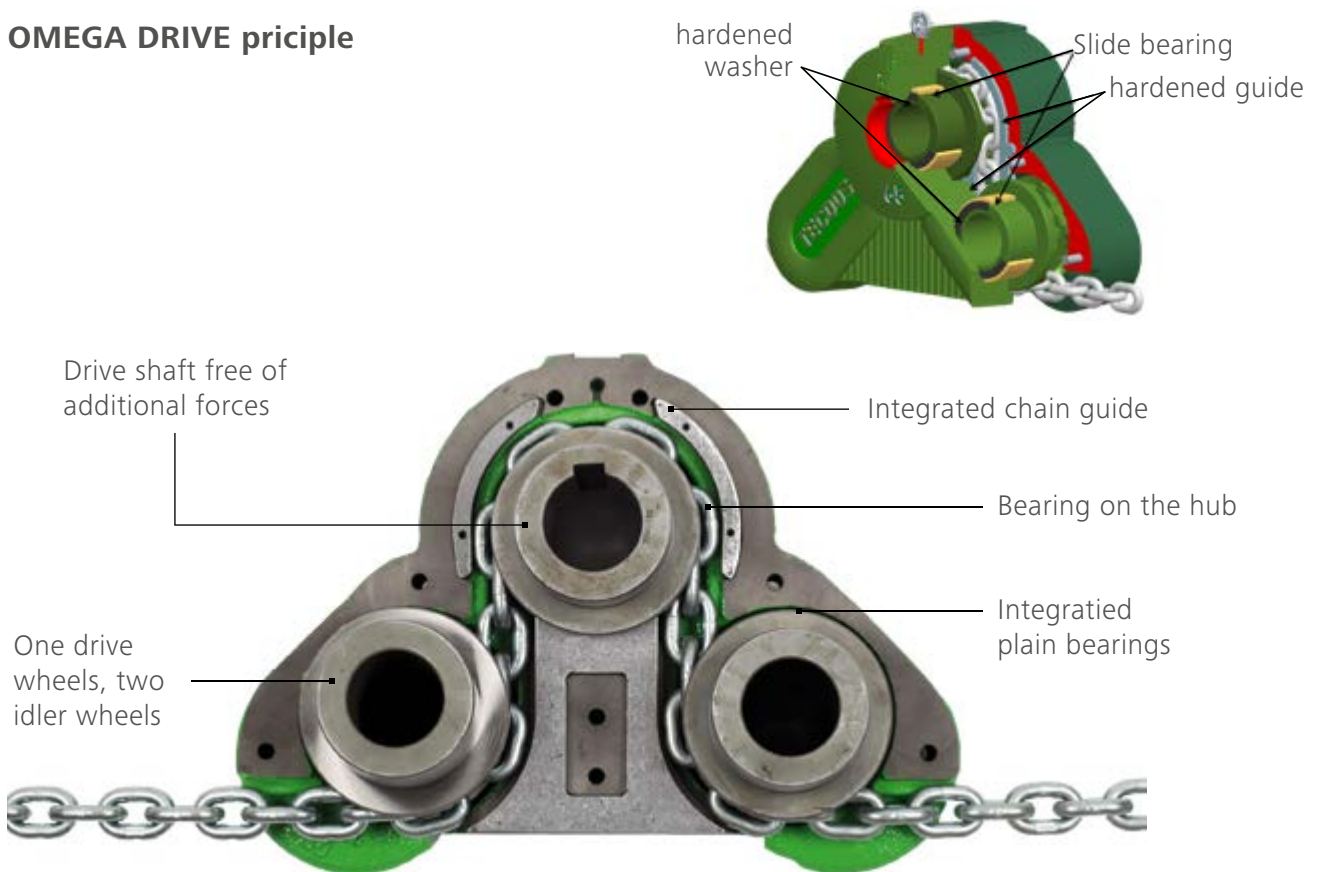

OMEGA DRIVE complete system

OMEGA DRIVE offers quiet and reliable performance long after that of a rack and pinion drive.

OMEGA DRIVE is resistant to ice, dirt, rain and aggressive environments. This drive concept has proven itself in many applications worldwide.

OMEGA DRIVE applications

RUD OMEGA DRIVE is the solution: for moving ship cranes, tracking solar panels to the sun, or simply traversing a machine.

Supplementary parts for flangemounting of motors available on request.

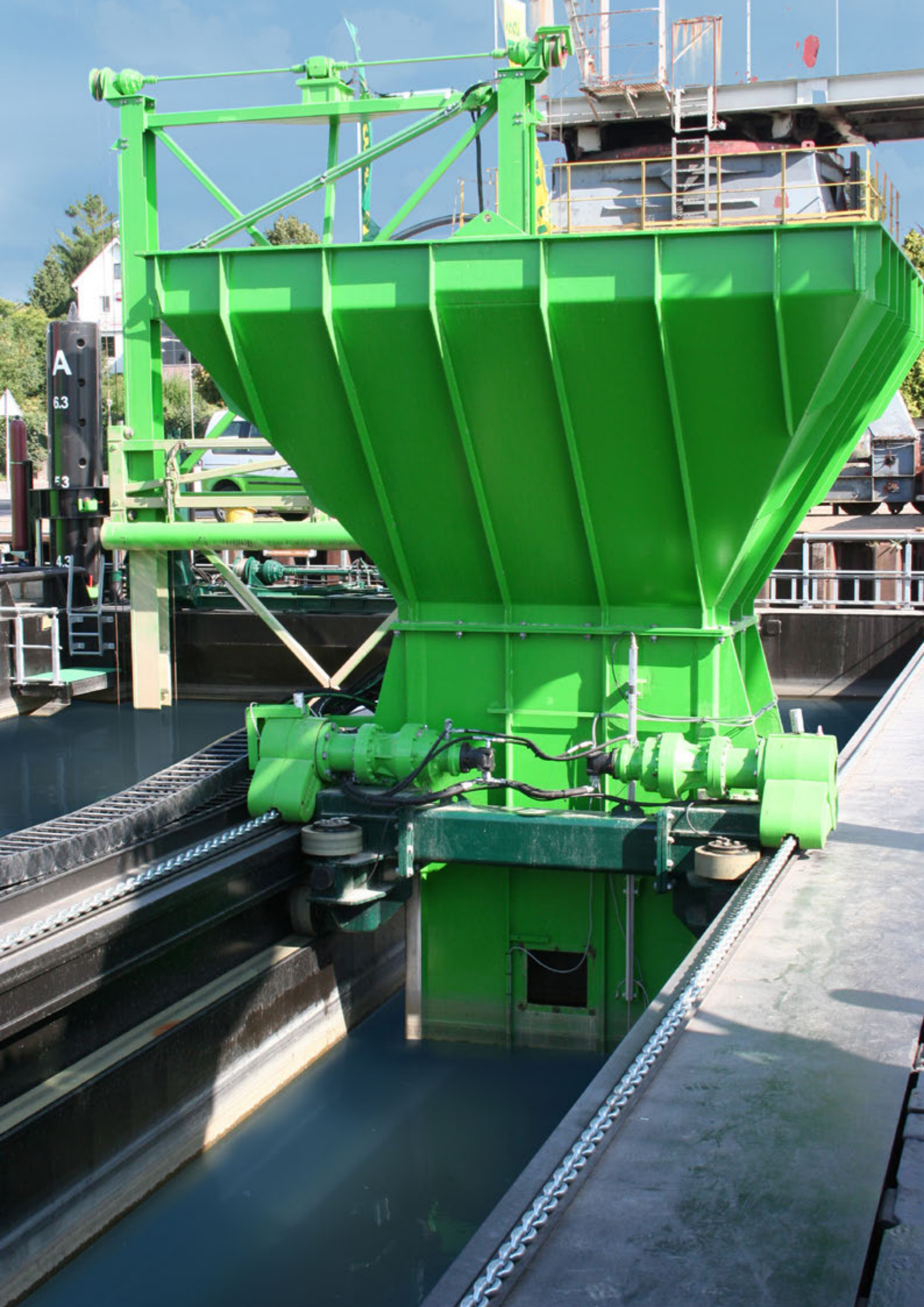

3. TECDOS® Systems

Complete system | Versatile drive systems for linear and curved motion

1. Linear travel, fixed drive and moving chain / equipment

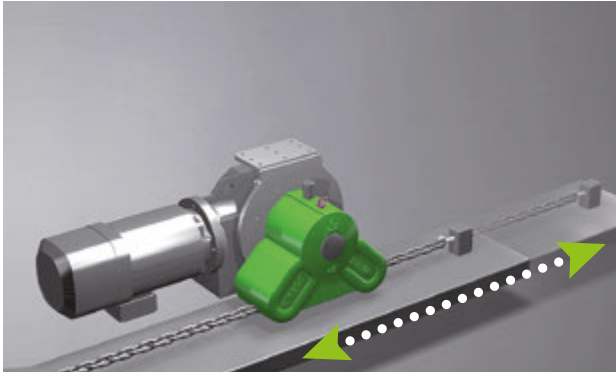

2. Moving drive and fixed chain / equipment

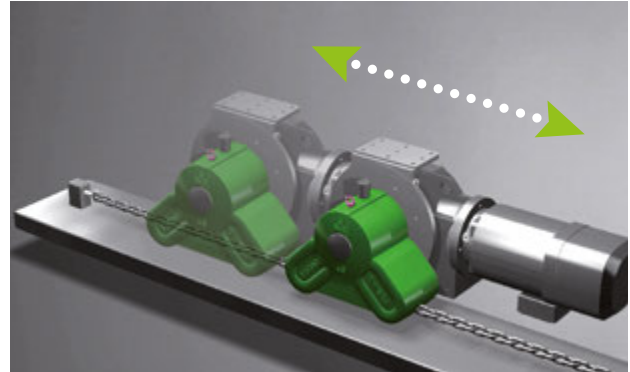

3. Fixed drive and rotating chain / equipment

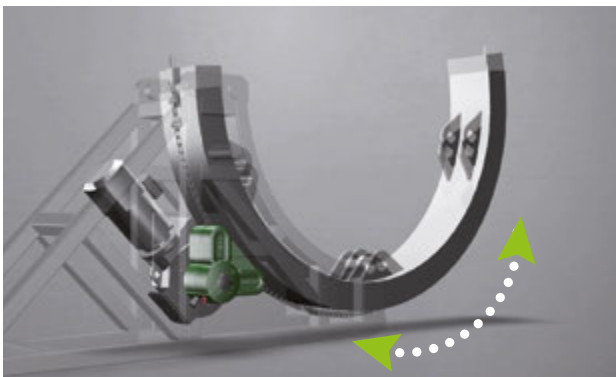

4. Fixed chain, drive / equipment moving along curved path

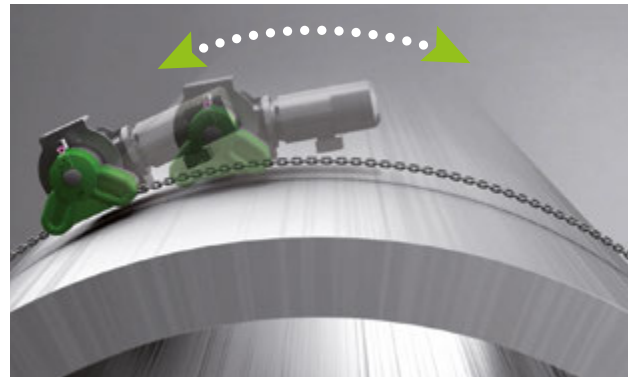

Your perfect companion for various systems:

- Moving harbour and ship cranes
- Aligning and adjusting ship loading and unloading
- Opening and closing sliding doors in the holds
- Rotating and lifting platforms
- Propulsion for ferries on rivers and lakes
- Moving wagons for unloading
- Extending telescopic booms for ship loaders and cranes
- Moving sea posts (spud pole)
- Traversing Skidding Systems

OMEGA DRIVE

Approval by major maritime classification societies possible

Spezifikationen:

- Operating force 6 – 260 kN
- Mobile or fixed drive
- OMEGA DRIVE - Weight 20 – 2.163 kg
- Chain speed 1 - 6 m/minute with full load, up to 12 m/minute with part load



Technical data

→ p. 45

3.4 OMEGA DRIVE modular system | for maximum flexibility in the choice of an electric, hydraulic or pneumatic motor

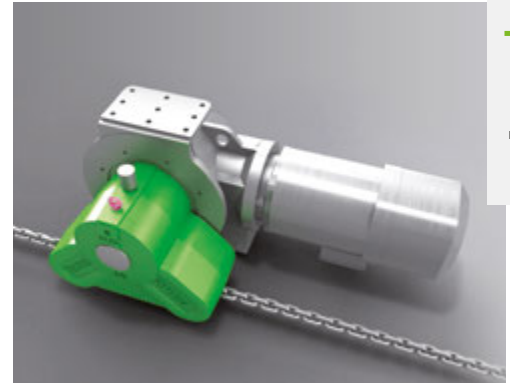
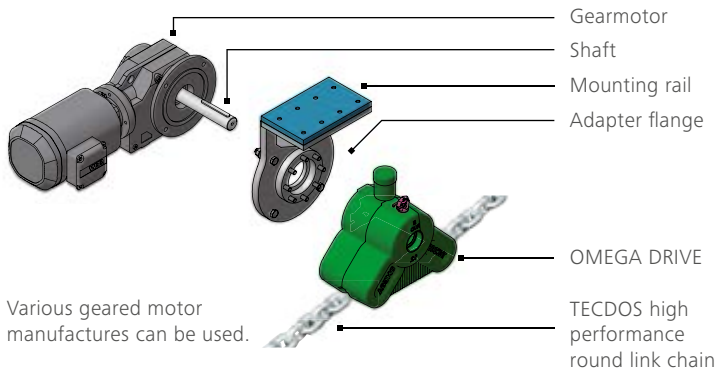

OMEGA DRIVE is available in 7 various operational forces:

Product advantages:

- less sensitive to dirt, sand, ice
- easy to mount
- tolerates alignment and measurement deviations, such as temperature elongation
- does not generate reaction forces
- can be used in all directions
- weather and corrosion resistant

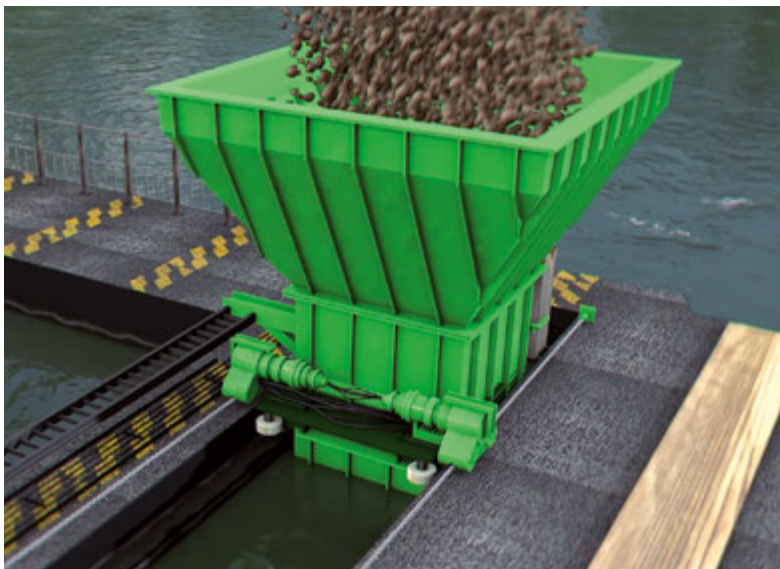
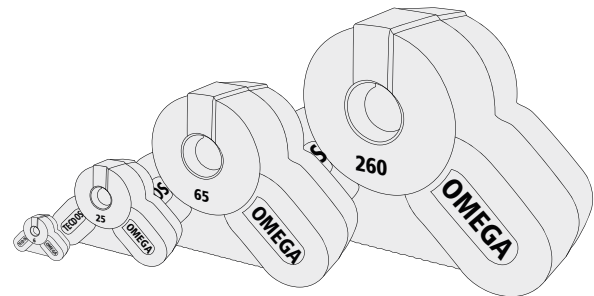

OMEGA DRIVE Hotline:
+49 (0) 7361 504-1457



More information:
www.youtube.com/user/RUDKetten



3. TECDOS® Systems

3.5 TOOL MOVER handle heavy objects safely and easily



Problems with conventional rotating and turning equipment: Huge operator risk, Potential damage to costly tools and damage to hoist brakes and ropes.

RUD Solution: TOOL MOVER turned heavy, sensitive tools & machine components.

The TOOL MOVER can be used anywhere in the plant, since it is not anchored to the floor and is very compact**. The TOOL MOVER can be moved with a hoist (lifting points) or lift truck (fork insertion points). Since the TOOL MOVER table has a very low supporting surface, the open tool can be cleaned while on the table itself. The TOOL MOVER is equipped with PU* plates to protect the tool. The TOOL MOVER can handle tools and objects weighing up to 64 tons. A siren to indicate that the table is operating is standard equipment.

*only THS 10 **no standard

„The highest priority in the purchase of RUD TOOL MOVERS was the safety of our employees. Furthermore, damage to the items to be turned is effectively excluded. In addition, we save considerable working hours. With the TOOL MOVER, only one employee turns the tool in half the time, which often took two or three men when turning the crane. In addition, the hall floors and lifting gear are protected.“



DECKERFORM

www.deckerform.de

TOOL MOVER with optional attachments and safety equipment (no standard):

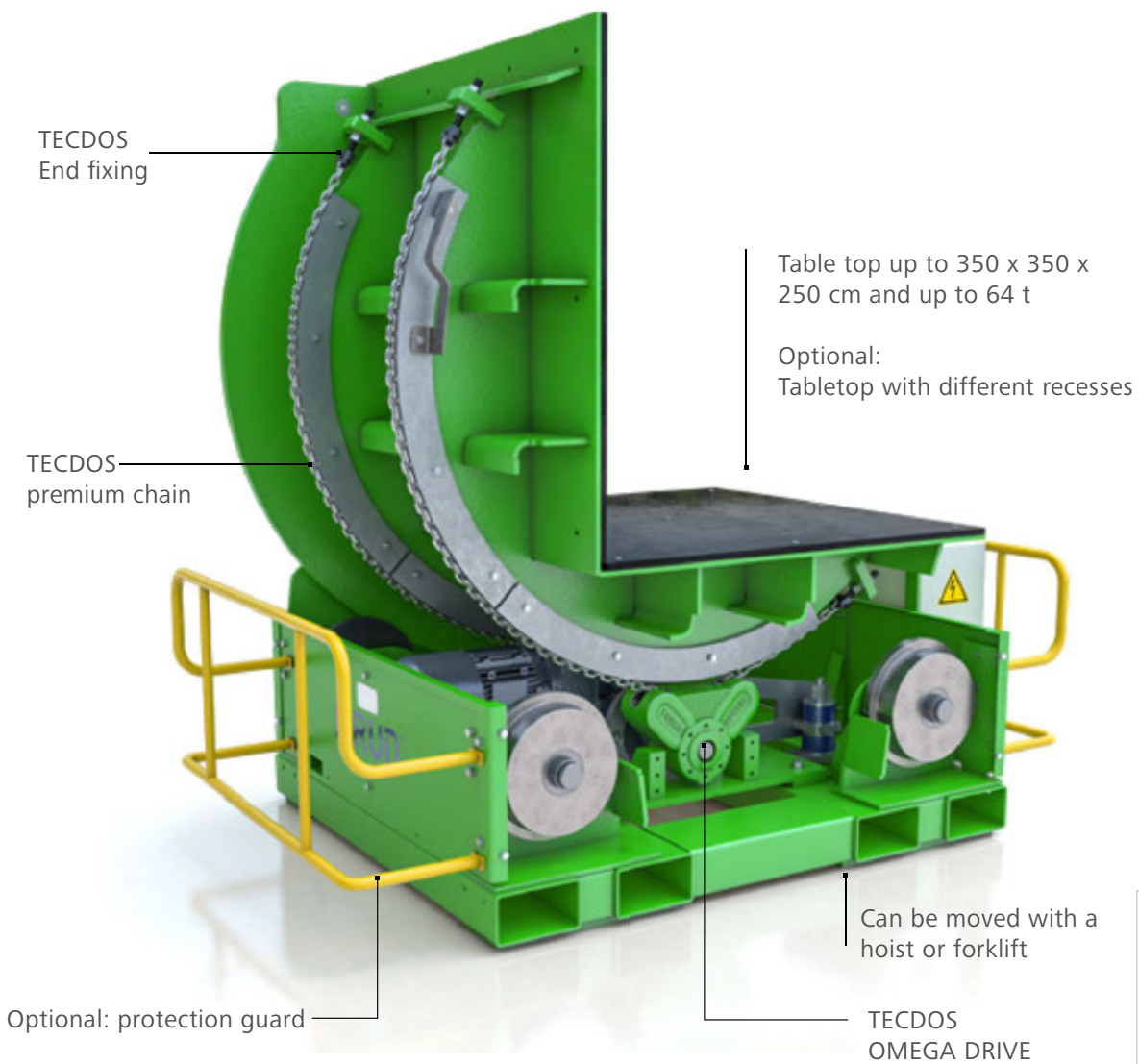

Technical data
→ p. 43

Detailed information:

We would be pleased to provide you with the separate TOOL MOVER brochure.



Contact

TOOL MOVER Hotline:
+49 (0) 7361 504-1442

More Information:

www.youtube.com/user/RUD-Ketten

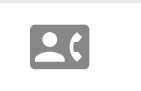

Configure your TOOL MOVER quickly and easily!

More information:
www.rud.com/en/products/conveyor-drive-systems

4. Spare parts & Components

**A WELL-ROUNDED
RESULT.**





ROBUST DURABLE SAFE

For all TECDOS drive solutions always the optimum chain selection for pivoting, lifting, handling, telescoping and rotating.

4. TECDOS® Spare parts & components

4.1 TECDOS® Round link chain | Material and application benefits

The core component of each TECDOS system application is a highly wear-resistant RUD round link chain for maximum service life – even with wear-resistant media. Extremely dynamic strength therefore ensures maximum operational safety.

TECDOS is always the best solution:

- when high forces have to be transmitted within limited space
- when three-dimensional mobility is required
- under severe environmental conditions
- when exposed to weather
- in offshore, underwater and harbour applications
- when the means of traction has to have optimized storage capacity

TIP

Lubrication enables you to achieve up to 10-15 fold service life.

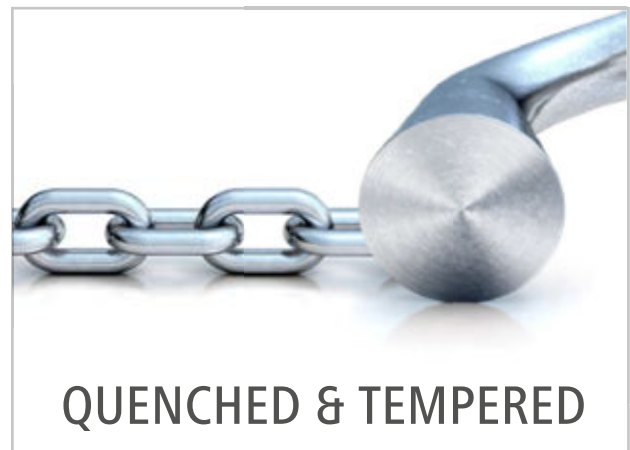

- when frequent use is required

- when infrequent use is required

Corrosion protection for TECDOS high performance chain

Surface	Short description of surface coating	New condition	After 100 hours salt-spray test
Electrolytic galvanised *topcoat silver	electrolytic metal deposition (6-10 µm)		

Technical data

→ p. 40

Designed for all environments

High robustness



3D-mobility



Small deflection radius



Easy storable



Trouble-free maintenance



Simply end fixing



Reliable with low actuation



Reliable with more frequent actuation



4. TECDOS® Spare parts & components

4.2 TECDOS® pocket wheels

Surface-hardened TECDOS pocket wheels are optimally designed to work with TECDOS chain and guarantee long life and silent running.

Features:

1. All TECDOS chain wheels are made of low-alloy steel, completely machined and surface-hardened
2. Chain wheels available for loads from 6 kN up to 260 kN
3. Geometry of the pockets is perfectly coordinated to the TECDDOS round steel chain
4. The bore and hub designs can be designed as customer-specific requirements (toothing possible with specification from DIN standard)
5. Rust resistant and acid resistant drive and redirection wheels available on request

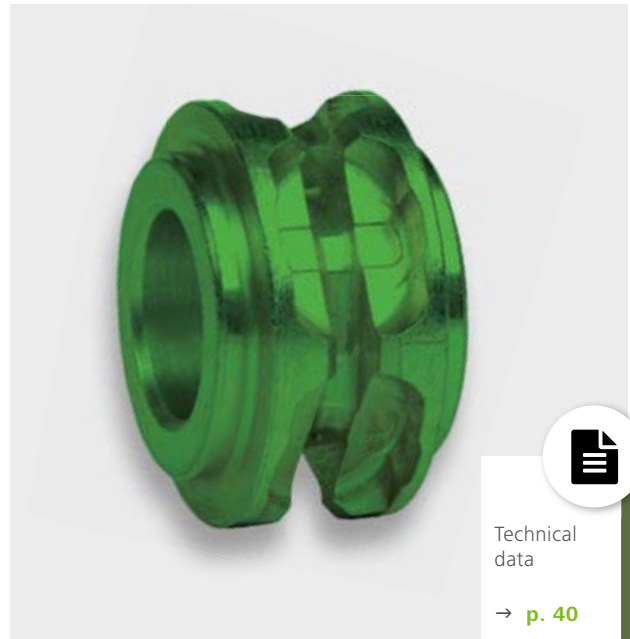

TECDOS® chain wheels for drive units and redirection can be manufactured for single and multiple chain strand configurations. Available on request for all chain sizes from TEC 6 to TEC 260 for loads from 6 up to 260 kN.



TIP

All TECDOS components can be delivered as rust resistant and acid resistant.

4.3 TECDOS® Chain guide

Chain guides are used under severe environmental conditions, when one chain strand is not loaded, when the chain is prone to jumping off the sprocket wheel, to ensure smooth running of the chain over the sprocket wheel.



Differences of the two executions:

- Machined chain guide heat treated for optimal wear resistance
- Chain guide laser cut, without heat treatment
- radially divided for simplified assembly

The selection of the chain guide depends on the application and the operation environment.

Please contact your RUD specialist for further information.



TECDOS® Application

1. Pi pocket wheel block
2. PowerPoint fixing point
3. Chain guide redirection unguided
4. Round link chain medium/premium
5. End fixing



4. TECDOS® Spare parts & components

4.4 RUD lift limiter



The lift limiter prevents the chain from “passing through” i.e. it serves as a travel route limiter on the unloaded sides of the chain.

Features:

- Limits the lift of a TECDOS drive system and
- Prevents the chain from being pulled through by the PI/ GAMMA or chain guides units



Technical data → [p. 41](#)

4.5 RUD chain connector



TECDOS chains and connectors form a reliable system. Both components perfectly fit in combination with the OMEGA DRIVE or chain wheels.

Features:

- Connects the chain to an endless chain loop
- Attention: Operating forces are limited to maximum power of the chain connector



Technical data → [p. 42](#)

4.6 TECDOS® End fixing



Axial adjustable end fixing for linking the chain and load-supporting structures

Features:

TECDOS End fixing:

- Transfers 100 % of the TECDOS chain operating forces
- axially adjustable



Technical data → [p. 42](#)

4.7 RUD foolproof high dynamic shackle

High tensile version with an integrated safety thread in the shackle bracket.

Features:

- Smooth bolt support in the shackle on both sides.
The bolt is turnable
- No bending strength in the thread (only a securing function)
- Optimal adaptation - max. mouth width with the smallest shackle bolt
- Owing to the turned clevis connection, it is extensively resistant to bending
- Long term securing by driving in the pre-assembled tensioning sleeve
- Special thread, thus distinctive in comparison to other shackle bolts
- Pre-assembled connecting bolt and tensioning sleeve



Technical data → [p. 42](#)

4.8 RUD PowerPoint fixing point

RUD fixing points are easy to rotate and always the right connection

Features:

- Rotating 360°, pivoting 230°
- Universal, unmistakable VIP connection for chain, hook and eye
- Double ball bearing for turning/rotating operations



Technical data → [p. 43](#)

4.9 RUD Cobra fork head hook

The Cobra hook with a ring connection and of course all the advantages of a RUD - clevis hook.

Features:

- Very robust design without a protruding hook tip
- The forged safety latch engages in the tip of the hook and is thus protected against lateral bending
- With a triple coiled corrosion protected double leg spring
- Thickened tip of the hook to prevent misuse
- Wear marks on both sides
- Gauge marks for measuring the width of the hook opening

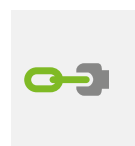
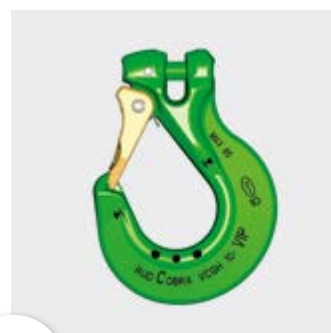

Technical data → [p. 43](#)

5. Information & Services

**SO EVERYTHING
MOVES, WHICH
HELPS YOU TO
MOVE FORWARD.**

A close-up photograph of two hands shaking in a firm grip, symbolizing agreement or partnership. The hands are positioned in the lower half of the frame, with the fingers interlaced. The background is a soft, out-of-focus green and yellow gradient, matching the overall color scheme of the page.



COMPETENT RELIABLE REACHABLE

Our expert knowledge enables us to reliably support you during and after the optimisation of your processes. In order to fulfil this demand, we can provide you with extensive offers and services.

5. TECDOS® Information

5.1 Technical charts

TECDOS® round link chain

Medium

quenched and tempered chain HV approx. 360



Premium

case hardened chain HV 580 – 600



Sizes

round link chain is available in 7 sizes

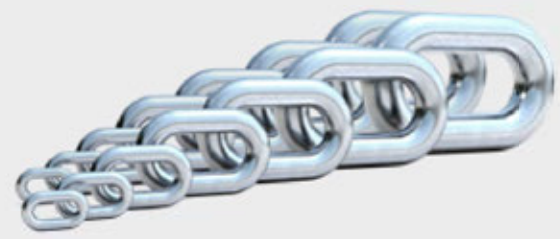

TEC 6 - TEC 260 kN

Chain	Working load [kN]	Weight approx. [kg/m]	Breaking force [kN]	Medium (part no.)	Premium (part no.)
TEC 6	6	0,59	34,0	7905137	7905146
TEC 12	12 ²	1,13	65,1	7905102	7905113
TEC 25	25 ²	2,24	126,0	7905093	7905068
TEC 43	43 ²	3,80	212,3	7905057	7905040
TEC 65	65 ²	5,70	322,0	7904959	7905020
TEC 140 ¹	140 ²	12,30	694,0	7904948	7905015 ³
TEC 260 ¹	260 ²	22,6	1315,0	7904947	-

¹ topcoat silver ² When using with TECDOS chain connectors the operational force of the chain has to be adapted according to the specification of the connectors. ³ max. 44 m length per strand

Product information → p. 32

TECDOS® chain wheels

chain size	No. of pockets*	Pitch circle diameter ø (mm)	Hub length B [mm]	Bore ø D [mm]	Outer ø F [mm]	No. of Keyways DIN 6885 P9 [mm]	Weight [kg]	Part no.
TEC 6	6	58,4	45	30 H7	63,5	1	0.5	7905327
TEC 12	6	82,3	70	40 H7	89,5	1	1.5	7905328
TEC 25	6	108,0	100	50 H7	118,0	1	3.8	7905329
TEC 43	6	139,2	120	70 H7	152,0	1	7.1	7905330
TEC 65	6	174,5	150	90 H7	190,5	1	13.0	7905331
TEC 140	6	256,2	200	130 H7	279,5	2**	42.6	7905332
TEC 260	6	347,8	250	180 H7	379,5	2**	101.0	7905333

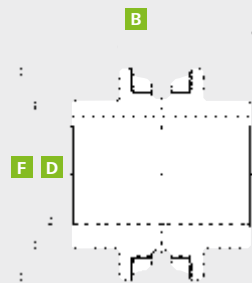

*) Standard 6 pockets other sizes on request
 **) Keyways at 120° offset

Product information → p. 34

TECDOS® chain guide

Milled chain guide, radially divided

Chain	Pockets	Weight [kg]	L1	L2	L3	L4	Part no.
TEC 6	6	1.6	114	118	25	37	7906322
TEC 12	6	4.2	145	161	35	50	7906186
TEC 25	6	9.6	190	209	50	60	7902719
TEC 43	6	18.3	239	263	65	80	7902294
TEC 65	6	31.7	284	322	80	100	7902289
TEC 140	6	97.0	404	463	118	142	7902320
TEC 260	6	206.6	525	621	193	150	7902038

Product information → [p. 35](#)

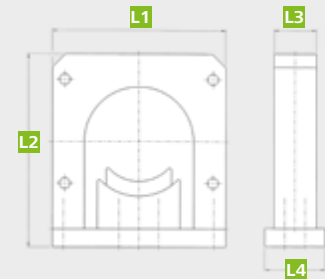

Laser cut chain guide, radially divided

Chain	Pockets	Weight [kg]	L1	L2	L3	L4	L5	Part no.
TEC 6	6	2.1	164	120	22	30,4	44	8504484
TEC 12	6	3.5	195	162	24	32,4	49	8504465
TEC 25	6	8.3	248	210	36	46,	65,3	8503920
TEC 43	6	–	–	–	–	–	–	on request
TEC 65	6	–	–	–	–	–	–	on request

Product information → [p. 35](#)

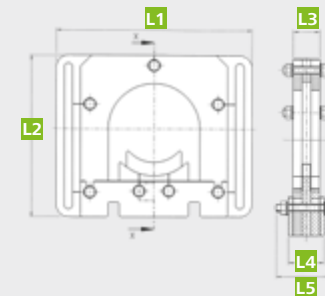

RUD lift limiter

Chain	Weight [kg]	Part no.
TEC 6	0.14	7906314
TEC 12	0.5	7907126
TEC 25	0.4	7906460
TEC 43	1.7	7906401
TEC 65	4.0	7906315
TEC 140	8.0	7906316
TEC 260	–	on request

Product information → [p. 36](#)



Discover now **RUD TECDOS chains drivers and components** on traceparts. RUD product-download simplifies design!
[Click here](#) or search www.traceparts.com/en for **TECDOS**.

5. TECDOS® Information

5.1 Technical charts

RUD chain connector

Part no.	Chain size	Working load [kN]	Load cycles to failure	Max. allowed chain speed	Weight [kg]	Surface
7908978	TEC 12	9	20.000	8 m/min	0.035	painted
7908986	TEC 25	18	20.000	8 m/min	0.095	painted
7908995	TEC 43	30	20.000	8 m/min	0.2	painted
7908990	TEC 65	45	20.000	8 m/min	0.38	painted
7906522	TEC140	100	20.000	8 m/min	1.15	painted

Product information → [p. 36](#)



TECDOS® end fixing

Designation	Chain	Working load [kN]	A [mm]	D [mm]	F [mm]	Weight [kg]	Part no.
HEBG-M12	TEC6	6	103,0	79,0	32,0	0.145	7996526
HEBG-M16	TEC12	12	139,0	107,0	42,0	0.4	7993561
HEBG-M24	TEC25	25	198,0	155,0	56,0	1.0	7997341
HEBG-M30	TEC43	43	249,0	195,0	70,0	2.0	7997329
HEBG-M36	TEC65	65	303,0	237,0	82,0	3.4	7997326
HEBG-M42	TEC140	140	388,0	293,0	116,0	7.6	7997385
HEBG-M48	TEC260	260	482,0	353,0	160,0	16.5	7997420

Product information → [p. 36](#)

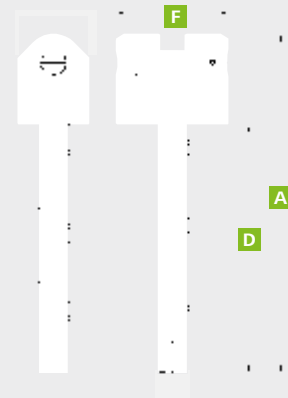

RUD foolproof high dynamic shackle

Attention, this component has been modified for TECDOS applications.

Standard components from the RUD VIP Family are suitable for TECDOS drive chains.

Designation	Chain	A [mm]	B [mm]	C [mm]	D [mm]	E [mm]	G [mm]	H [mm]	T [mm]	Weight [kg/ Stk.]	Part no.
Shackles - VV-GSCH 6	TEC 6	17	8	22	10	21	40	28	36	0.13	7909779
Shackles - VV-GSCH 8	TEC 12	21	10	26	12	32	48	39	48	0.27	7909780
Shackles - VV-GSCH 10	TEC 25	27	13	34	16	35	62	44	60	0.6	7909781
Shackles - VV-GSCH 13	TEC 43	33	17	42	20	41	81	59	78	1.3	7909782
Shackles - VV-GSCH 16	TEC 65	38	21	49	24	49	95	69	96	2.25	7909783
Shackles - VV-GSCH 22	TEC 140	53	30	76	36	72	130	95	132	6.43	7909784

Product information → [p. 37](#)

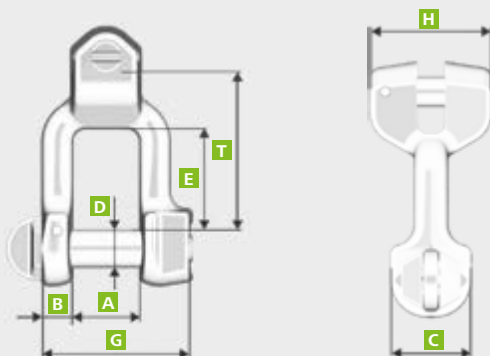

RUD PowerPoint fixing point

Attention, this component has been modified for TECDOS applications.

Standard components from the RUD VIP Family are not suitable for TECDOS drive chains.

Designation	Chain	D [mm] corner dimension	E [mm] wrench width	F [mm]	M [mm]	Md [mm]	T [mm]	Weight [kg/Stk.]	Part no.
PP-VIP M16	TEC 6	46	41	25	16	17.5	50	0.42	7909768
PP-VIP M20	TEC 12	61	55	30	20	22	61	0.94	7909769
PP-VIP M24	TEC 25	78	70	36	24	26	77	1.82	7909770
PP-VIP M30	TEC 43	95	85	45	30	33	93	3.47	7909771
PP-VIP M36	TEC 65	100	90	54	36	39	102	4.69	7909772

Product information → [p. 37](#)



RUD Cobra fork head hook

Attention, this component has been modified for TECDOS applications.

Standard components from the RUD VIP Family are not suitable for TECDOS drive chains.

Designation	Chain	A [mm]	B [mm]	C [mm]	D [mm]	F [mm]	F _{max} [mm]	G [mm]	T [mm]	Weight [kg/Stk.]	Part no.
Hook VCGH 6	TEC 6	38	22	16	20	25	45	72	76	0.4	7909773
Hook VCGH 8	TEC 12	50	28	20	28	30	52	95	97	0.8	7909774
Hook VCGH 10	TEC 25	60	36	26	36	35	65	118	108	1.5	7909775
Hook VCGH 13	TEC 43	76	46	30	37	40	73	135	126	2.8	7909776
Hook VCGH 16	TEC 65	83	56	36	49	48	87	161	152	4.7	7909777
Hook VCGH 22	TEC 140	117	78	50	74	63	114	223	198	11.9	7909778

Product information → [p. 37](#)

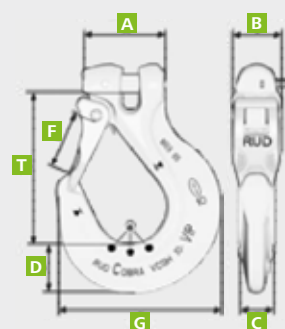

TECDOS TOOL MOVER

Typ	Table surface [cm]			Maximum load capacity	Own weight approx [kg]
	L	H	B		
THS 10	100	100	100	10.000	1.550
THS 16	160	160	160	16.000	4.400
THS 20	160	160	160	20.000	4.450
THS 25	250	250	250	25.000	11.350
THS 32	250	250	250	32.000	11.400
THS 64	350	350	250	64.000	22.000

Product information → [p. 28](#)

5. TECDOS® Information

5.1 Technical charts

TECDOS® PI KFGA-L 180° without flange mounting

Chain	No. of Pockets	Pitch circle diameter [mm]	L1 [mm]	L2 [mm]	L3 [mm]	ø D1 [mm]	Weight [kg]	Part no.
TEC 6	6	58,4	132	134	53	30	6.3	7907923
TEC 12	6	82,3	170	168	76	40	14.5	7908019
TEC 25	6	108,0	218	212	106	50	32.0	7908033
TEC 43	6	139,2	268	265	126	70	58.0	7908056
TEC 65	6	174,5	314	325	156	90	99.0	7907782
TEC 140	6	256,2	426	463	210	130	251.0	7910449
TEC 260	6	347,8	550	620	252	180	521,0	7909792

Product information → [p. 22](#)

TECDOS PI-/Gamma drives can be manufactured appropriate to all chain sizes. Other sizes on request.

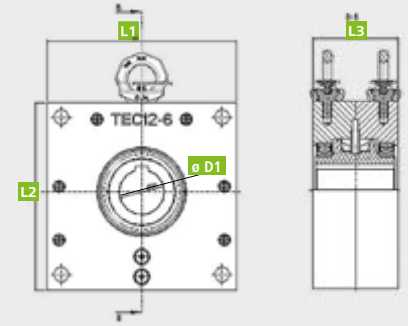

KFGA-LFL 180° with flange mounting

Chain	No. of Pockets	Pitch circle diameter [mm]	L1 [mm]	L2 [mm]	L3 [mm]	ø D1 [mm]	ø D2 [mm]	Weight [kg]	Part no.
TEC6	6	58,4	170	170	57	30	110,5	11.5	7905451
TEC12	6	82,3	260	260	80	40	180,5	37.3	7905430
TEC25	6	108,0	310	310	110,5	50	230,5	74.6	7905520
TEC43	6	139,2	360	360	131,5	70	250,5	111.0	7905745
TEC65	6	174,5	460	460	161,5	90	350,5	224.0	7906750
TEC140	6	256,2	426	463	216	130	340	254.0	7910452
TEC260	6	347,8	550	620	258	180	400	530.0	7908714

Product information → [p. 22](#)

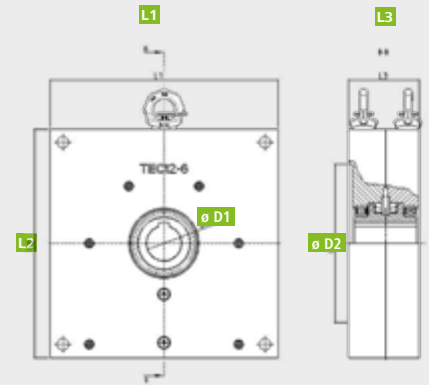

TECDOS® GAMMA KFGA-L 90 - 180° without flange mounting

Chain	No. of Pockets	Pitch circle diameter [mm]	L1 [mm]	L2 [mm]	L3 [mm]	ø D1 [mm]	Weight [kg]	Part no.
TEC6	6	58,4	161	161	53	30	8.8	7908072
TEC12	6	82,3	173	173	76	40	16.0	7908087
TEC25	6	108,0	223	223	106	50	33.0	7908096
TEC43	6	139,2	281	281	126	70	60.0	7908108
TEC65	6	174,5	341	341	156	90	105.0	7908113
TEC140	6	256,2	482	482	210	130	277.0	7910455
TEC260	6	347,8	640	640	252	180	573,0	7910182

Product information → [p. 22](#)

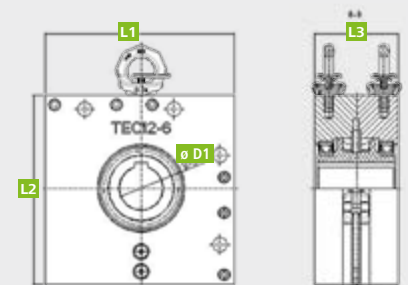

KFGA-LFL 90 - 180° with flange mounting

Chain	No. of Pockets	Pitch circle diameter [mm]	L1 [mm]	L2 [mm]	L3 [mm]	ø D1 [mm]	ø D2 [mm]	Weight [kg]	Part no.
TEC6	6	58,4	170	170	57	30	110,5	11.0	7908786
TEC12	6	82,3	260	260	80	40	180,5	38.0	7908457
TEC25	6	108,0	310	310	110,5	50	230,5	70.0	7908459
TEC43	6	139,2	360	360	131,5	70	250,5	102.0	7909612
TEC65	6	174,5	460	460	161,5	90	350,5	217.0	7908681
TEC140	6	256,2	482	482	216	130	340	291.0	7910457

Product information → [p. 22](#)

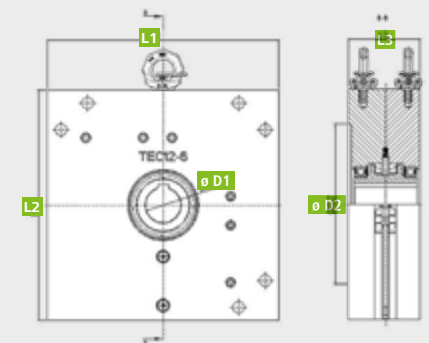

TECDOS® GAMMA KFGA-L +/- 45° without flange mounting

Chain	No. of Pockets	Pitch circle diameter [mm]	L1 [mm]	L2 [mm]	L3 [mm]	ø D1 [mm]	Weight [kg]	Part no.
TEC 6	-	-	-	-	-	-	-	-
TEC 12	-	-	-	-	-	-	-	-
TEC 25	-	-	-	-	-	-	-	-
TEC 43	6	139,2	268	281	126	70	57	7910343
TEC 65	6	174,5	320	341	156	90	101	7910347
TEC 140	6	256,2	430	482	210	130	254	7910351
TEC 260	6	347,8	550	640	252	180	493	7910355

Product information → p. 22

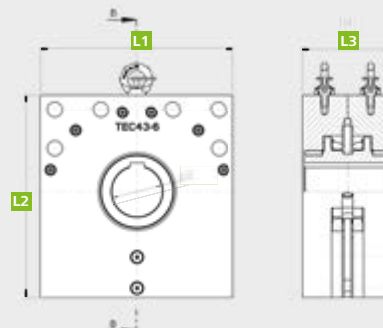

OMEGA DRIVE

Designation	Height (h) [mm]	Width (b) [mm]	Depth (t) [mm]	weight [kg]	Diameter (d) shaft mounting [mm]	Number of keyways DIN 6895 [mm] P9	Part no.
OMEGA 6	157	219	147	20	25 H7	1	7907541
OMEGA 12	219	305	130	30	40 H7	1	7907542
OMEGA 25	290	405	188	76	50 H7	1	7907543
OMEGA 43	372	520	219	140	70 H7	1	7907544
OMEGA 65	468	649	296	297	90 H7	1	7907545
OMEGA 140	685	953	444	991	130 H7	2 (120°)	7905364
OMEGA 260	920	1293	547	2163	180 H7	2 (120°)	7905371

Product information → p. 24

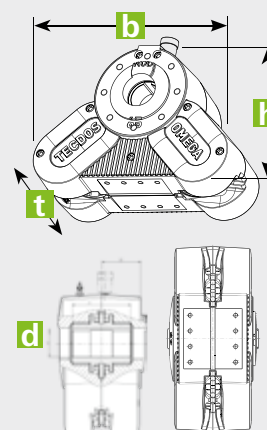

Modular system

Designation	Working load [kN]	Speed [m/min]	Gearmotor z.B.: SEW	Adapter flange	Shaft	Mounting Rail
OMEGA 6	6	6	KHF 47 DRN80M4	X	X	X
		8	KHF 47 DRN90L4			
		10				
		12				
OMEGA 12	12	6	KHF 67 DRN90L4	X	X	X
		8	KHF 67 DRN100M4			
		10				
		12				
OMEGA 25	25	6	KHF 87 DRN100LC4	X	X	X
		8	KHF 87 DRN132S4			
		10				
		12				
OMEGA 43	43	6	KHF 97 DRN132M4	X	X	X
		8	KHF 97 DRN132MC4			
		10				
		12				
OMEGA 65	65	2	KHF 107 R77DRN100M4	X	X	X
		4	KHF 107 R77DRN132M4			
		6	KHF 107 DRN132MC4			
		8	KHF 107 DRN160M4			
		10	KHF 107 DRN160MC4			
OMEGA 140	140	2	PHF002 KF77 DRN132M4	X	X	X
		4	PHF002 KF77 DRN160MC4			
		6	PHF002 KF87 DRN180M4			
		8	PHF002 KF87 DRN180LC4			
		10	X4KH150/HU/F			
OMEGA 260	260	1	PHF032 KF97 DRN132M4	X	X	X
		2	PHF032 KF97 DRN160M4			
		3	PHF032 KF97 DRN180M4			
		4	PHF032 KF97 DRN180L4			

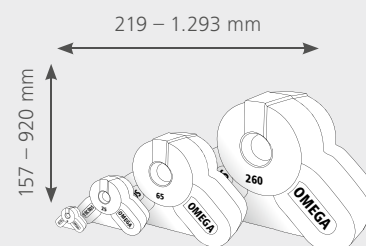

OMEGA DRIVES is available in 7 operational forces.

RUD-Service



TECDOS high performance chains are extremely robust and require very little maintenance due to their simple construction. The following points are our support for a improved operating safety:



The RUD service concept



Measure, document, maintain

- Consultation and recommendation for spare parts
- Maintenance
- Replacement of competitors products with RUD products
- On-site consultation
- Measuring and testing
- On-site installation
- Fault elimination
- Inspection
- Retrofitting



The RUD engineering concept



Calculation, Construction & Consultation

- Product development and further development
- Dimensioning of the best components for your individual requirement
- Technical consultation, if needed on-site
- Synchronisation of all components to your individual requirements
- On request provision of CAD files
- Problem solving in case of difficult cases of operation



Discover now **RUD TECDOS chains drivers and components** on traceparts. RUD product-download simplifies design! **Click here** or search www.traceparts.com/de for **TECDOS**.

Technical questionnaire

Drive Systems



RUD Ketten
 Rieger & Dietz GmbH & Co. KG
 Tel.: +49 (0) 7361 504-1457
 Fax: +49 (0) 7361 504-1373
 tecdos@rud.com
 www.rud-tecdos.com

Please copy and fax or send to:

tecdos@rud.com (Fax +49 7361 504-1523)

CONTACT DATA

Firm:*	Responsible:*
Street:*	E-Mail:
ZIP / City:*	Tel.:
Date:	Preferred delivery date: <small>* Pflichtfelder</small>

PROJECT

Task: lifting pulling other: _____
 Please also send a separate sheet for sketches

Maximum tensile strength on the chain [kN]: _____ weight [kg]: _____ Friction factor [μ]: _____
 Roller friction 0 wheel / material parameter _____ Sliding friction: Friction factor* _____

Max. speedup [m/s²] / max. detension [m/s²]: _____

Speed[m/min] from: _____ to: _____

Cycle operation?? yes no cycles per: _____

Duty and passive state per cycle:: _____

Total operating time daily [h]: _____ annually [h]: _____

Length of traverse path [mm]: _____

Number of load chain strands: _____

New project Conversion Retrofit (specify housing dimensions) _____

Drive pocket wheel - pitch circle diameter [mm]: _____

Drive shaft diameter [mm]: _____

Chain used before conversion, type and dimensions, max breaking load, operating time and reason for the break down:

Environmental influences: corrosive abrasively temperature others _____

Remarks: _____

Drive system: Direct drive Gearmotor Pneumatic motor Hydraulic motor Electric motor

Current situation: _____ Rotational speed: _____ Performance: _____ Type: _____ Protection cover IP: _____

Desired situations: _____



RUD Ketten
Rieger & Dietz GmbH u. Co. KG
Friedensinsel
73432 Aalen / Germany
Tel. +49 (0) 7361 504-1457
Fax +49 (0) 7361 504-1543
E-Mail: tecdos@rud.com · www.rud.com



Conveying and driving



Whether you're looking for a complete bucket elevator, chain conveyor or chain drive, our wide experience in bulk goods handling, including cement, fertiliser, aggregates among many others, makes RUD the one-stop shop for your application.



For power generation with coal and biomass, as well in the recycling sector, RUD is a leading technology supplier for components and complete solutions based on round link chains and the FORKY product line. Whether for material feeding, ash removal or cleaning scrapers, RUD CRATOS has the solution you're looking for.



RUD components are the first choice worldwide for leading hoisting equipment manufacturers. We also offer a wide range of round link chains for industrial applications of all kinds.



RUD Powerblock and Dominator shackles set the benchmark worldwide and their unbeatable reliability makes them number one choice for high performance mining operations.



The RUD TECDOS team is developing and manufacturing drive solutions for turning, lifting, moving, telescoping or shifting. In addition to the component program, complete solutions like the TOOL MOVER are also available as the TECDOS OMEGA, GAMMA and PI drives.